



Manual

Ampeltools

Version V 3.31

Contents

1.	<i>Installation</i>	14
1.1	System requirements	14
1.2	Software CD	14
1.3	Activate program	14
1.4	Select language	15
1.5	Controller support	16
1.6	Error report tool	17
2.	<i>Program settings</i>	18
2.1	General settings	18
2.1.1	Automatic query about over-programming	18
2.1.2	Automatic query about calculating vehicle lengths	18
2.1.3	Automatic query about determining circulation time	18
2.1.4	Advanced mode	19
2.1.4.1	Program plan	19
2.1.4.2	Save / send data	20
2.1.4.3	Check for non-hostile pedestrians	21
2.1.4.4	Check red-yellow / yellow time small intermediate time	21
2.1.5	Editor options	21
2.1.5.1	Fill automatically	21
2.1.5.2	Draw groups freely	21
2.1.5.3	Only show automatically for error	21
2.1.5.4	Default circulation time	21
2.1.6	Program error test options	22
2.1.6.1	Editors open automatically in case of error	22
2.2	Signal group defaults	22
2.2.1	Profile	22
2.2.1.1	Standard profile	22
2.2.1.2	Own profiles	23
2.3	Print settings	23
2.3.1	No. of groups on a page	24
2.3.2	Print options	24
2.3.3	Print all	24
2.3.4	Print settings	24
2.3.5	Matrix name	25
2.4	Data storage	26
2.4.1	Standard directory	26
2.4.2	Ampelsim files export directory	26
2.4.3	Eprom files directory	26
2.4.4	Directory local public transport module	26
2.4.5	CPU simulation / CPU protocol directory	26
2.4.6	Create directory	27
2.5	User data	28
2.6	Additional modules	29
2.6.1	CPU simulation	29
2.6.2	CPU protocol	29
2.6.3	Check signal safeguarding	29
2.6.4	Enable training	29
2.6.5	Deactivate program	29
2.7	CPU simulation / Emergency controller	30
2.7.1	Signal display background colour	30
2.7.2	Options	30
2.7.2.1	Key sound at virtual keyboard	30
2.7.2.2	Start deletes all errors	30

3.	<i>Operating instructions</i>	31
3.1	General	31
3.1.1	Select controller type	32
3.1.2	Check interim time automatically	33
3.1.3	Check intersection time plan automatically for faulty functions	34
3.1.4	Automatic program check	35
3.1.5	Error messages	36
3.1.6	Copy functions	36
3.1.7	Delete functions	36
3.1.8	OK button	36
3.1.9	Cancel button	36
3.1.10	User code	37
3.1.11	Keyword	37
3.1.12	Data transfer between PC and controller	38
3.1.13	Automatic copy function	38
3.1.14	Menu bar in editors	38
4.	<i>Main window</i>	39
4.1	Basic supply	39
4.1.1	Interim times	39
4.1.1.1	Calculate interim times with vehicle lengths	39
4.1.1.2	Calculate interim times without vehicle lengths	40
4.1.1.3	Enter interim times manually	40
4.1.2	Operating mode	40
4.1.2.1	Fixed time mode with VA	40
4.1.2.2	Phase transitions	40
4.1.3	Interfaces	41
4.1.3.1	Controller interface	41
4.1.3.2	Interface for CPU protocol	41
4.1.4	Controller type	41
4.1.5	General data	41
4.1.6	Released programs	41
4.2	Toolbox	42
4.2.1	New program	42
4.2.2	Load data	42
4.2.3	Save data	43
4.2.4	Save data as	43
4.2.5	Send data to controller	44
4.2.5.1	Overprogramming	46
4.2.6	Receive data from controller	47
4.2.7	Data transfer between PC, MPB 4xxx and 12 groups interface	47
4.2.7.1	Send data to interface	48
4.2.7.2	Receive data from interface	48
4.2.7.3	Send data to MPB 4xxx	48
4.2.7.4	Receive data from MPB 4xxx	48
4.2.7.5	Send data to hand box	48
4.2.7.6	Send data to interface MPB 44 M	48
4.2.7.7	Receive data from interface MPB 44 M	49
4.2.7.8	Send data to MPB 44 M	49
4.2.7.9	Receive data from MPB 44 M	49
4.2.8	Emergency controller EPB 12 / EPB 24 / EPB 48	49
4.2.9	Show outputs	49
4.2.9.1	Show current controller data	50
4.2.9.1.1	Test mode	51
4.2.9.2	Show current radio clock data	51
4.2.9.3	Change radio clock IP address	53
4.2.9.4	DHCP server	53
4.2.9.5	Reset radio clock	53
4.2.10	Switch monitoring	54
4.2.10.1	Switch monitoring functions permanently off	55
4.2.10.2	Clear error memory	55
4.2.10.3	Clear program change memory	56

4.2.11	CPU simulation	56
4.2.12	CPU protocol	56
4.2.13	Printing data from controller	56
4.2.14	Configuration local public transport module	56
4.3	Menu structure	57
4.3.1	Menu structure symbols	58
4.3.2	Program settings	58
4.3.3	Controller	59
4.3.4	Basic data	59
4.3.5	Interim times	59
4.3.6	Program editor	59
4.3.7	Special masks	59
4.3.8	Parameter lists	59
4.3.9	Number of signal heads	59
4.3.10	Signal safeguarding	59
4.3.11	Radio clock / Progressive signalling	59
4.3.12	Program switching points	59
4.3.13	System functions	59
4.3.14	CPU simulation	59
4.3.15	CPU protocol	60
4.3.16	Check signal safeguarding	60
4.4	Menu bar	60
4.4.1	File	60
4.4.1.1	New program	60
4.4.1.2	Load data	60
4.4.1.3	Save data	60
4.4.1.4	Save data as	60
4.4.1.5	Save Ampelsim data	61
4.4.1.6	Send data by email	62
4.4.1.7	End	62
4.4.2	Windows	62
4.4.3	Print	63
4.4.3.1	Print PC data	63
4.4.3.1.1	Print basic data	64
4.4.3.1.2	Print program data	64
4.4.3.1.3	Print special masks	65
4.4.3.1.4	Produce individual max. intersection time plans	66
4.4.3.1.5	Print all	66
4.4.3.1.6	Print current error list	66
4.4.3.2	Print from controller	66
4.4.3.2.1	Single print	67
4.4.3.2.2	Print NOM	67
4.4.3.2.3	Print error report line by line	67
4.4.3.2.4	Print program change memory	67
4.4.3.2.5	Actual printing	68
4.4.3.2.6	Print error report line by line	68
4.4.3.2.7	Print program change line by line	69
4.4.3.3	PC print setup	69
4.4.4	?	69
4.4.4.1	User manual	69
4.4.4.2	Description of the menu symbols	70
4.4.4.3	Info	70

5.	Controller	71
5.1	Emergency controller EPB 12 / EPB 24 / EPB 48	71
5.2	Send data to controller	71
5.3	Import data from controller	71
5.4	Change parameters online	72
5.4.1	Green phase parameters	72
5.4.2	Progressive signalling	73
5.4.3	Switching times	74
5.5	Show outputs	75
5.6	Switching the monitoring functions	75
5.7	Set date and time	75
5.7.1	Set date and time manually	75
5.7.2	PC time	76
5.7.3	Radio clock	76
5.8	Test outputs	77
5.8.1	Trigger outputs	78
5.8.2	Automatic lamp output test	82
5.9	Power card information	83
5.10	User access	84
6.	Create program	85
6.1	Basic data	85
6.1.1	Program description	85
6.1.2	General data	85
6.1.3	Signal groups master data	86
6.1.3.1	Signal group name	86
6.1.3.2	Signal group type	87
6.1.3.3	Red-yellow / yellow phases	87
6.1.3.4	Min release	88
6.1.3.5	Clearance speed	88
6.1.3.6	Crossing time	88
6.1.3.7	Entry speed	88
6.1.3.8	Vehicle length	88
6.1.3.9	Flashing	89
6.1.3.10	Activate request mode	89
6.1.3.11	Blanking / capture signal	89
6.1.3.12	Transition times for blanking / capture signal	89
6.1.3.13	Changing the calculation parameters	90
6.1.3.14	Automatic signal safeguarding adjustment	91
6.1.4	Signal head equipment	92
6.1.4.1	Select signal head type	92
6.1.4.2	Select templates	93
6.1.4.3	Select user-defined templates	93
6.1.4.4	Select colour	94
6.1.4.5	Select diameter	94
6.1.4.6	Select lamp	95
6.1.4.7	Adapt individual signal head	95
6.1.4.7	Contrast visors	96
6.1.4.8	Copy signal head	97
6.1.5	Green flashing	98
6.1.6	Max. green phases	99
6.1.7	Program release	99
6.1.7.1	Default program release	99
6.1.7.1.1	No. of programs	100
6.1.7.1.2	Program names	100
6.1.7.1.3	Emergency program	100
6.1.7.1.4	Start program	100
6.1.7.1.5	Manual program	101
6.1.7.2	Advanced program release	101
6.1.8	Forced cycle	102
6.1.9	Activated groups	103
6.1.10	Map	104

6.1.11	Import map	104
6.1.12	Delete map	105
6.1.13	Save map	105
6.2	Interim times	106
6.2.1	Interlocking matrix (green interlocking)	107
6.2.2	Interim time calculation	108
6.2.2.1	Changing vehicle length	110
6.2.2.2	Change clearance speed	111
6.2.2.3	Changing the entry speed	112
6.2.2.4	Changing the Tc time	113
6.2.2.5	Increase the calculated value	114
6.2.2.6	Recalculating clearance with the standard values	115
6.2.3	Calculating additional lanes	116
6.2.3.1	Insert calculation of additional lanes	116
6.2.3.2	Calculate additional lanes	117
6.2.3.3	Remove calculation of additional lanes	118
6.2.4	Interim time matrix	119
6.2.4.1	Take interim time matrix from interim time calculation	119
6.2.4.2	Manual input in the interim time matrix	120
6.2.4.3	Asymmetrical interim time matrix	121
6.2.4.4	Create interlocking matrix automatically	121
6.3	Create a program	122
6.3.1	Determine cycle time and green phases according to traffic flow	122
6.3.1.1	Enter traffic flows	122
6.3.1.2	Change saturation flow	122
6.3.1.3	Create intersection time plans automatically according to traffic flow	123
6.3.2	Automatic intersection time plans	124
6.3.3	Intersection time plan editor	125
6.3.3.1	Working with the intersection time plan editor	126
6.3.3.2	Intersection time plan editor settings	127
6.3.3.3	Intersection time plan editor displays	127
6.3.3.4	Automatic interim time check	128
6.3.3.5	Measuring function	129
6.3.3.6	Drawing mode	130
6.3.3.7	Load / save draft	132
6.3.3.8	Load / save window draft	132
6.3.3.9	View min/max intersection time plan	133
6.3.4	Create intersection time plan	134
6.3.4.1	Draw green phase	135
6.3.4.1.1	Draw green phase	136
6.3.4.1.2	Draw green arrow	137
6.3.4.1.3	Draw continuous green	138
6.3.4.1.4	Define green flashing time	139
6.3.4.2	Draw blank	141
6.3.4.3	Draw combination of green and blank	141
6.3.4.4	Draw red	142
6.3.4.5	Draw continuous yellow	143
6.3.4.5.1	Draw pilot signal	145
6.3.4.6	Draw flashing	146
6.3.4.7	Draw alternate blinker	148
6.3.4.8	ON time (EZP)	149
6.3.4.9	OFF time (AZP)	149
6.3.4.10	Best/common switching point (GSP).	150
6.3.4.11	Additional GSP	151
6.3.4.12	Additional GSP only on request	151
6.3.5	Edit intersection time plan	152
6.3.5.1	Increase / end cycle time	152
6.3.5.2	Change red phase	153
6.3.5.3	Move intersection time plan	154
6.3.5.4	Fill intersection time plan	154
6.3.5.5	Adjust intersection time plan to min interim times	155
6.3.5.6	Adjust min. interim time to all signal groups	157
6.3.5.7	Define best cycle (automatically)	158

6.3.5.8	Define best cycle (semi-automatically)	160
6.3.5.9	Move group	163
6.3.5.10	Copy group	164
6.3.5.11	Insert group	164
6.3.5.12	Delete group	165
6.3.5.13	Move time	165
6.3.5.14	Change time	166
6.3.5.15	Change phase with green flashing range	167
6.3.5.16	Delete time	167
6.3.6	Vehicle actuation	168
6.3.6.1	Extension points for green phase extension	168
6.3.6.2	Waiting points for manual mode	170
6.3.6.3	Group on request	171
6.3.6.4	Jump over group	173
6.3.6.5	Leave group at green	177
6.3.6.6	Insert waiting signal	178
6.3.6.7	Yellow flashing / continuous yellow without request	179
6.3.7	Progressive signalling	180
6.3.7.1	Sync. input 2	180
6.3.7.1.1	Duration time sync. input	181
6.3.7.1.2	Sync. delay sync. input	182
6.3.7.1.3	Automatic bridging sync. input	182
6.3.7.2	Sync. input 2	183
6.3.7.3	Sync. output 1	184
6.3.7.4	Sync. output 2	184
6.3.7.5	Switch aux. relays	185
6.3.8	Switch-on programs	185
6.3.8.1	Switch-on program as program (bottleneck)	186
6.3.8.2	Switch-on program (larger than bottleneck)	187
6.3.8.3	Draw switch-on program as program	189
6.3.8.4	Switch-on program as steps	191
6.3.8.5	Draw switch-on program as steps	192
6.3.9	Specific switch-off programs	193
6.3.10	Error-off program	194
6.3.11	Transition programs	195
6.3.11.1	Transition program allocation	195
6.3.11.2	Allocate transition program	196
6.3.11.3	Edit transition program allocation	198
6.3.11.4	Draw transition programs	199
6.4	Special masks	200
6.4.1	Mapping detector inputs	200
6.4.2	Automatic detector presets	201
6.4.3	Delete request presets	201
6.4.4	Delete linked requests with green	202
6.4.4	Switch max. green	202
6.4.5	Set continuous requests	202
6.4.6	Switch max. extension time extension point 1	202
6.4.7	Switch max. extension time extension point 2	202
6.4.8	Set detector inputs	202
6.4.9	Suppress request	203
6.4.9.1	Activate the suppress request function	203
6.4.9.2	Deactivate the suppress request function	203
6.4.9.3	Deactivate the suppress request function in cycle second	204
6.4.9.4	Blocking time	204
6.4.9.5	Suppress request by contact control	204
6.4.10	Program change on request EPB	205
6.4.10.1	Request program change on request EPB	205
6.4.10.1.1	Request block	206
6.4.10.2	Cleardown for program change on request EPB	206
6.4.10.2.1	Cleardown for program change on request EPB after time	206
6.4.10.3	Subsequent request for program change on request EPB	206
6.4.10.4	Program change on request EPB per contact control	206
6.4.11	Program change on request MPB 4xxx	207

6.4.12	Program change extended on request / blanking	209
6.4.12.1	Stipulate basic setting	209
6.4.12.2	Request program change extended on request / blanking	210
6.4.12.3	Channel allocation	210
6.4.12.4	Enable channel in seconds / program in seconds	211
6.4.12.5	Functioning of the channels	211
6.4.12.5.1	Functioning of extended program change on request	211
6.4.12.5.2	Functioning of blanking	211
6.4.12.6	Preemption	212
6.4.12.6.1	Priority lock	212
6.4.12.7	Request options	212
6.4.12.7.1	Detector presets	212
6.4.12.7.2	Delete preset groups	212
6.4.12.7.3	Trigger continuous red / preemption	213
6.4.12.7.4	Preemption contact control	213
6.4.12.7.5	Premature cleardown	213
6.4.12.7.6	Forced trigger	214
6.4.12.8	Cleardown for program change extended to request / blanking	214
6.4.12.8.1	Cleardown for program change extended on request / blanking in seconds	214
6.4.12.8.2	Cleardown for program change extended on request / blanking after time	214
6.4.12.9	Request options	214
6.4.12.9.1	Back to basic setting	215
6.4.12.9.2	Detector presets	215
6.4.12.9.3	Delete preset groups	215
6.4.12.10	Program change extended on request / blanking by contact control	215
6.4.12.11	Display notifications for program change extended on request / blanking	215
6.4.13	End extension prematurely	216
6.4.13.1	Activate end extension prematurely	216
6.4.13.2	Deactivate end extension prematurely	217
6.4.13.3	Deactivate end extension prematurely at cycle second	217
6.4.13.4	Special functions: cancel extension prematurely	217
6.4.13.5	Counter start at stopping point / start when triggered	218
6.4.13.6	End extension prematurely with contact control	218
6.4.13.7	End extension prematurely displays	218
6.4.14	Continuous red / preemption	219
6.4.14.1	Activate continuous red / preemption	219
6.4.14.2	Continuous red - continue in second	220
6.4.14.3	Jump to second	220
6.4.14.4	Special function for jump to second with stopping point	220
6.4.14.5	Preemption	221
6.4.14.6	Deactivate continuous red / preemption	221
6.4.14.7	Continuous red / preemption with contact control	221
6.4.14.8	Continuous red / preemption options	222
6.4.14.8.1	Proceed with detector presets	222
6.4.14.8.2	Delete request presets	222
6.4.14.9	Request block	222
6.4.14.10	Continuous red / preemption displays	222
6.4.15	Manage outputs	223
6.4.15.1	Move outputs	223
6.4.15.2	Editing manage outputs	224
6.4.15.3	Deleting manage outputs	225
6.4.15.4	Example move outputs	225
6.4.16	Group mapping list EPB 12	226
6.5	Parameter lists	227
6.5.1	Parameter lists names	227
6.5.2	Extension time 1	228
6.5.3	Extension time 2	229
6.5.4	Options parameter lists	230
6.5.4.1	Deactivate parameter lists	230
6.5.4.1.1	Select program manually / externally	230
6.5.4.1.2	Change operating mode	231
6.5.4.1.2.1	Clock mode / flashing (keyboard)	231
6.5.4.1.2.2	Emergency program	231

6.5.4.2	Behaviour for active special masks	232
6.6	Number of signal heads	233
6.7	Signal safeguarding	233
6.7.1	Mixed mode signal heads / blind module	233
6.7.2	Signal safeguarding EPB 24 / EPB 48	234
6.7.2.1	Number of power cards	235
6.7.2.2	Lamp monitoring	236
6.7.2.3	Status monitoring	236
6.7.2.4	Controller error off	236
6.7.2.5	Example lamp monitoring (error)	237
6.7.3	Signal safeguarding EPB 12	238
6.7.4	Red lamp monitoring MPB 4xxx	239
6.8	Radio clock / Progressive signalling	240
6.8.1	Function sync. inputs	240
6.8.2	Radio clock parameters	241
6.8.2.1	Recalculation procedure	241
6.8.2.2	Offset time	241
6.8.3	Radio clock protocol mode	242
6.8.3.1	Operating mode	242
6.8.4	Radio clock type BCD	243
6.8.5	Serial radio clock	243
6.9	Program switching points	244
6.9.1	Weekly automatic clock mode	244
6.9.2	Weekly automatic radio clock	245
6.9.2.1	Weekly schedules / day's schedules	246
6.9.2.1.1	Enter day's schedules	246
6.9.2.1.2	Switch parameter lists / special functions	248
6.9.2.1.3	Enter weekly schedules	249
6.9.2.1.4	Weekly schedule error display	250
6.9.2.1.5	Clock mode for weekly schedules	250
6.9.2.2	Public holidays	251
6.9.2.2.1	Enter fixed public holidays	251
6.9.2.2.2	Enter floating public holidays	252
6.9.2.2.3	Enter public holidays by state	253
6.9.2.3	Special switching points	254
6.9.2.3.1	Enter special switching points	255
6.9.2.3.2	Error display for public holidays and special switching points	258
6.10	System functions	259
6.10.1	Configuring the relay outputs	259
6.10.1.1	Error outputs	259
6.10.1.1.1	Error output as continuous signal	259
6.10.1.1.2	Error output as pulse	259
6.10.1.2	Sync. outputs	260
6.10.1.2.1	Sync. relay inactive after fault	260
6.10.1.2.2	Sync. relay ON after fault	260
6.10.1.2.3	Switch only at SZP	260
6.10.1.3.3	Sync. relay continuous signal	260
6.10.2	Display illumination	261
6.10.3	TLS off	261
6.10.4	Duration print function	261
6.10.5	Automatic restart after error	261
6.10.5.1	Restart time after error	261
6.10.5.2	Restart in minutes	261
6.10.5.3	No restart after error	262
6.10.5.4	Restart immediately after a fault	262
6.10.5.5	No. restarts after error	262
6.10.6	Baud rate printer interface	262
6.10.7	Miscellaneous functions	262
6.10.7.1	Groups preset for manual mode	262
6.10.7.2	Send no message for progressive signalling inputs	263
6.10.7.3	Send test or check results to operating logbook	263
6.10.7.4	All groups preset when emergency program active	263
6.10.7.5	Max green when emergency program active	263

6.10.7.6	All groups preset once with manual program choice	263
6.10.7.7	External fault input: contact control	264
6.10.7.8	Show informative error reports	264
6.10.7.9	Extend trigger for program change on request	264
6.10.8	Auxiliary signals	265
6.10.8.1	Output waiting signal	265
6.10.8.2	Output acknowledge signals	265
6.10.9	Active special inputs	266
6.10.10	Function additional relay PWK 24 / PWK 48	267
6.10.10.1	Relay 1 for green / relay 2 for waiting signal	267
6.10.10.2	Manual switching	267
6.10.11	Adjust time according to radio clock	267
6.10.12	LED Panel	267
6.10.13	Special functions: sync. points	268
6.10.14	External programs	268
6.10.14.1	External programs mode: contact control	269
6.10.14.2	External programs mode: end automatically	269
7.	<i>CPU simulation</i>	270
7.1	Simulation function	270
7.1.1	Simulation query	270
7.1.1.1	Simulate created program	270
7.1.1.2	Simulate current program	270
7.1.2	Simulation window	271
7.1.3	Simulate program	271
7.1.3.1	Basic operation	271
7.1.3.2	Check program	272
7.1.3.3	Progressive signalling / additional displays	272
7.1.3.4	Check signal safeguarding	273
7.1.3.4.1	Start simulation after fault	273
7.1.3.4.2	Lamps defective	273
7.1.3.4.3	Interlocking matrix	274
7.1.3.4.4	Status error	274
7.1.3.4.5	Red / green error	274
7.1.3.5	Change CPU date / time	275
7.1.3.6	Clear error memory	275
7.1.3.7	Select program radio clock / external	276
8.	<i>CPU protocol</i>	277
8.1	Protocol	277
8.1.1	Write protocol	277
8.1.2	Data flow control	277
8.1.3	Display graphical data during transfer	278
8.1.4	Save protocol	278
8.2	Analyse protocol	279
8.2.1	Selection menu analysis window	280
8.2.2.1	File	280
8.2.2.2	Print	280
8.2.2.3	Seconds display	280
8.2.2.4	View	281
8.2.3	Measuring function	282
8.2.4	Display with green phase extension	283
8.2.5	Display with continue time (progressive signalling)	284
8.2.6	Display with jump (group on request)	284
8.3	Printing data from controller	285
8.3.1	Record print data	286
8.3.2	Save print data	287
8.3.3	Use print data	287

9.	Check signal safeguarding	288
9.1.1	Check signal safeguarding	288
9.1.2	Legend feedback symbols	293
9.1.2.1	Check green-green interlocking	293
9.1.2.2	Check status monitoring	293
9.1.2.3	Check lamp defect	294
9.1.3	Check green/green interlocking	295
9.1.3.1	External check of green/green interlocking	298
9.1.3.2	Error OFF when checking green/green interlocking	299
9.1.4	Check status monitoring	300
9.1.4.1	External check of status monitoring	301
9.1.4.2	Error OFF when checking status monitoring	302
9.1.5	Check lamp defect	303
9.1.5.1	Check lamp monitoring	304
9.1.5.2	Check red lamp monitoring logic OR	305
9.1.5.3	Check red lamp monitoring AND	306
9.1.5.4	Check lamp monitoring for several power cards	308
9.1.5.4.1	Card logic OR / group logic OR	308
9.1.5.4.2	Card logic OR / group logic AND	309
9.1.5.4.3	Card logic AND / group logic AND	311
9.1.5.4.3	Card logic AND / group logic OR	312
9.1.5.5	Error OFF when checking lamp defect	314
9.1.6	Auto test	315
9.1.6.1	Auto test option	318
9.1.6.2	Error OFF during active auto test	318
9.1.7	Protocolling test results for checking signal safeguarding	319
9.1.7.1	Save signal safeguarding protocol	319
9.1.7.2	Miscellaneous	319
9.1.8	Analyse signal safeguarding check	320
9.1.8.1	Load protocol file	320
9.1.8.2	Save protocol file as	320
9.1.8.3	Print protocol file	321
9.1.8.4	Print marked area	321
9.1.8.5	Save marked area	321
10.	Configuration local public transport module	322
10.1	Tools	323
10.1.1	New configuration	323
10.1.2	Load data	323
10.1.3	Save data	323
10.1.4	Print data	323
10.1.5	Send data to the local public transport receiver	324
10.1.6	Read data from the local public transport receiver	324
10.1.7	Query operating mode	325
10.1.8	Query message filter	325
10.1.9	Query frequency	325
10.1.10	Query logging points	325
10.1.11	Delete all logging points	325
10.2	Location	326
10.3	Operating mode	326
10.3.1	Send operating mode	326
10.4	Reception frequency	326
10.4.1	Send reception frequency	326
10.4.2	Add reception frequency	327
10.4.3	Delete reception frequency	328
10.5	Message filter	328
10.5.1	Send message filter	328
10.6	Logging points	328
10.6.1	Delete logging points	328
10.6.2	Send logging point	329
10.7	Feedback window	329
10.7.1	Clear feedback window	329

10.8	Transmission display	329
11.	Annex	330
11.1	Calculation example for entering a bottleneck system	330
11.2	Calculation example for entering a T-junction system	359
11.3	Calculation example for entering a crossroads system	386
11.4	Calculation example for entering a pedestrian traffic light system	386

1. Installation

1.1 System requirements

IBM-compatible computer and operating system from 10 (64 bit), mouse, keyboard, colour monitor, minimum resolution **1024 x 600** or higher (min. 16 bit colour depth), printer, serial interface, alternative USB/serial converter.
Optimized for scaling up to 175%

1.2 Software CD

An installation program begins automatically on inserting the CD. For installation, please follow the instructions of the installation program. If contrary to expectation the installation menu does not appear, please execute the program manually with a double click on the program **Setup_Ampeltools_3.20.exe** in the main directory of the CD.

1.3 Activate program

The program and the additional modules are activated via a software dongle.
Use of the program is restricted without a software dongle.
Only the **Load data**, **Send data to controller** and **Emergency control functions** are then available.

1.4 Select language

After the program has been activated, the display language of the software is recognised immediately. The current system language is always the default.

The selection menu offers a choice between the following languages:

- German
- English
- system (current system language)



Any change in display language is only activated after the next restart. The following information appears:

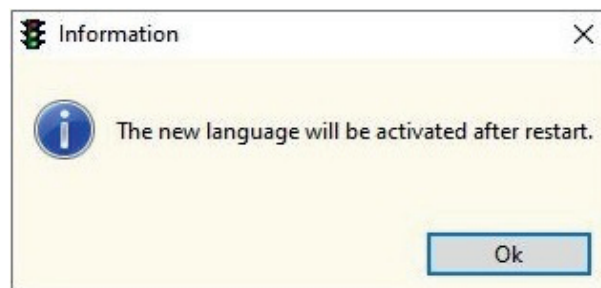

Note:

If a language other than German is chosen and the language file is missing, the display language is always adjusted to German.

The following message appears:

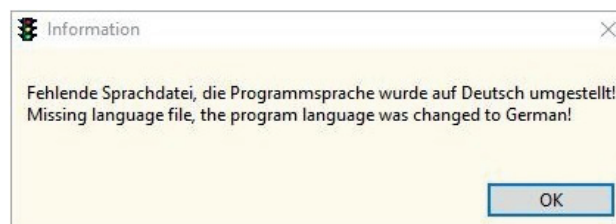

1.5 Controller support

This software can be used for the following Berghaus controllers (in the fixed phase with VA mode):

- EPB 12 / EPB 24 / EPB 48
maximum 24 groups / 6 day time programs, depending on controller and software version
- MPB 44 M
maximum 12 groups, maximum 24 signal heads / 4 day time programs
- MPB 4400 / 4000 cable
maximum 12 groups, maximum 24 signal heads / 4 day time programs
- MPB 4400 / 4000 radio
maximum 4 groups, maximum 4 signal heads / 4 day time programs
- MPB 4400 / 4000 radio – 8F export version from version P10.01 – 14:00
maximum 8 groups, maximum 8 signal heads / 4 day time programs

Note:

The minimum cycle time for all controller types is 240 seconds. Entries for the interim time matrix are limited to 99 seconds.

In addition, the software can be changed to **Free program planning**. In this case, up to 32 groups are supported with up to 12 day time programs. All entry values are limited to maximum 999 seconds. System-related masks are then hidden.

1.6 Error report tool

The software includes a tool that records any program crashes. The following window appears when the program crashes.

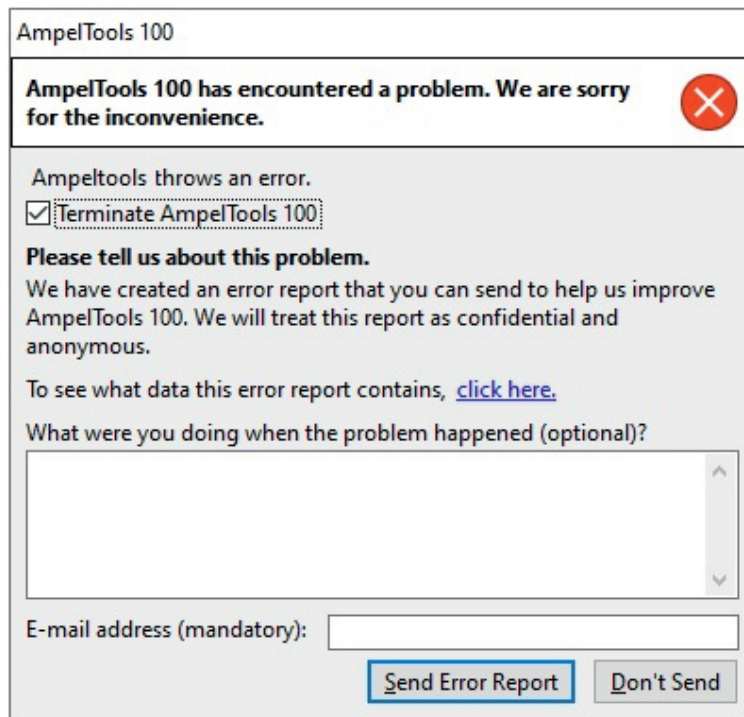

The screenshot shows a dialog box titled "AmpelTools 100". The main message reads: "AmpelTools 100 has encountered a problem. We are sorry for the inconvenience." Below this, it states "Ampeltools throws an error." and provides a checked checkbox for "Terminate AmpelTools 100". The dialog then asks the user to "Please tell us about this problem." and explains that an error report has been created for improvement purposes, which will be confidential and anonymous. A link "click here" is provided to view the report's contents. A text area is labeled "What were you doing when the problem happened (optional)?". At the bottom, there is a mandatory "E-mail address" input field and two buttons: "Send Error Report" and "Don't Send".

As software user, you can then send the error report automatically to Berghaus if you so want. Please enter your e-mail address (mandatory) in the input box **E-mail address (mandatory)**. In this case, click on **Send Error Report**. This takes you automatically to the standard e-mail program.

It is presumed that an internet link exists.

To see the content of the error report being sent, **click here** with the left mouse button.

If you do not want to send the report, click on **Don't Send**. In both cases, "Ampeltools" is then closed down.

2. Program settings

2.1 General settings

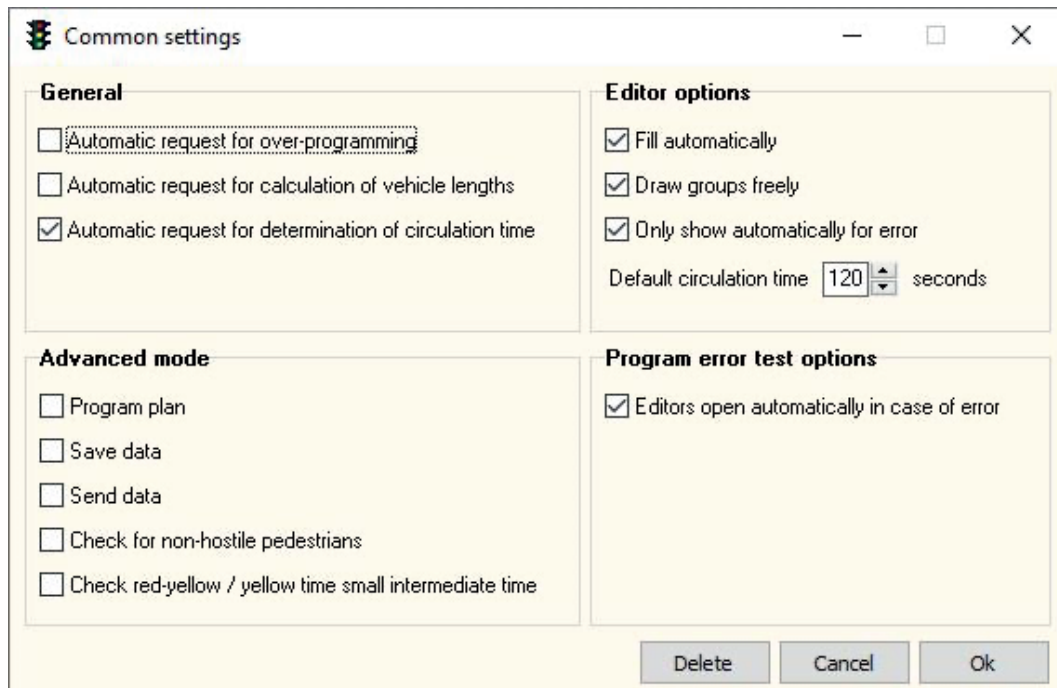

2.1.1 Automatic query about over-programming

If this function is enabled, a query about configuring the **Over-programming** function always appears on calling up Save / Save as or Send data.

2.1.2 Automatic query about calculating vehicle lengths

If this function is enabled, a query about calculating interim times with vehicle lengths appears every time the program starts or when the new program function is selected. Depending on the answer, the calculation setting is changed and the corresponding option is enabled, ↗ [4.1.1.1](#)

2.1.3 Automatic query about determining circulation time

If this function is enabled, when the intersection time plan editor is selected, a query appears whether the cycle times and green phases should be compiled according to the existing traffic volumes.

Confirmation with **Yes** opens the corresponding entry mask. ↗ [6.3.1](#)

Note:

This request only appears if interim times exist and the number of groups is two.

2.1.4 Advanced mode

This selection box offers various options for the advanced mode for experts to use. In the advanced mode, standard functions can be changed selectively, such as specific guidance through entry masks, automatic check for missing data before saving/sending data or whether hostile pedestrian groups should be added to vehicle groups.

To return to the standard function, remove the advance mode tick set at the previously selected menu points.

2.1.4.1 Program plan

The sequence of entry masks for data input is fixed in the standard functions. You cannot call the next entry mask until you have entered the corresponding data in the previous mask.

If you select any entry mask at random, a corresponding message appears telling you which data have to be entered first.

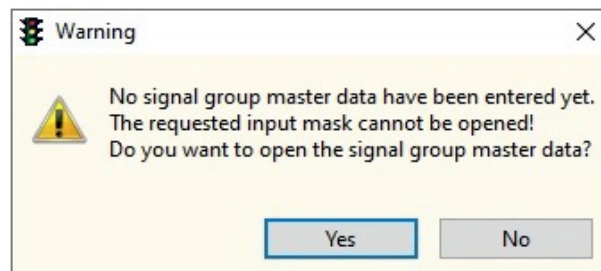

Confirmation with **Yes** always opens the entry mask where data input is expected according to the fixed sequence.

As expert, you can ignore the fixed sequence of entry masks by enabling the **Advanced mode** for this menu point with a tick. You can then select all menu points in the menu structure.

To return to the standard function, remove the advance mode tick set at this menu point.

2.1.4.2 Save / send data

In the standard functions, the system checks whether necessary data are missing every time data are saved or sent.



If this message is confirmed, an error list occurs with all missing entries.

The message closes automatically when the error list is empty.

If you select **Edit**, the corresponding entry mask opens with the marked entry.

If you close the mask with **OK** it is deleted from the list. The system does not check whether data were entered. If you select **Ignore**, the entry is also deleted from the error list without the entry mask opening.

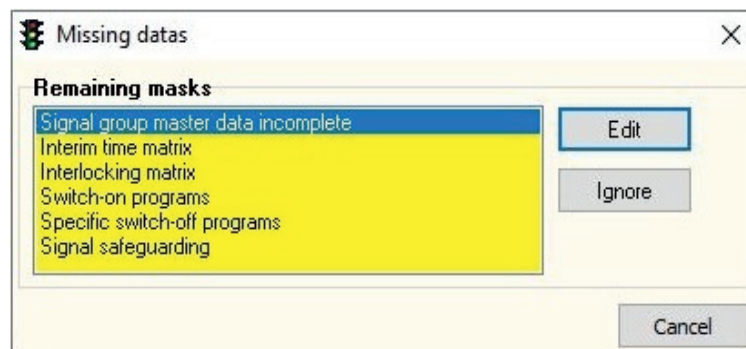

This check function can be enabled/disabled separately for saving and sending data.

As expert, you can switch this automatic check off by enabling the **Advanced mode** for this menu point with a tick. No checks for missing data are then carried out when saving or sending data.

To return to the standard function, remove the advance mode tick set at this menu point.

Note:

If this window is closed and entries are still present, the previously selected function is not carried out.

2.1.4.3 Check for non-hostile pedestrians

In the standard functions, every time the intersection time plan editor is closed and during the final check, the system checks whether non-hostile pedestrian groups are added to vehicle groups.

As expert, you can switch this automatic check off by enabling the **Advanced mode** for this menu point with a tick. In this case, the system no longer checks whether non-hostile pedestrian groups are added to vehicle groups.

To return to the standard function, remove the advance mode tick set at this menu point.

2.1.4.4 Check red-yellow / yellow time small intermediate time

The final test checks whether the sum of the yellow time of the ending signal group and the red-yellow time of the beginning signal group is greater than the corresponding intermediate time.

As expert, you can switch this automatic check off by enabling the **Advanced mode** for this menu point with a tick.

To return to the standard function, remove the advance mode tick set at this menu point.

2.1.5 Editor options

Various basic settings/defaults for the graphic editors are adjusted here.

2.1.5.1 Fill automatically

If this function is enabled, the red phase is automatically filled in the intersection time plan editor. If it is disabled, only the selected phase (colour) and the red-yellow and yellow-phases are drawn (if present).

The function for filling the intersection time plan fills the rest of the phase with red.

2.1.5.2 Draw groups freely

This function can be used to choose between two types of drawing.

If draw freely is enabled, then the groups are drawn freely in the intersection time plan editor.

The chosen phase (colour) is then filled automatically when drawing.

If draw freely is disabled, then only the initial time is selected; once the end time has been defined, the active group is then drawn with the corresponding phases (colours).

Note:

This option should be disabled if your screen flickers excessively when drawing (inadequate graphic card).

2.1.5.3 Only show automatically for error

This setting selects whether the intersection time plan editor should appear automatically after every change (e.g. yellow phase) or only if an error has occurred after a change (e.g. interim times error).

2.1.5.4 Default circulation time

The value adjusted here acts as the default for the cycle time in the intersection time plan editor and for the switch-on/switch-off programs when these are opened and no data are available yet.

2.1.6 Program error test options

Various basic settings for program error checking are adjusted here. Program error checking is always carried out when data are saved, loaded, exported from the controller or imported.

2.1.6.1 Editors open automatically in case of error

This option can be used to choose whether the respective editors should open automatically in case of error. If the option is disabled, a confirmation query appears.

2.2 Signal group defaults

The signal group defaults for the signal group master data are adjusted in this window.

Note:

This function is only available from Ampeltools version 1.20.

	Red-yellow	Yellow	Min release	Clearance speed	Passage time	Entry speed	Vehicle length (m)
Car, truck, bus:	1	4	10	30 km/h (8,333 m/s)	4	40 km/h (11,111 m/s)	6
Pedestrian:	0	0	8	1,2 m/s	0	1,5 m/s	0
Cable car:	0	0	10	30 km/h (8,333 m/s)	5	20 km/h (5,556 m/s)	15
Green arrow:	0	0	10	30 km/h (8,333 m/s)	4	40 km/h (11,111 m/s)	6
Cyclist:	1	4	10	4 m/s	1	5 m/s	6
Aux. signal:	0	0	0	0 m/s	0	0 m/s	0

Note:

The currently adjusted profile appears in the header of the signal group master data. The values for **Aux. signal** cannot be changed!

2.2.1 Profile

This selection function is used to adjust different profiles with defaults. The adjusted profile then always appears as the standard for the **Signal group master data** with the corresponding values.

2.2.1.1 Standard profile

The **Standard** profile is adjusted during installation and cannot be changed or deleted. This profile is the standard setting. Other values can be adjusted by creating own profiles.

2.2.1.2 Own profiles

Any number of profiles can be created using the following buttons:

-  New entry: this enables the entry mode so that changes can be made in all input boxes.

Note:

The **New entry** function is only possible if the **Standard** profile is adjusted.

-  Edit the marked entry: this enables the entry mode so that changes can be made in all the input boxes.

-  Save profile as: this ends the entry mode with a query for the name of the profile. After entry and confirmation, click on **OK** to save the profile under the entered name. It then appears in the selection box.

Note:

If you have edited an existing profile, when you click on **Save** you will be asked whether it should be overwritten.

-  Delete current profile: a corresponding query appears before deleting. Click on **OK** to delete the current profile. It is then removed from the selection box. The **Standard** profile then appears as default.

2.3 Print settings

All print functions are adjusted in this window.

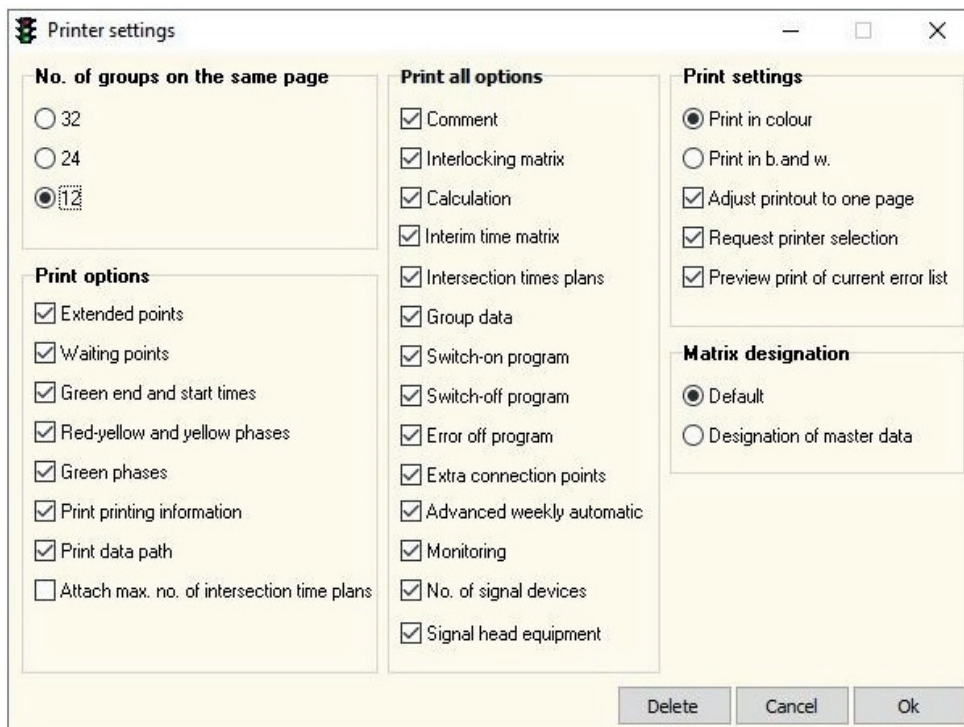

Printer settings

No. of groups on the same page

32

24

12

Print options

Extended points

Waiting points

Green end and start times

Red-yellow and yellow phases

Green phases

Print printing information

Print data path

Attach max. no. of intersection time plans

Print all options

Comment

Interlocking matrix

Calculation

Interim time matrix

Intersection times plans

Group data

Switch-on program

Switch-off program

Error off program

Extra connection points

Advanced weekly automatic

Monitoring

No. of signal devices

Signal head equipment

Print settings

Print in colour

Print in b. and w.

Adjust printout to one page

Request printer selection

Preview print of current error list

Matrix designation

Default

Designation of master data

Delete Cancel Ok

2.3.1 No. of groups on a page

Here you can choose how many groups are printed on one page. Depending on your choice, some print options are disabled or enabled.

Note:

This setting does not influence the setting Printout to one page.

2.3.2 Print options

The print option defines which additional information is printed in the intersection time plan. Extended points and waiting points (manual lock-in points) are shown as symbols. The information for green end and start times, red-yellow / yellow phases and green phases are shown in or at the end of the intersection time plan.

The option Print printing information decides whether the top footer should be printed on the printouts. This contains the software version and print date.

The program name and data path are also printed if the option Print data path is enabled.

If the function Attach max. intersection time plan is enabled, the max. intersection time plan is automatically printed after the min. intersection time plan.

Note:

For space reasons, the following values cannot be printed if more than 12 groups are to be printed on a page:

- Green end and start
- Red-yellow / yellow phases
- Continuous green phase

2.3.3 Print all

This selection stipulates which program data are printed on selecting **Print all**.

2.3.4 Print settings

You can adjust whether all printouts (PC data) are printed in colour or in black-and-white.

If you have enabled Adjust printout to one page, the printouts of the phase plans are adjusted to one page. If it is disabled, maximum 120 seconds per page are printed.

If you have enabled Request printer selection, then a selection dialogue appears every time you start printing (PC data).

If you have enabled Preview print of current error list, a print preview appears first.

If this is disabled, the printout is done immediately on the adjusted printer.

Note:

If the function is activated, the number of printouts can get unmanageable, depending on the length of the cycle time (maximum 999 seconds).

2.3.5 Matrix name

This defines the name used in the printout for the signal group in the interim time matrix and interlocking matrix.

If set to Default, the name of the matrices is sorted numerically (1 - 32).

If From master data (name) is enabled, the first 4 characters from the master data (name) are used.

2.4 Data storage

Used to adjust the respective data storage:

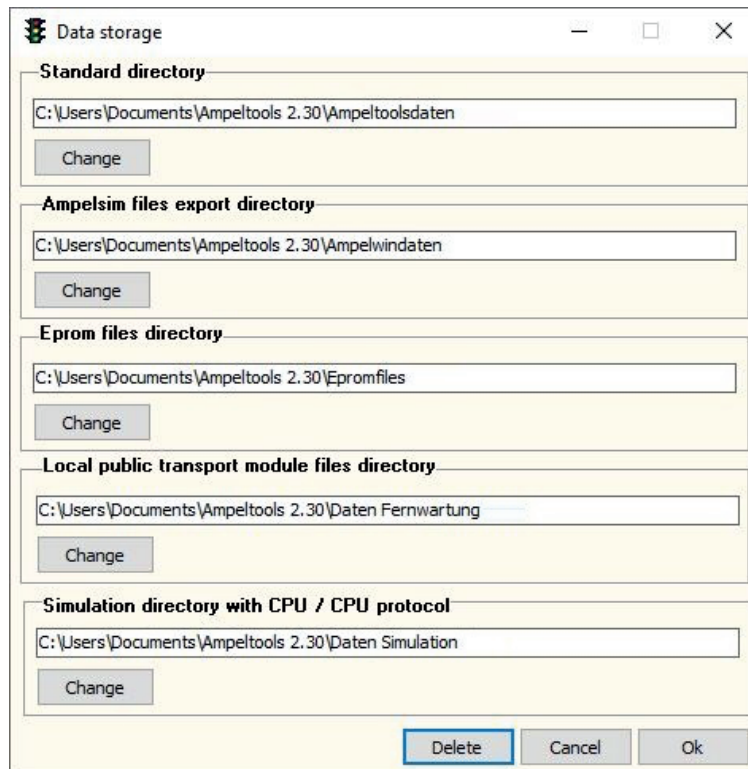

2.4.1 Standard directory

The adjusted directory is used to load or save the Ampeltools program data.

2.4.2 Ampelsim files export directory

States the import directory for the Ampelwin files, the program commentary and the Ampelwin e-mail files. The directory adjusted here is then used to search for the corresponding files.

Note:

The adjusted directory is also used for saving files with Save Ampelsim data. [☞ 4.4.1.5](#)

2.4.3 Eprom files directory

This directory is used to generate the monitoring files. They can be burnt with an Eprom burner.

2.4.4 Directory local public transport module

The adjusted directory is used to load or save the program data of the local public transport module.

2.4.5 CPU simulation / CPU protocol directory

This directory is used to save all files generated during CPU simulation, CPU protocol or when signal safeguarding is being tested.

2.4.6 Create directory

If you select **Change** in the respective directory setting, the following window appears to create the required directory:

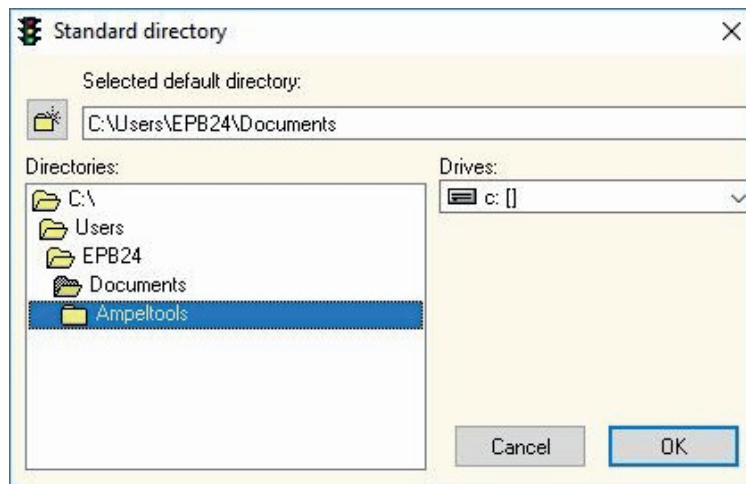

Click on **OK** to save the created directory that then appears accordingly in the settings.

2.5 User data

The screenshot shows a window titled "User data" with a standard Windows-style title bar (minimize, maximize, close buttons). The window is divided into three main sections. The top section, titled "User data", contains several text input fields: "Company:", "Street:", "Postcode:", "City:", "Tel. No.:", "Fax No.:", and "Email:". The middle section is split into two parts. On the left, titled "Logo", there is a large empty rectangular box, a checkbox labeled "No logo", and a blue-bordered button labeled "Change". On the right, titled "User code", there is a text input field and a checkbox labeled "Generate automatically". At the bottom of the window, there are three buttons: "Delete", "Cancel", and "Ok".

The user data that appear in the footer of every printout are entered here.

You can also select an existing company logo. This then appears next to the user data in the footer of every printout.

Select **Change** to see a dialogue for selecting the required image file.

Click on **Open** to insert the marked file as logo. It is adjusted automatically to the required size.

If you select **No logo**, the adjusted logo is deleted again. No logo appears on the printout.

Enter the required user code in **User code**. This only appears while making the entry. It appears encrypted on leaving the box or opening the mask. To change the user code, it has to be overwritten.

If Show automatically is enabled, the entered user code is automatically preset for the following online functions:

- Export data to controller
- Import data from controller
- Change parameters online (only EPB 12 / EPB 24 / EPB 48)

Exception:

Switch monitoring and remote maintenance: in this case, the user code has to be entered manually for security reasons.

2.6 Additional modules

The individual additional modules are activated automatically via the plugged-in software dongle.

2.6.1 CPU simulation

If this module is activated, a program can be simulated with a separate CPU. All functions such as sequence, monitoring etc. can be tested from the PC. For other functions see CPU simulation. ↗ 7.1

Note:

This function is only supported from version 6.50 (EPB 12 / EPB 24 / EPB 48).

2.6.2 CPU protocol

This module produces a protocol of a running program from the controller so it can be shown graphically.

If this module is activated, choosing **CPU protocol** is enabled. For other functions, see CPU protocol. ↗ 8.1

2.6.3 Check signal safeguarding

This module can be used to check current signal safeguarding in the controller. If the module is activated, choosing **Check signal safeguarding** is enabled. For other functions, see **Check signal safeguarding**. ↗ 9.1

Note:

This function is only supported from version 6.90 (EPB 12 / EPB 24 / EPB 48).

2.6.4 Enable training

This option is only visible if not all additional modules have been activated. If selected, training is enabled so that all program functions including all additional modules can be tested for 10 hours or until the program stops.

Note:

The additional modules **CPU simulation**, **CPU protocol** and **Check signal safeguarding** cannot be selected if the corresponding interface is set to **None**.

2.6.5 Deactivate program

This function deactivates the program. If selected, a query appears on closing the windows to check whether enabling the program is to be deactivated. If the query is answered with **Yes**, next time the program starts, this software will have to be activated again including the additional modules.

2.7 CPU simulation / Emergency controller

This mask is used to adjust all settings for CPU simulation respectively in the emergency controller.

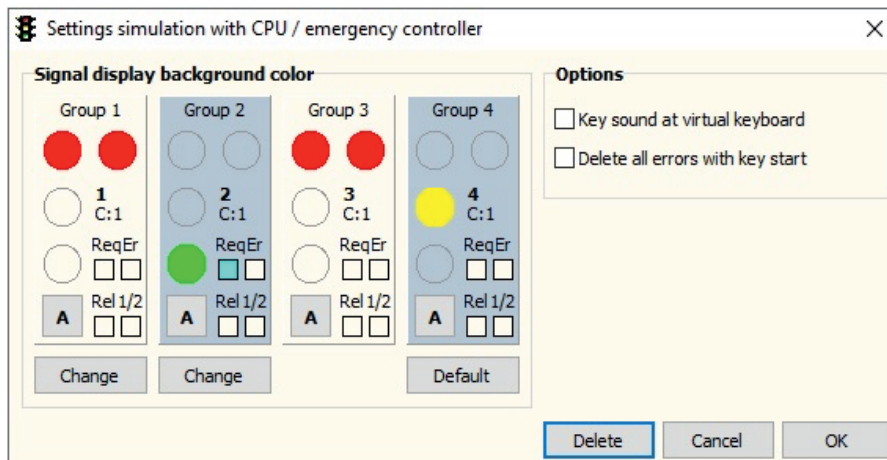

Note:

This function is available for EPB 12 / EPB 24 / EPB 48 from version 6.50.

2.7.1 Signal display background colour

If you click on one of the **Change** buttons, a colour choice menu appears for adjusting the required background colour of the signal heads in the simulation interface. The adjustment is made separately for even-numbered and odd-numbered groups. Click on the corresponding **Change** button. Click on **Default** to reset the background colours to the factory defaults.

2.7.2 Options

2.7.2.1 Key sound at virtual keyboard

If this function is enabled, a confirmation sound can be heard on using the keyboard of the emergency controller, simulation or remote controller.

2.7.2.2 Start deletes all errors

If this option is enabled, click on **Start** to delete all simulated faults in the simulation interface and the error in the simulation CPU: simulation then starts again (automatically). If this function is disabled, all faults in the simulation interface have to be eliminated manually before the error in the simulation CPU can be deleted and the simulation restarted.

3. Operating instructions

3.1 General

After the program has started, the main window opens with the following basic settings (some settings are saved on closing Ampeltools):

- Interim times = calculated without vehicle lengths
- Operating mode = fixed time with VA
- Interfaces = last setting (default = none)
- Controller type = last setting (default = EPB 24)
- Version = last setting (default = 7.5x)
- No. of groups = 2

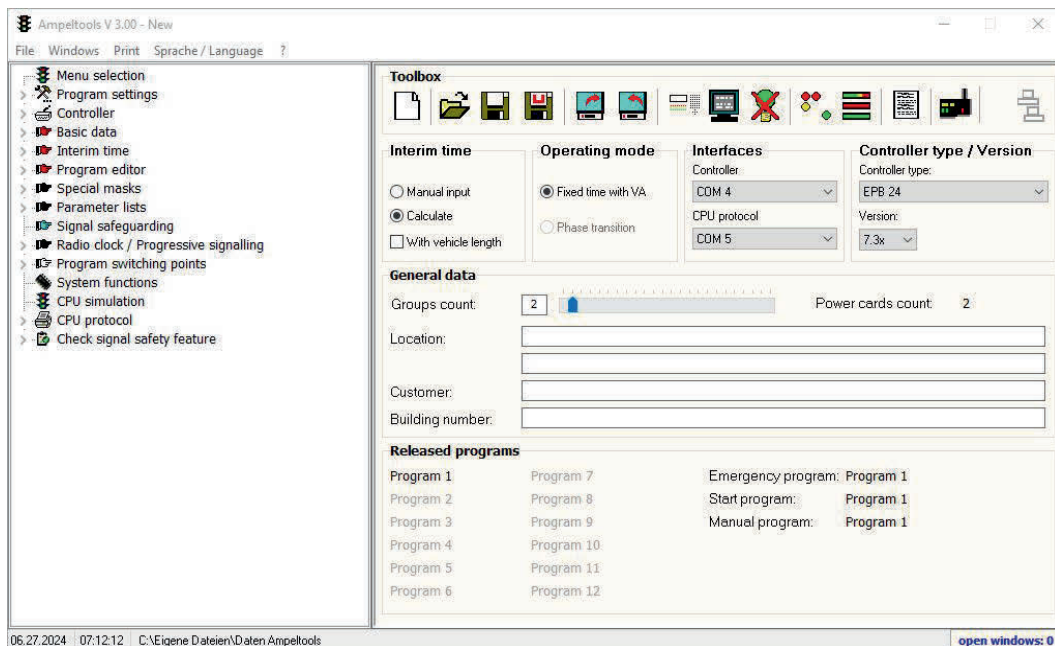

The main window breaks down into different sections

- **Main menu**
Certain functions can be selected in this menu, e.g. import functions and all print functions.
- **Navigation**
The navigation lists all entry masks for the program data and settings etc. for selection. The structure varies according to controller type. The navigation list always closes every time you change over to another controller type.
- **Toolbox**
Direct access to the main functions, such as loading and saving data, data transfer between PC and controller, emergency controller, CPU protocol and CPU simulation.

- **Controller type**
Select the required controller type and its version.
- **General data**
Basic data for the current program, e.g. no. of groups, location etc.
- **Released programs**
Shows the released programs as well as the emergency, manual and start program (depending on controller type). These data are entered under the heading Basic data in the menu point General data. ↗ 6.1.7

Notes:

- Click on **F12** in any activated window to put the main window in the foreground.
- Depending on controller type and adjusted version, input boxes that are not needed are cross-hatched in some entry masks, to make entries easier. Entries are then only possible where currently supported.

3.1.1 Select controller type

The required controller type / version is selected here.

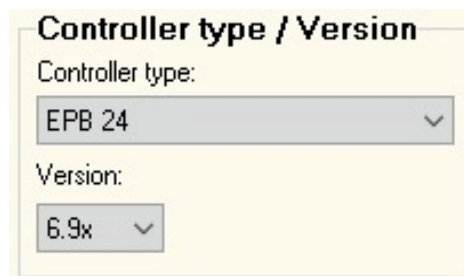

The screenshot shows a dialog box titled "Controller type / Version". It contains two dropdown menus. The first is labeled "Controller type:" and has "EPB 24" selected. The second is labeled "Version:" and has "6.9x" selected. Both dropdown menus have a small downward arrow on the right side.

Any existing data are checked to see whether they are supported by the selected controller type. If this is not the case, corresponding queries or messages appear with information about which functions are not supported.

If the query is confirmed, data are deleted or functions disabled depending on the selected controller type.

3.1.2 Check interim time automatically

When one of the entry masks signal group master data, interlocking matrix, interim time calculation or the interim times matrix is closed, the system checks for interim time errors in all released intersection time plans and in the switch-on or specific switch-off programs. If interim time errors are found, the corresponding editor opens automatically.

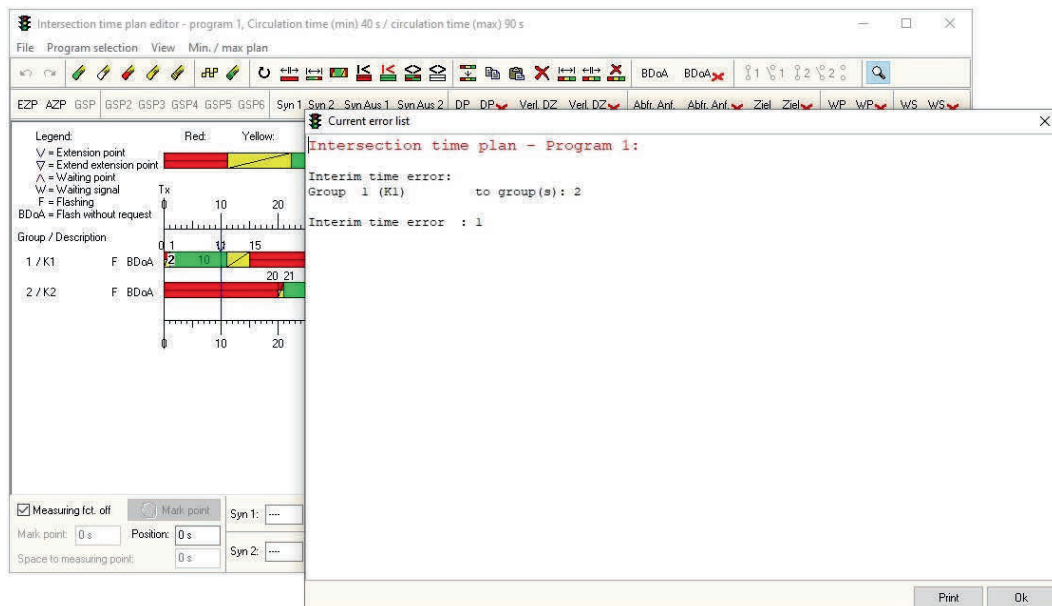

In addition, an information list also appears with all interim time errors, stating which program, the affected groups and the corresponding signal group name. Click on **Print** to print the displayed errors on the printer connected to the PC.

Note:

This check is also carried out when a program is imported, loaded or read from the controller. If two hostile groups have green together, the error is shown as an overlap.

3.1.3 Check intersection time plan automatically for faulty functions

As well as checking the interim times automatically, another check examines all released intersection time plans for faulty or invalid entries.

This is always carried out on closing the intersection time plan.

Everything is entered in a corresponding error list.

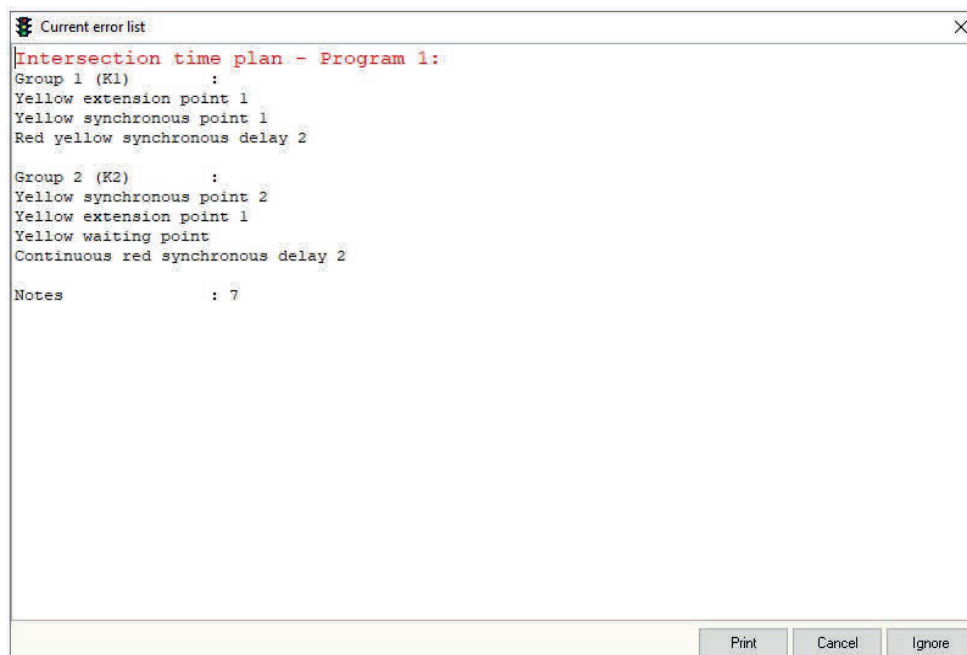

The system checks whether there is an error in the following functions for red-yellow or yellow:

- Extension points
- Waiting points (manual lock-in points)
- Synchronous points

3.1.4 Automatic program check

There is also an automatic program check that checks all released programs for errors or invalid entries.

As soon as errors are found, an error list opens and the menu structure also opens out.

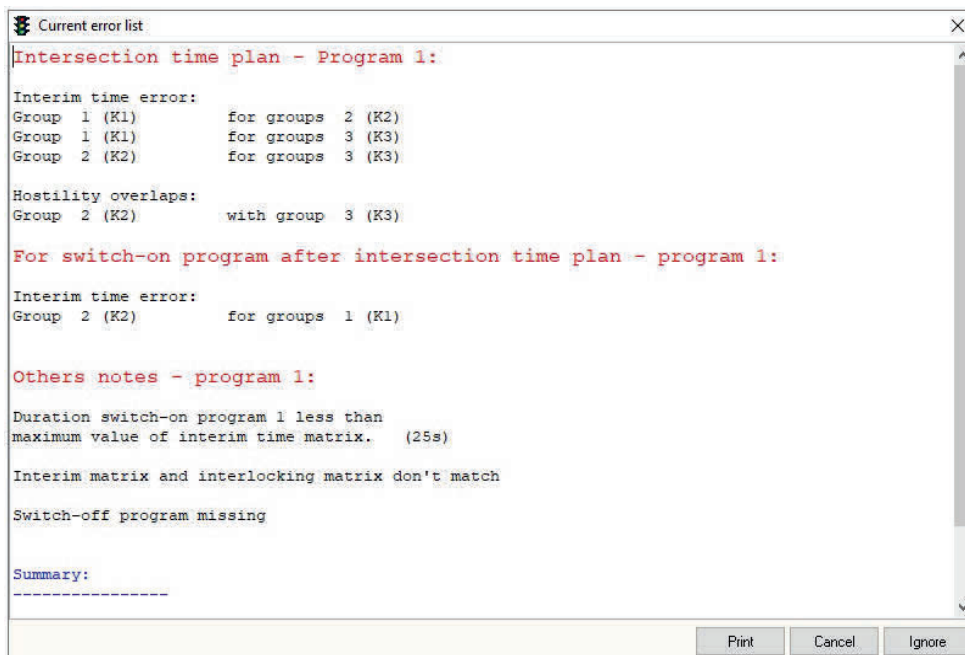

The program data are checked for the following errors:

- Interim time errors, overlaps in the intersection time plans and in the switch-on and switch-off programs
- Interim time errors in the transition from switch-on program to intersection time plan
- Interim time errors in the transition from intersection time plan to switch-off program
- Duration of switch-on program as per RiLSA
- Matching of interim time matrix and locking matrix
- Blanking programmed
- Whether data exist for all released programs in the intersection time plans, switch-on and specific switch-off programs
- Overlaps red-yellow + yellow against green in intersection time plan
- Compliance with minimum release times
- Red lamp monitoring disabled for green arrow

Note:

The automatic program check is always carried out on selecting one of the following functions:

- Load program, save program, save program as or import program
- Transfer data to controller or import data

3.1.5 Error messages

Error messages appear when entries are not made correctly in the individual windows. If an error message appears in a window, this cannot be closed until the faulty entry has been corrected.

3.1.6 Copy functions

The masks that appear to make entries for various programs have a choice of various copy functions. The possible choices differ, depending on the mask. The selected data are deleted depending on the confirmation.

Note:

Only the released programs are shown as target programs.

3.1.7 Delete functions

The possible choices for the delete function differ, depending on the mask. When selected, a query appears, asking what should be deleted (group, tab, whole program, etc.). The selected data are deleted depending on the confirmation.

Note:

If you select **Delete all** or **All programs**, all data of the current entry mask are deleted also including data of the not released programs.

3.1.8 OK button

If you click on **OK** in an open mask, the displayed data are saved in this mask.

Note:

If an entry mask is closed with X or with the system menu, the following query always appears:

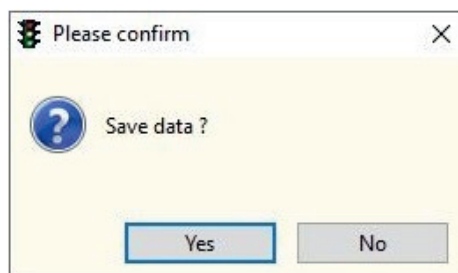

Confirm with **Yes** to save the data in the respective mask. If you click on **No**, no data are saved and the data already existing when the mask was opened remain.

3.1.9 Cancel button

If you select **Cancel** in an open mask, any data entered or changed in this mask are not saved.

3.1.10 User code

Every user of the software is given a user code. The code is needed for the following functions

- Program the controller
- Import the current program from the controller
- Switch monitoring
- Change parameters online (only EPB 12 / EPB 24 / EPB 48)

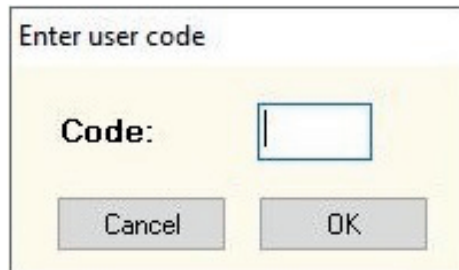

In the display outputs and switch monitoring masks, a number appears after the user box. This number indicates the user for whom the controller has been released.

Note:

The allocated user code is customer-dependent, not controller-dependent.

3.1.11 Keyword

A keyword has to be entered to select some menu points. The required function is only enabled after entering the right keyword. The corresponding keywords are available on request.



3.1.12 Data transfer between PC and controller

If on selecting a function that needs a connection between the PC and the controller and this connection does not work, a corresponding error message appears.



Possible reasons:

- No interface available
- PC lead not connected or incorrectly connected
- Wrong controller type / version entered
- Controller / interface not switched on
- 12 groups interface connected directly to PC (printer port) without PC lead

3.1.13 Automatic copy function

If there are several active programs and only one interim time matrix or locking matrix has been entered, the missing data are automatically copied to the corresponding masks of the program during transfer to the controller.

Note:

Automatic copying for the interim time matrix and locking matrix is only carried out if the special function Separate entries per program has been enabled. It is always the data entered in program 1 that are copied. If there are no data in program 1, then the empty masks are copied. On importing a program from the controller, the corresponding values appear in the masks again.

3.1.14 Menu bar in editors

Masks that are larger than the main mask also have a menu bar at the top of the mask. The entries in this menu bar correspond to the respective buttons at the bottom of the editor.

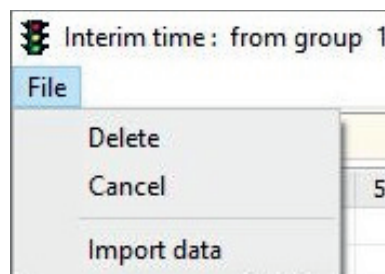

4. Main window

4.1 Basic supply

The basic parameters for the current program are entered in the main window.

4.1.1 Interim times

Switches between calculating and manual entry of the interim times. The corresponding functions are released in the menu structure depending on the selection. [☞ 6.2](#)

4.1.1.1 Calculate interim times with vehicle lengths

When calculating the interim times, use this selection box to enable calculation with vehicle lengths.

If this option is enabled, RiLSA defaults are preset in the signal group master data and the following message appears:

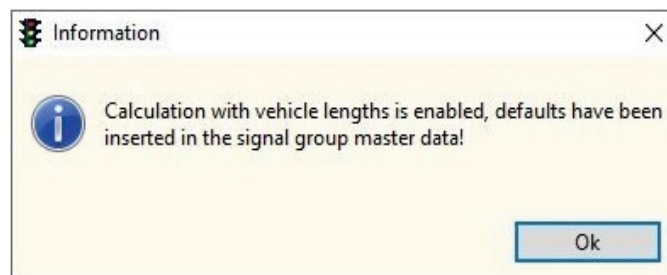

The following message appears if interim times had already been calculated:

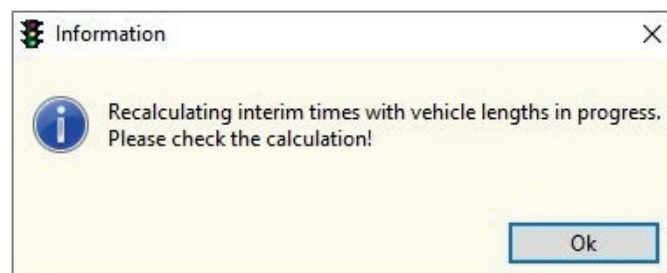

Confirm with **Yes** to recalculate all existing interim time calculations.

Note:

According to RiLSA, calculation with vehicle lengths is necessary for situations with crossing traffic flows, e.g. pedestrian crossings, T-junctions.

4.1.1.2 Calculate interim times without vehicle lengths

If this function is disabled, all interim calculations without vehicle lengths are recalculated and the following message appears:

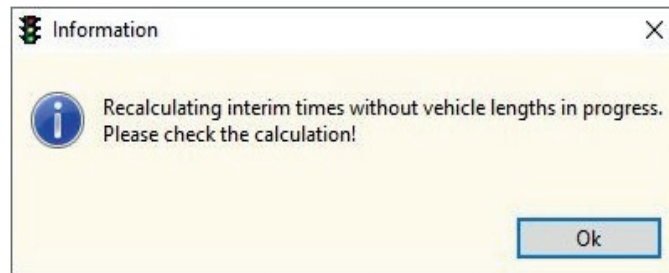

4.1.1.3 Enter interim times manually

If this function is enabled, the calculation functions are blocked. The interim times are then entered manually in the interim time matrix. [☞ 6.2.3.2](#)

4.1.2 Operating mode

The required operating mode of the controller can be selected here.

4.1.2.1 Fixed time mode with VA

In the operating mode fixed time with vehicle actuation, all green phases are entered "from ... to" within a cycle time. Depending on the controller type, two start-ups per cycle are possible. In this mode, various functions are possible, such as extension, request mode, progressive signalling, etc.

4.1.2.2 Phase transitions

The phase transitions mode is currently not yet available.

4.1.3 Interfaces

Default for the controller and printer interface:

A message appears if an interface is selected that does not exist or is already used by another application. If this is confirmed with **OK**, the default for the corresponding choice of interface is set to **None**.

Note:

When using USB/serial converters, these must always be connected before starting the software. The system ascertains all available interfaces on starting the software. USB/serial converters plugged in at a later point in time are no longer detected.

4.1.3.1 Controller interface

Selects the interface for data exchange between PC program and controller.

4.1.3.2 Interface for CPU protocol

Selects the required interface for the functions under **CPU protocol**. This is only available if the corresponding additional module has been activated.

4.1.4 Controller type

Used to select the required controller type. Depending on the selection, it may also be possible to select a version. There is also another selection possibility in addition to the supported controller types:

Program planning only. If this is selected, program planning is possible without being limited to the controller functions (e.g. more than 24 groups). The menu structure changes according to the selection.

4.1.5 General data

The number of groups, the location and the customer of the current program. It is also possible to enter a construction number.

These details then appear on every subsequent printout.

The number of groups entered here refers to the number of active and monitored groups.

Note:

If individual groups among the active groups have been omitted (because not supplied), status error messages of the omitted groups are still evaluated. Exception EPB 12 / EPB 24 / EPB 48: for these controller types, every monitoring function can be managed separately for every group,

4.1.6 Released programs

Shows the released programs and the adjusted emergency program. Depending on the selected controller type (EPB 12 / EPB 24 / EPB 48), the adjusted start and manual program is also shown.

This setting can be changed in the basic data menu point in the program release submenu.

☞ 6.1.7

4.2 Toolbox

Offers direct access to the most important main functions (from left to right): new program, load data, save data, save data as, send data to controller, receive data from controller, show outputs, switch monitoring functions.



4.2.1 New program

Click here to delete all entered data or reset them to the defaults and close the menu structure. If data have been entered or changed, a query appears whether they should be saved. The default controller type is EPB 24, version 7.1x.

4.2.2 Load data

Click here to open the following dialogue for loading program data.

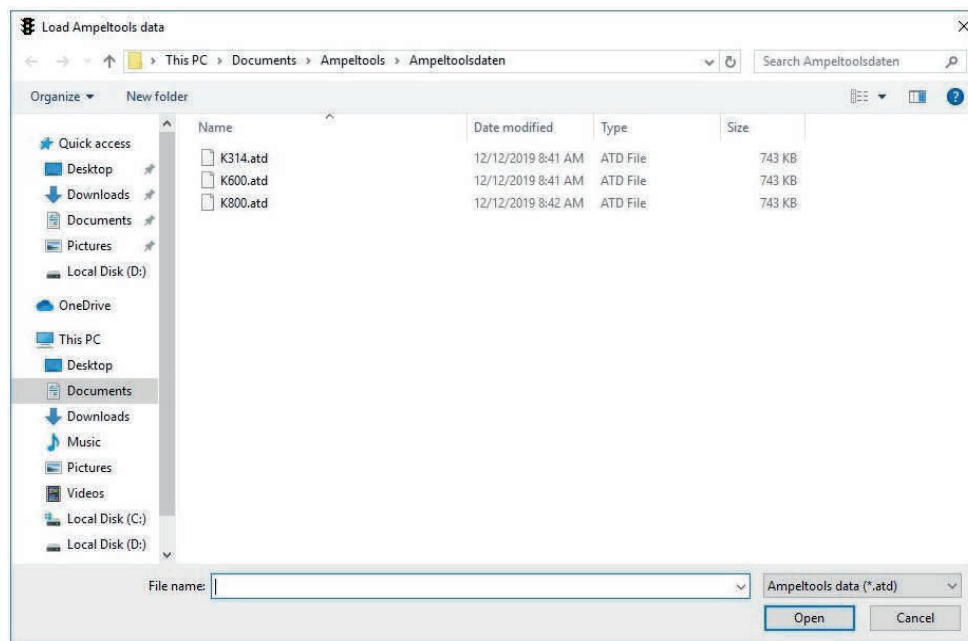

Select the required file with the left mouse button. Click on **Open** to load the data.

A progress bar appears in the main window.

When loading the data for Ampeltools, additional files are also loaded. If one of these files is missing, a corresponding error message appears.

Possibly missing files:

- File name with the suffix TXT (program comment)

4.2.3 Save data

If no file name is entered, the function Save as appears, [4.2.4](#)

If the file name already exists, a query appears whether these data should be overwritten.



Confirm with **Yes** to overwrite the data.

4.2.4 Save data as

Click here to open the dialogue for saving the current program data. Only use this dialogue if no file name has been given yet. If data exist, the function Save data appears.

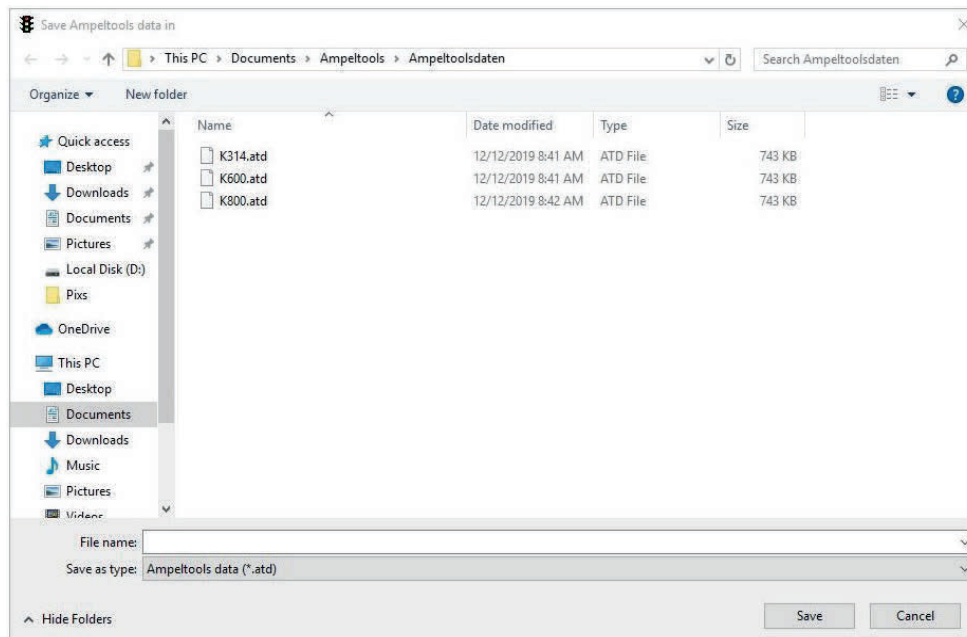

Enter the name for saving the project in the box **File name**.
A progress bar appears in the main window.

4.2.5 Send data to controller

Click on Send data to see a window where a user code has to be entered.
Enter the user code in the corresponding box. This may also be automatically preset, depending on the default in the program settings. [☞ 2.4](#)
When entered correctly, the current data are then sent to the controller.

Note:

There is no query of the user code for MPB 4xxx, [☞ 4.2.7](#)



Entry of the user code is concealed, with only a hash (#) appearing for every entry.
Incorrect entry triggers the message **Unauthorised access** and the program waits for the correct entry to be made.

If no connection lead is plugged in, a corresponding error message appears.

After entering the right code, the text on the button **Code** changes to **Start**. The data are sent to the controller as soon as you press **Start**.

If the overprogramming function is enabled [☞ 4.2.5.1](#), once the user code has been entered the system checks whether overprogramming is possible.

The following conditions must be fulfilled for overprogramming:

- The number of active groups or power cards must not change
- No groups in continuous green or continuous yellow. Flashing is allowed
- Controller not set to blank or flashing

Note:

If overprogramming is not possible in the currently running day program, the controller changes automatically to the smallest released program (if present) in which overprogramming is possible.

When overprogramming is completed, the controller changes back to the defined program.

[☞ 4.2.5.1](#)

This function is supported from CPU version 7.00.

Overprogramming is not possible if one of these conditions is not fulfilled. The following query appears:

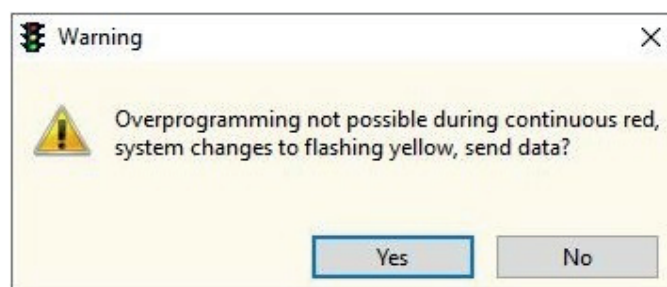

If you confirm this query with **Yes**, data are sent to the controller. But this then switches to yellow flashing, as announced in the query. If **No**, the process is cancelled.
If overprogramming is possible, this is shown in the controller display.

The following window appears in the PC program:



The controller automatically switches all groups to red. No more extensions or program changes etc. are carried out so that continuous red is achieved as soon as possible. Data transfer begins on achieving continuous red. During data transfer, a progress bar shows the status of data transfer and the number of transferred records. Up to 516 data records are transferred, depending on controller type and version. When data transfer has finished, the greyed out **OK** button becomes visible, together with the word **ready**.

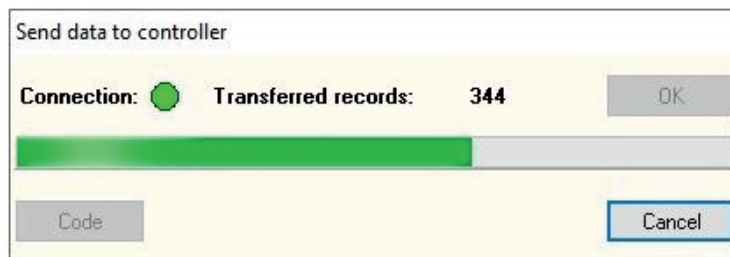

Click on **OK** to close the window.

If you try to transfer a program to the controller with more active groups than can be processed, the error message **Unacceptable programming** appears.

In addition to the data, the displayed program name is also transferred to the controller during programming.

If data transfer is cancelled prematurely or interrupted, data will be lost for security reasons. A corresponding display appears (EPB 12 / EPB 24 / EPB 48), or the Programming active lamp flashes.

This prevents the controller from carrying out a program that has not been transferred correctly. Data transfer now has to be done again.

4.2.5.1 Overprogramming

This function is only carried out by controller types EPB 12 / EPB 24 / EPB 48. If overprogramming is activated in the program settings, an overprogramming query appears when you try to save data and send data to the controller.

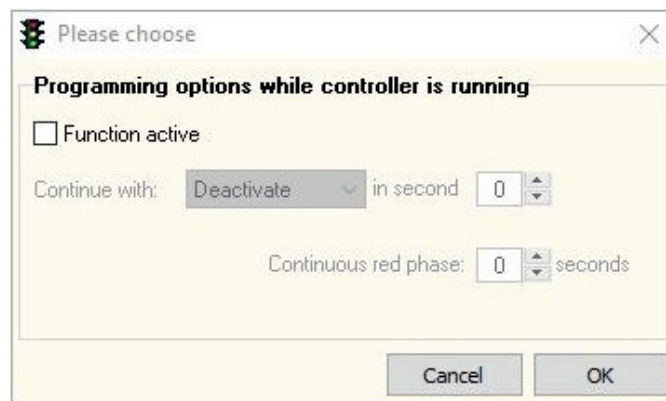

The screenshot shows a dialog box titled "Please choose" with a close button (X) in the top right corner. The main heading is "Programming options while controller is running". Below this heading, there is a checkbox labeled "Function active" which is currently unchecked. Underneath, there is a label "Continue with:" followed by a dropdown menu showing "Deactivate", the text "in second", and a numeric spinner box set to "0". Below that, there is a label "Continuous red phase:" followed by another numeric spinner box set to "0" and the word "seconds". At the bottom of the dialog, there are two buttons: "Cancel" and "OK".

If the function is not activated, during programming the controller switches to yellow flashing, according to the last programming.

If the function is active, the controller automatically switches all groups to continuous red. Data transfer to the controller begins when this status is achieved.

When programming is done, the controller checks whether the entered continuous red phase has already expired. If not, the controller remains in continuous red for the remaining time, which appears in the controller display.

If the entered continuous red phase has expired, the controller continues with the program sequence according to the preset program and seconds.

If another day program is active, the program is changed on reaching the GSP.

If another program is active at this point, the program is changed on reaching the best/common switching point (GSP).

If this function is activated, the corresponding entry possibilities are enabled.

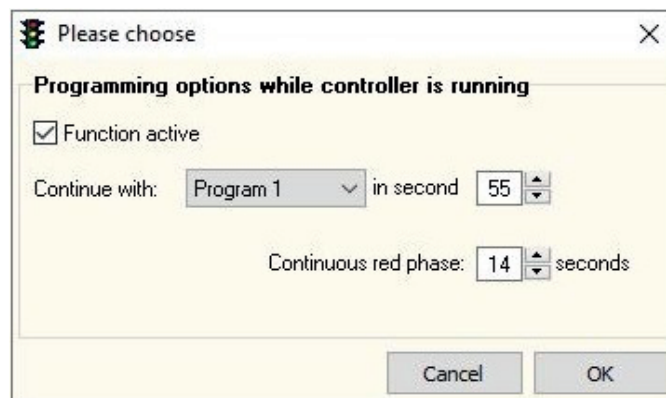

The screenshot shows the same "Please choose" dialog box as above, but with the "Function active" checkbox checked. The "Continue with:" dropdown menu now shows "Program 1", the "in second" text is present, and the numeric spinner box is set to "55". The "Continuous red phase:" spinner box is now set to "14" seconds. The "Cancel" and "OK" buttons remain at the bottom.

At **Continue with**, select the program (depending on program release) with which the controller should continue its program sequence after overprogramming. At **second**, enter the second in which this should happen.

When overprogramming has finished, use the **Continuous red phase** box to enter the total time for which the controller must remain in continuous red. This complies with any possible increased interim times.

The default is the highest value entered in the interim times matrix. If this is empty, the default is 99.

Note:

When selecting the seconds, please take care not to generate any impermissible colour sequences. The controller starts the program in the entered second.

If the function is active or a program is loaded in which this function has been activated, the current data appear on opening the mask.

4.2.6 Receive data from controller

A user code needs to be entered, as for sending data to the controller. This is automatically preset, depending on the default in the program settings. ↗ 2.4
When entered correctly, the current data are then transferred from the controller to the PC.

Note:

There is no query of the user code for MPB 4xxx. ↗ 4.2.7



During data transfer, a progress bar shows the number of records and the status of data transfer. Depending on controller type and version, the number of transferred records can be up to 399. Press Cancel to cancel the active data transfer. If no connection lead is plugged in, a corresponding error message appears. When data transfer has finished, the **Code** button is followed by the message that the data have been read, stating the name of the corresponding program. The received program name also appears in the main window header.



Note:

Programs in the VA mode are not supported by this software. Programs in this mode cannot read and processed with Ampelwin.

4.2.7 Data transfer between PC, MPB 4xxx and 12 groups interface

This function needs the 12 groups interface. This is used for data transfer between the PC and the hand box or traffic light 1 (MPB 4000 / 4400). Depending on the program function, (special mask **Program change on request**), it is necessary to use an interface with version from 6.00, a hand box from version 18:59 and for traffic light 1 at least version N1001 10:00.

Note:

The 4 groups interface cannot be used for this purpose as it is used only for exporting and printing the hand box data.

4.2.7.1 Send data to interface

Switch interface on as long as **Next / Previous** appears, then press **4** until **Data exchange with PC F1/F2** appears. Data can now be sent to the interface.
A message appears on the display when data transfer has finished.

4.2.7.2 Receive data from interface

Switch interface on as long as **Next / Previous** appears, then press **4** until **Data exchange with PC F1/F2** appears. Data can now be received from to the interface.

4.2.7.3 Send data to MPB 4xxx

Switch interface on as long as **Next / Previous** appears, then press **4** until **Online mode/F2** appears, then adjust the menu point. The data can now be sent directly to MPB 4xxx.

Note:

In this mode, the interface is only used for data transfer. Existing program data are not changed.

4.2.7.4 Receive data from MPB 4xxx

Switch interface on as long as **Next / Previous** appears, then press **4** until **Online mode F1/F2**. Data can now be received directly from MPB 4xxx.

Note:

In this mode, the interface is only used for data transfer. Existing program data are not changed.

4.2.7.5 Send data to hand box

Switch interface on. As long as **Next / Previous** appears, press **4** until **Online mode F1/F2** appears. Switch the hand box on. **Continue with 4** appears. If there is a PC program in the hand box, press and hold **2** until **Expect data from PC** appears.
If the hand box is in entry mode, hold and press **4** until **Expect data from PC** appears.
Then place both devices on top of each other with the windows facing (back of the device). The data can now be sent directly to the hand box.

Note:

It is not possible to receive data from the hand box!

4.2.7.6 Send data to interface MPB 44 M

Switch terminal on, select interface type **PC** and wait for the interface program to start. Press and hold **4** until **Data exchange with PC** appears.
Data can now be sent to the interface.
A message appears on the display when data transfer has finished.

4.2.7.7 Receive data from interface MPB 44 M

Switch terminal on, select interface type **PC** and wait for the interface program to start.
Press and hold **4** until **Data exchange with PC** appears.
Data can now be received from to the interface.

4.2.7.8 Send data to MPB 44 M

Switch terminal on, select interface type **PC** and wait for the interface program to start.
Press and hold **4** until **Online mode** appears.
Data can now be sent directly to MPB 44 M.

Note:

In this mode, the interface is only used for data transfer. Existing program data are not changed.

4.2.7.9 Receive data from MPB 44 M

Switch terminal on, select interface type **PC** and wait for the interface program to start.
Press and hold **4** until **Online mode** appears.
Data can now be received directly from MPB 44 M.

Note:

In this mode, the interface is only used for data transfer. Existing program data are not changed.

4.2.8 Emergency controller EPB 12 / EPB 24 / EPB 48

Calls up the **Emergency controller** function.  5.1

4.2.9 Show outputs

Click here to open a window that shows current data from the controller and the radio clock.
The header shows the interface being used and the name of the active program in the controller.

Note:

For EPB 12 / EPB 24 / EPB 48 (from version 6.60), the current data of the radio clock only appear in combination with radio clock V4. This function is not supported if a BCD clock is plugged in.

4.2.9.1 Show current controller data

When a connection exists, a rotating sign (*I*) appears in the connection box. If the connection is interrupted, transfer is finished and the window closes. A corresponding error message appears. The following information is shown: the currently active program, the cycle time and the actual second in the active program, date and time from the controller, active program name, file, test mode on or off, software version of the controller and the current user.

If faults occur, the groups causing the fault are shown. Similarly, requested groups or active detector inputs are shown.

For EPB 12 / EPB 24 / EPB 48 (from version 6.60), the active sync. inputs for progressive signalling are also shown:

The following sync. inputs are shown:

- Sync. 1 and 2 - terminal strip inputs
- Sync. radio clock - radio clock input
- Sync. serial 1 + 2 - information in serial message

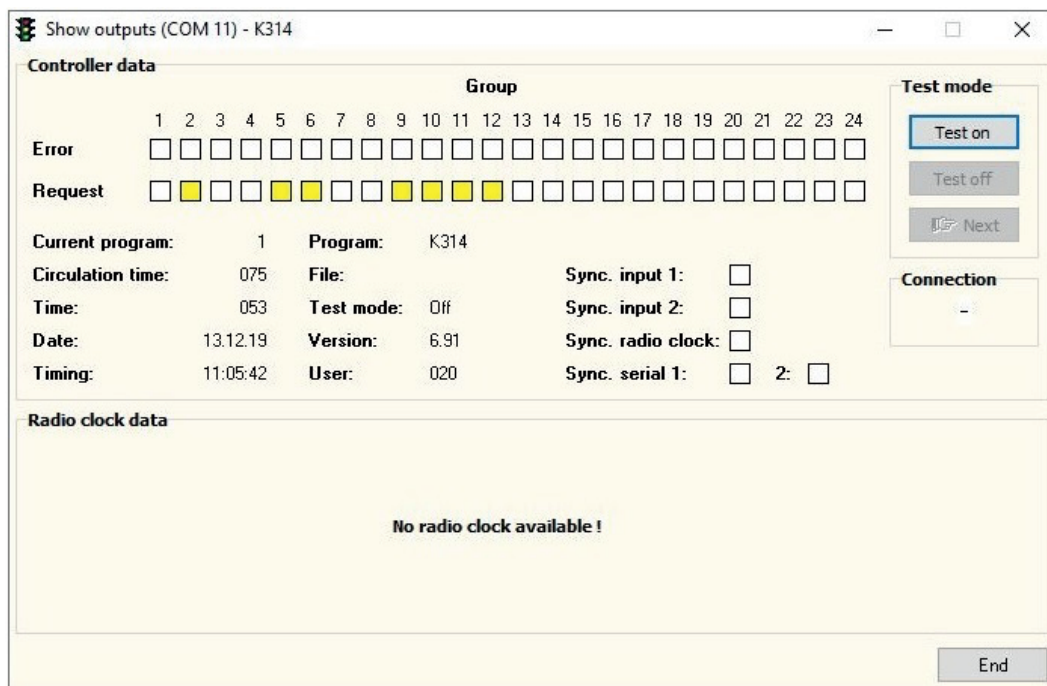

If a group is requested, this is indicated in yellow for the corresponding group.

If a group is at green and the corresponding detector input is in use, yellow is also indicated for this time.

If an error has caused a shutdown, the group triggering the error is indicated in red. For green/green or interim time errors, red then appears for the affected groups.

4.2.9.1.1 Test mode

If you click on **Test on**, you will be asked for a keyword (available on request).
 When entered correctly, the test mode is switched on and the controller stops immediately in the current program!
 Click on **Continue** to continue the program second by second.
 Click on **Test off** to switch the test mode off again.
 The text mode is switched off immediately if the PC-controller connection is interrupted or if you click on **End**.

Note:

The test mode should only be used for testing in the workshop.

4.2.9.2 Show current radio clock data

As soon as a type V4 radio clock is detected in the controller, the corresponding data appear in the mask.
 The following information from the radio clock appears: cycle time, actual second, radio clock date and time, mode, clock status, reception strength, radio clock software version, current public holiday (if activated), current back calculation, output sync. point 1 + 2, summer or winter time active, radio clock IP address, status of the DHCP server.
 If the DHCP server is activated, **DHCP** appears after the radio clock IP address.

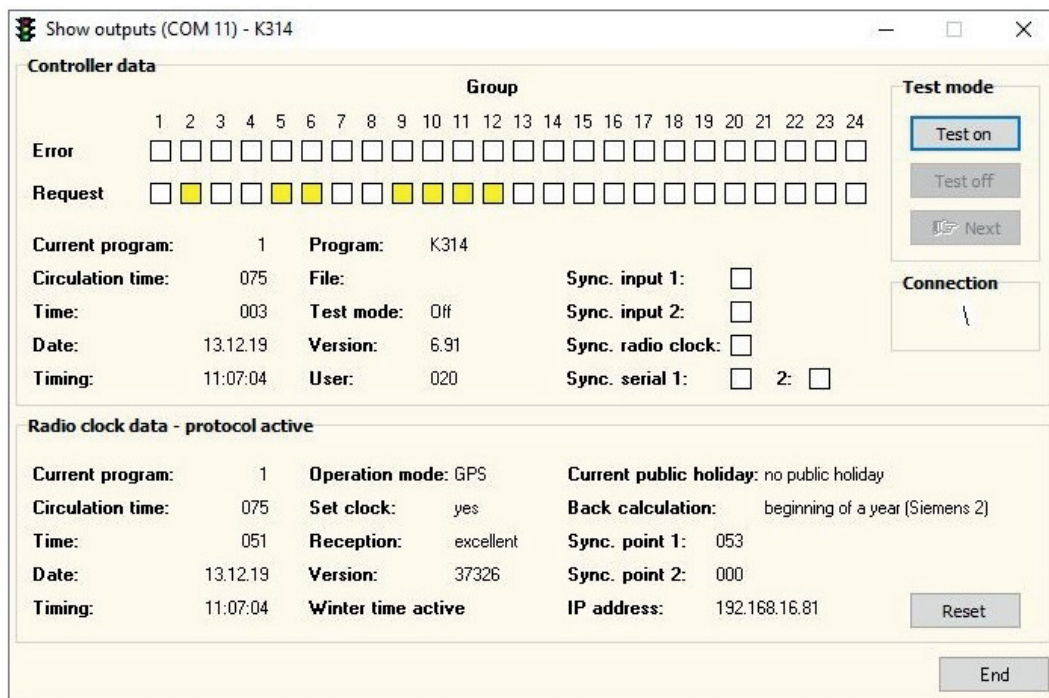

Note:

If a public holiday is found, this is shown as red plain text. If the current public holiday in the **Extended weekly automatic function** is used, this is shown as green text.

There can be various reasons why no radio clock data appear. The following text then appears under **Radio clock data**:

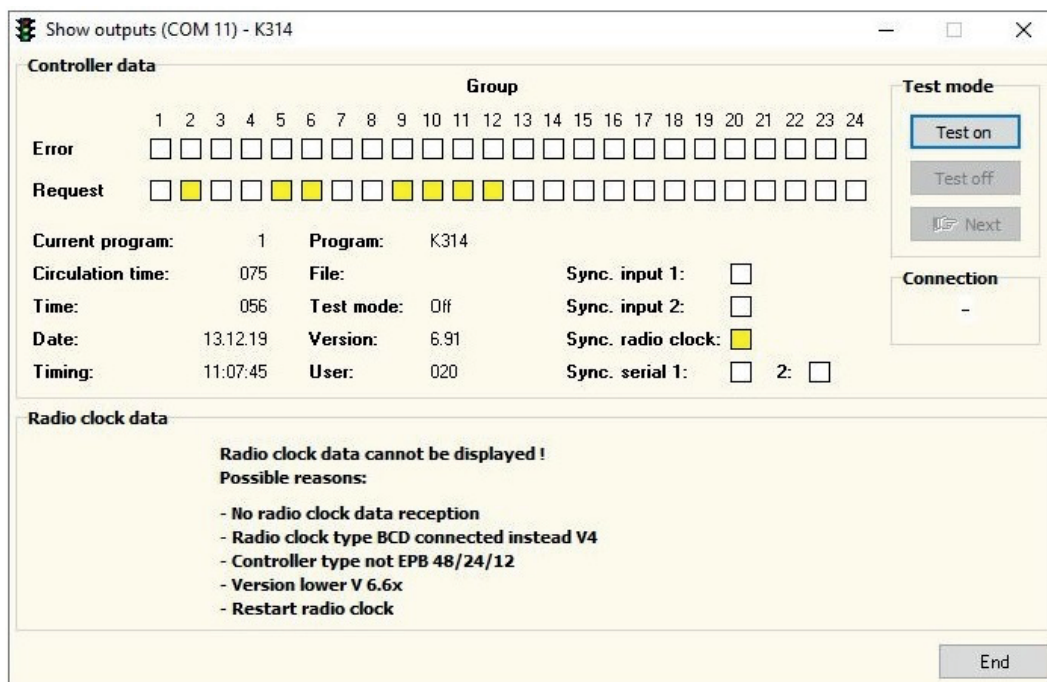

Possible reasons:

- No data connection from radio clock to CPU
- Wrong radio clock connected (type BCD)
- Wrong controller type connected (not EPB 12 / EPB 24 / EPB 48)
- Controller version not supported (lower than V 6.6x)
- Restart radio clock

4.2.9.3 Change radio clock IP address

Double click the left mouse button on the displayed IP address of the radio clock to open the following window with the current radio clock network settings:

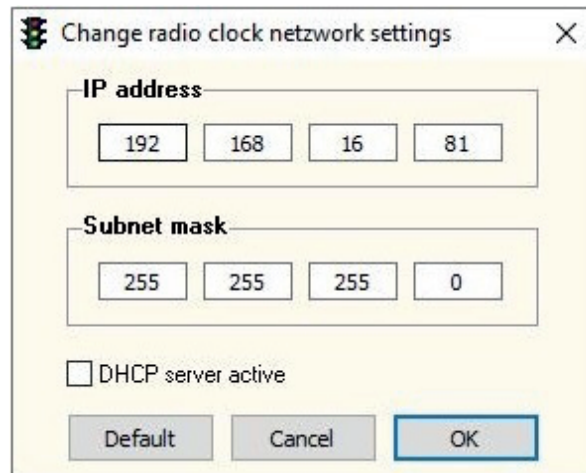

The screenshot shows a dialog box titled "Change radio clock network settings". It features a close button (X) in the top right corner. The "IP address" section contains four input fields with the values 192, 168, 16, and 81. The "Subnet mask" section contains four input fields with the values 255, 255, 255, and 0. Below these sections is a checkbox labeled "DHCP server active" which is currently unchecked. At the bottom of the dialog are three buttons: "Default", "Cancel", and "OK".

In this window, you can change the network settings and switch the DHCP server on or off. To change the IP address, simply enter the corresponding values. Select **Default** to adjust the factory settings: a corresponding query appears. If you close with **OK**, you will be asked to confirm whether the radio clock network settings are to be changed: depending on your confirmation, this is then carried out.

4.2.9.4 DHCP server

The DHCP server is switched on or off by ticking the corresponding checkbox. An active DHCP server allocates an IP address to directly connected computers (laptop / PC) so that both devices are in the same network. Alternatively, the DHCP server can also be switched on or off from the controller keyboard (EPB48 / 12 from version 6.70).

Note:

The DHCP server should not be switched on when the radio clock is connected to a network that already has a DHCP server. Several DHCP servers in a network can cause mutual interference when allocating the IP address.

4.2.9.5 Reset radio clock

Select **Reset** to reset the radio clock: a corresponding query appears.

Note:

When resetting the radio clock, the connection to the radio clock is interrupted and no current radio clock data are shown. These appear again as soon as the reset is finished.

4.2.10 Switch monitoring

When you select Switch monitoring, you will be asked for the user code. If it agrees with the user code in the controller, a window opens to switch monitoring. The header shows the interface being used and the name of the active program in the controller. As in the **Display outputs** mask, some current data from the controller appear here too. There are also various options for switching the monitoring.

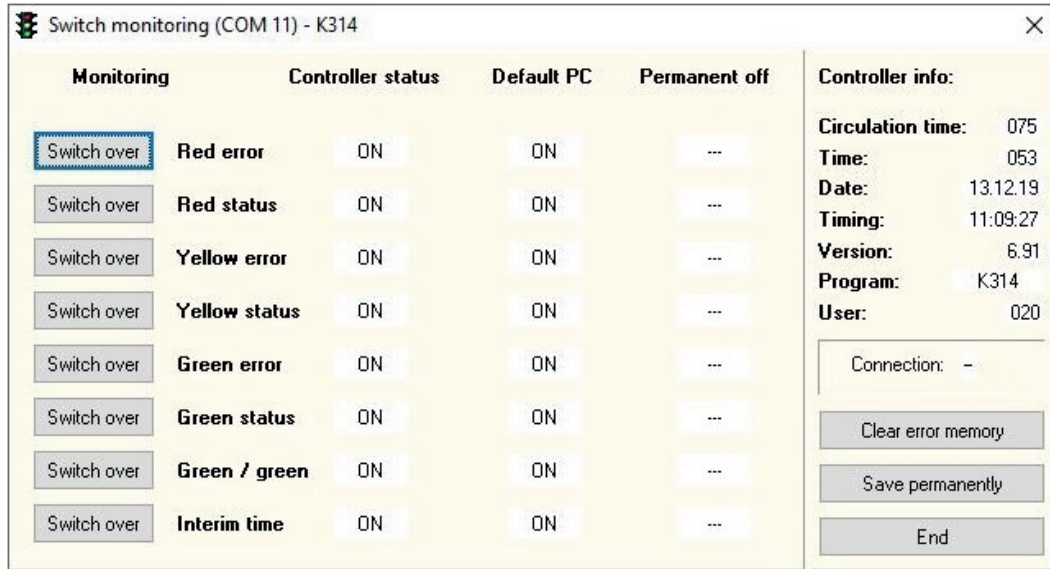

When you open the mask, the condition of the individual monitoring functions appears below **Controller status**.

The data appear approx. one second after the mask is opened (because they have to be transferred from the controller first).

Every time the mask is re-opened, the **Default PC** is preset to **ON**.

Exceptions:

Monitoring functions that are permanently off. The default from the PC mask appears below **Default PC**. **Yes** appears under **Permanently off** for monitoring functions that are permanently switched off.

Click on A corresponding display appears on the screen for EPB 12 / EPB 24 / EPB 48, If a monitoring function is switched off, it remains disabled until one of the **Switch monitoring** or **Display outputs** masks is closed, or it is switched on again by clicking on **Switch over**.

If other monitoring functions are switched off, they are enabled again automatically after 10 minutes.

If the connection between PC and controller is interrupted, the respective monitoring functions are automatically enabled again after ten minutes.

In the event of a controller reset, all monitoring functions that had been switched off are automatically enabled again. Exception: monitoring functions that are permanently off.

4.2.10.1 Switch monitoring functions permanently off

Switching monitoring functions off permanently has to be done from the PC.

If you click on **Save permanently**, you will be asked for a keyword (available on request). When the keyword is entered correctly, all monitoring functions disabled at the PC are switched off permanently.

This is shown by **Yes** appearing under **Permanently off** for groups where the monitoring function has been permanently switched off.

If a monitoring function is switched on again at the PC, **Permanently off** is disabled again for the respective monitoring function.

Important note:

Permanently off monitoring functions are switched off for a defined time (30 to 60 minutes depending on the controller). This status remains even after the overall controller has been switched off.

Monitoring functions that are permanently off are enabled again when switched on at the PC, when the controller is reprogrammed or when the defined time has expired.

This function serves troubleshooting purposes and is not intended for permanent operation.

4.2.10.2 Clear error memory

The controller saves the last five current errors. They can be printed from the controller at any time. To produce the printout, click on Print error report (or use the print menu for EPB 12 / EPB 24 / EPB 48).

To clear the error memory after testing the monitoring functions (e.g. in the workshop), go to the Monitoring functions mask and click on **Clear error memory**.

A confirmation query appears.

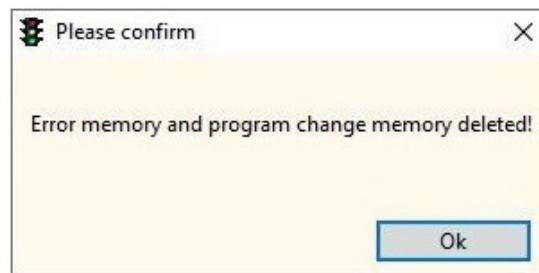

There is then no longer any information in the error memory.

4.2.10.3 Clear program change memory

In controller EPB 12 / EPB 24 / EPB 48, the program change memory is cleared automatically on clearing the error memory.
Other controllers do not have this function.

4.2.11 CPU simulation

Calls up CPU simulation. ↗ 7.1

4.2.12 CPU protocol

Calls up CPU protocol. ↗ 8.1

4.2.13 Printing data from controller

Calls up CPU printing data from controller. ↗ 8.3

4.2.14 Configuration local public transport module

Calls up configuration local public transport module. ↗ 10.1

4.3 Menu structure

The menu structure lists all entry masks for the program data and settings etc. for selection. The structure varies depending on the selected controller type and version.

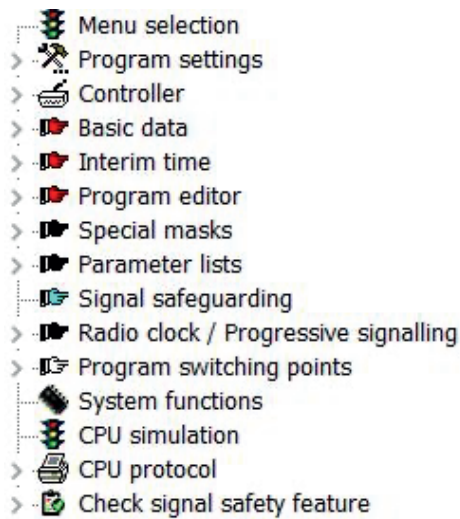

Note:

Some menu points are disabled if the controller interface settings are set to **None**.

Click the right mouse button in the menu structure to see a selection menu with the following content:

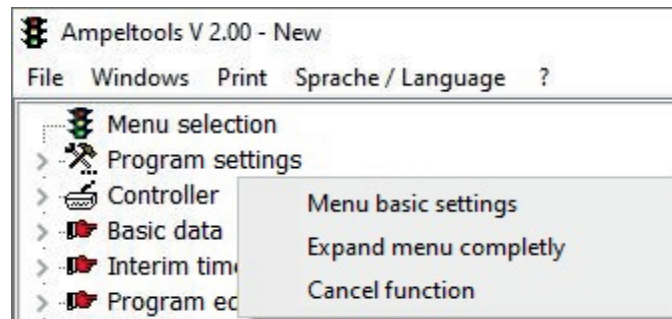

















- **Menu basic settings**
If selected, the complete menu structure is closed
- **Expand menu completely**
Opens the expanded view of the whole menu structure with all sub-points
- **Cancel function**
Closes this selection menu

Note:

The menu structure is always closed on loading or importing data and when the controller type/version is changed.

4.3.1 Menu structure symbols

The symbols in the menu structure change according to data input progress. The following symbols are used for main points and sub-points:

Description menu symbols	
Icon	Use
	Error interim time, green/green present in a sub-point
	Error interim time, green/green in corresponding input mask
	Menu point blocked
	Faulty input present in a sub-point
	Faulty input in corresponding input mask
	Necessary data missing in a sub-point
	Necessary data missing in input mask
	Defaults in a sub-point that may need editing
	Defaults in input mask that may need editing
	Defaults in sub-points
	Defaults in corresponding input mask
	Necessary data present in all sub-points
	Data present in input mask or not defaults
	Data edited in monitoring mask
	No data present in sub-points
	No data present in input mask
	Input mask opened

Note:

Error symbols always take priority over other symbols. Some menu points have fixed symbols, these are not described especially.

4.3.2 Program settings

Opens a sub-menu where all settings can be adjusted for this software.  2.1

4.3.3 Controller

Opens a sub-menu with all functions for data exchange between the PC program and the controller.  5.1

4.3.4 Basic data

Opens a sub-menu for selecting various entry masks for the basic program data.  6.1

4.3.5 Interim times

Opens the interim times menu.  6.2

4.3.6 Program editor

Opens a sub-menu for selecting various entry masks for the program data.  6.3

4.3.7 Special masks

Opens the menu for selecting all special masks.  6.4

4.3.8 Parameter lists

Opens the menu for selecting the parameter lists

4.3.9 Number of signal heads

Opens the menu for entering the number of signal heads (only MPB 4xxx).  6.6

4.3.10 Signal safeguarding

Opens the editor for entering the monitoring functions (signal safeguarding).  6.7

4.3.11 Radio clock / Progressive signalling

Opens the sub-menu to adjust the functions for the radio clock / progressive signalling.  6.8

4.3.12 Program switching points

Open a selection menu to enter the switching times of the internal controller clock.  6.9

4.3.13 System functions

Opens an editor for entering the system functions.  6.10

4.3.14 CPU simulation

Starts the simulation function if the add-on module has been activated.  7.0

4.3.15 CPU protocol

Opens a menu with the CPU protocol functions if the add-on module has been activated. ↗ **8.0**

4.3.16 Check signal safeguarding

Opens a menu with the Check signal safeguarding functions if the add-on module has been activated. ↗ **9.0**

4.4 Menu bar

The menu bar includes functions that are used less frequently: the windows list, all print functions and a help menu.

4.4.1 File

4.4.1.1 New program

Opens the new program function. ↗ **4.2.1**

4.4.1.2 Load data

Opens the load program data function. ↗ **4.2.2**

4.4.1.3 Save data

Opens the save program data function. ↗ **4.2.3**

4.4.1.4 Save data as

Calls the save program data function. ↗ **4.2.4**

4.4.1.5 Save Ampelsim data

This function converts the current program data to the file format needed for the Ampelsim simulation program.

The following selection dialogue appears:

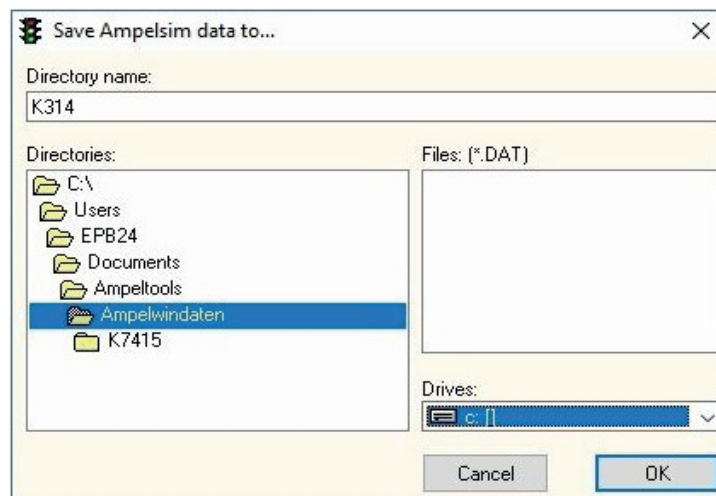

Enter the required program name in **Directory name**. If a program name already exists, it automatically appears as default. A directory with this name is created in the stated directory. The data of the current program are then saved in this directory.

Use the **Drives** and **Directories** options to change the directory for saving the data. The directory adjusted for the Ampelwin data appears as default.

If the required directory does not yet exist, you will be asked if you want to create it:

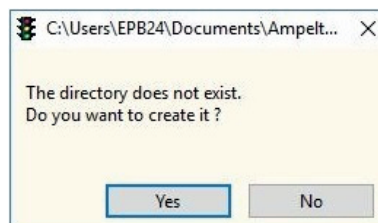

Confirm with **Yes** to save the data in the corresponding directory. The following confirmation window then appears:

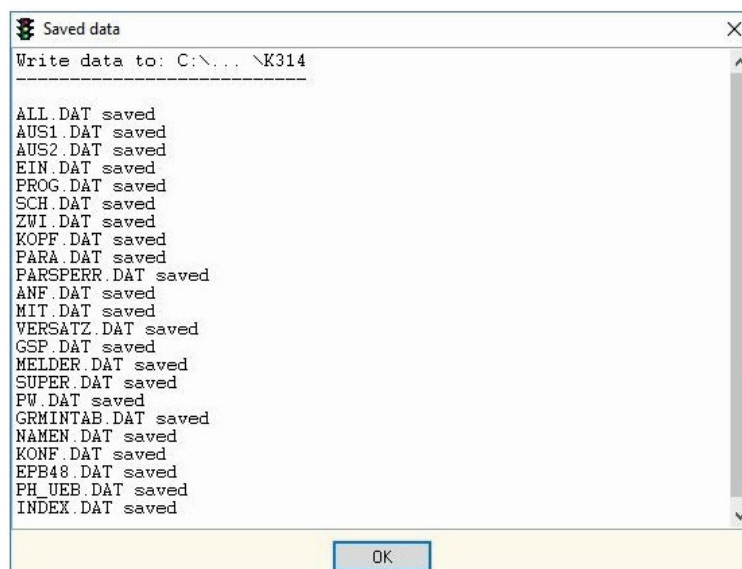

Notes:

- The function is not carried out if no data are available. A corresponding message appears.
- Free program planning data cannot be converted. Here again, a corresponding message appears:

4.4.1.6 Send data by email

Transfers the current program data to the standard email program.

The current program data have to be saved in the Ampeltools format so that they can be sent by email.

A message appears if the data have not been saved or changed.

Note:

The email function uses an internal Windows email interface which blocks the application until the email has been sent.

To send the program data manually, the files of the required project with the suffix .atd, and .txt must also be added.

4.4.1.7 End

Ends Ampeltools. If data have been entered or changed, a query appears whether they should be saved.

The adjusted interfaces, controller type and corresponding version are saved separately. The last setting appears next time the program begins.

4.4.2 Windows

The list of windows always shows all opened entry masks.

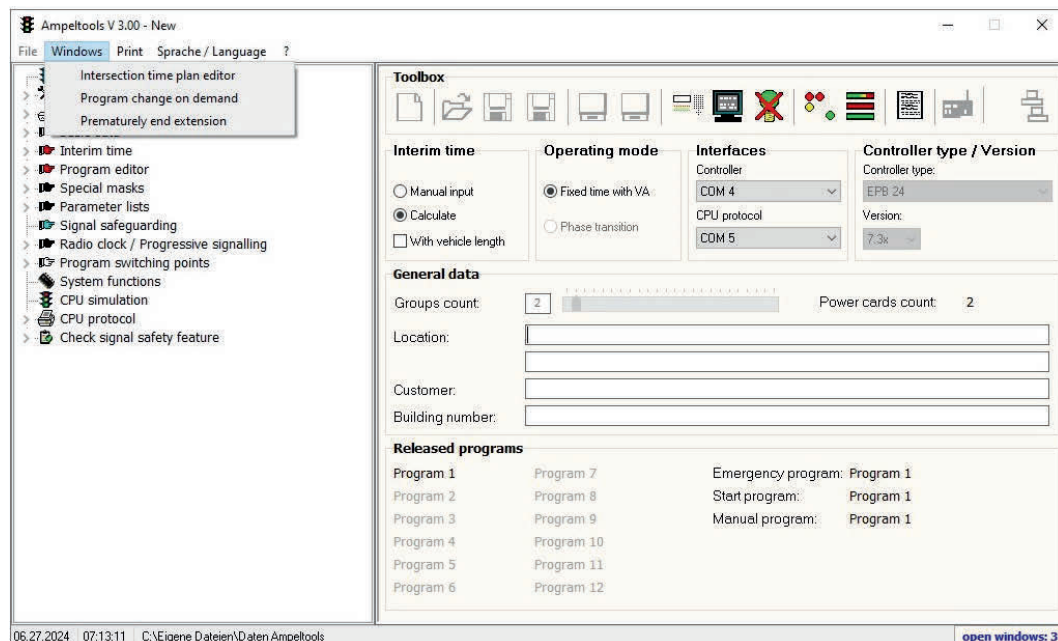

On selecting an entry in the list, the corresponding mask then appears in the foreground.

4.4.3 Print

All print functions can be selected here.
The following possibilities can be selected:

- In the PC data menu, all existing data can be printed. Each entry mask has its own print call-ups.
Select **Print all** to print the corresponding data in the default of the print settings. 📄 2.2
- Use **From controller** to print the data directly at a serial printer connected to the controller.
This function is only available if a free serial interface is available for sending the control commands.

4.4.3.1 Print PC data

The individual print functions can be selected in the **Print** menu. When a printout has been selected, the system checks whether print data are available for the print job.
If no data are available, the following error message appears:

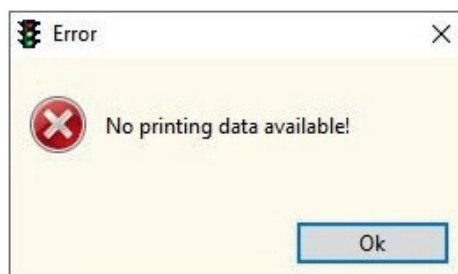

If the selected print data are available, a dialogue appears to select the printer, depending on the program setting. If this function was disabled, the standard printer prints the data straight away.

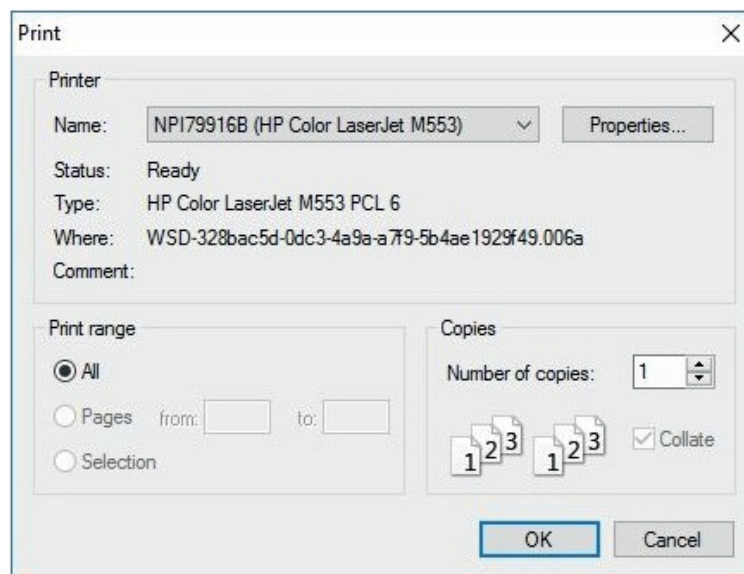

Click on **OK** to print the data.

Note:

Depending on the adjusted controller type, functions that are not supported will be disabled in the print masks.

4.4.3.1.1 Print basic data

General data applying to all programs are called up with a separate menu point. There are no sub-menus.

The following possibilities can be selected:

- Map
- Program comment
- Locking matrix
- Interim time calculation
- Switching points blank / flashing
- Switching points weekly automatic radio clock
- Signal safeguarding
- Number of signal heads (only MPB 4xxx)
- Radio clock / progressive signalling
- Controller functions
- Program release

4.4.3.1.2 Print program data

There are individual menus with sub-menus for printing these data. The data to be printed are selected in the sub-menus.

The following possibilities can be selected:

- Locking matrix with activated special function
- Interim times matrix with activated special function
- Automatic intersection time plan / calculating cycle times according to traffic volumes
- Intersection time plans
- Group data
- Switch-on programs
- Specific switch-off programs
- Error switch-off programs

4.4.3.1.3 Print special masks

A sub-menu appears: It can be used to print data for the following special masks (depending on controller type):

- Active groups
- Map request inputs
- Automatic detector memory
- Delete request presets
- Delete linked requests with green
- Program change on request
- End extension prematurely
- Continuous red / preemption
- Signal groups mapping list EPB 12
- Moved outputs

4.4.3.1.4 Produce individual max. intersection time plans

This function is used to produce individual intersection time plans for printing. The function is under Intersection time plans (Print PC data). The following mask appears:

1	2	3	4	5	6	7	8	9	10	11	12	13	14	15	16	17	18	19	20	21	22	23	24	25	26	27	28	29	30	31
<input checked="" type="checkbox"/>	<input checked="" type="checkbox"/>	<input checked="" type="checkbox"/>	<input checked="" type="checkbox"/>																											

Produce for program:

1 2 3 4 5 6 7 8 9 10 11 12

Print Delete Close

Select the signal groups whose extension points/extension times should not be included in producing the maximum intersection time plan. Use **Page heading** to enter the text that should appear as the heading on the printout.

Use **Produce for program**: to select the program for which the maximum intersection time plans are to be produced as a printout. Click on **Print** to send the maximum intersection time plans to the printer.

Note:

Print is enabled when at least one program is marked in the selection box, otherwise it is disabled.

4.4.3.1.5 Print all

Prints all data selected in the default of the print settings. **2.2.3**

4.4.3.1.6 Print current error list

Prints the current error list. A printer selection or print preview appears, depending on the program setting.

4.4.3.2 Print from controller

Print commands can be sent from the PC software to the controller. The printout then appears on a serial printer connected to the printer port of the CPU.

To send print commands to the controller, the corresponding controller type and version must be adjusted in the main window.

Note:

If continuous printing is enabled (actual printing, error report line by line and program change line by line), no other printout is possible.

If the printout consists only of hieroglyphs or illegible characters, then the baud rate adjusted for the printer does not match the CPU. **6.9.7**

From version 6.50, the baud rate adjusted for the CPU appears on the info page (page 2) in the controller display.

4.4.3.2.1 Single print

This function opens the following window:

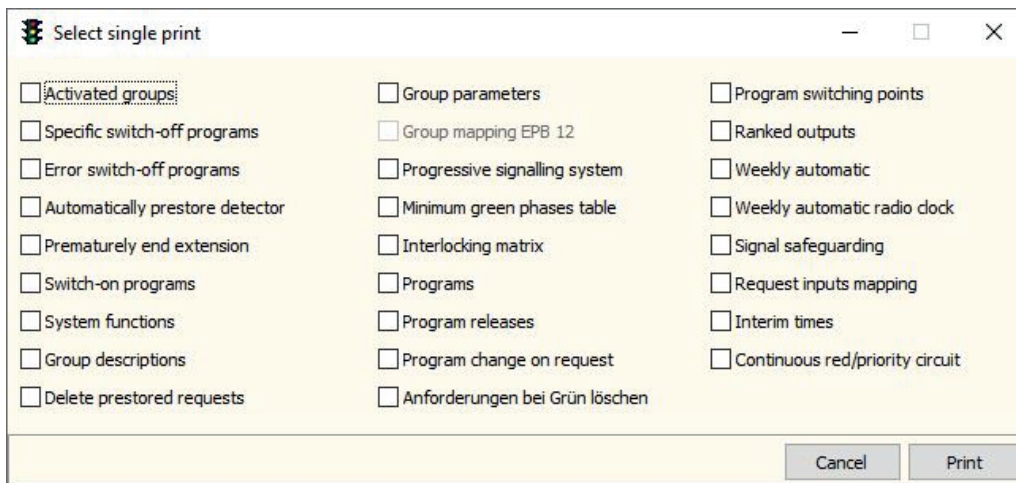

The required printouts can be selected in this window.
Click on **Print** to send the print commands to the controller.

Note:

The printout only refers to data from masks containing data.

4.4.3.2.2 Print NOM

Select **Print NOM** to print the nominal data for the following:

- Program values (green phases, yellow phases, time gaps, etc.)
- Interim times
- Locking matrix
- Minimum release times table
- Active groups (only EPB 12 / EPB 24 / EPB 48)
- Signal safeguarding

The other data are printed in the **Single print** menu.

4.4.3.2.3 Print error report line by line

Prints the error report from the controller, containing all current data (date, time, program, group etc.) at the time when an error occurred. Max. the last five errors are printed.

4.4.3.2.4 Print program change memory

Prints the last five program changes from the controller, containing all data about the time when a program change took place.

Note:

The functions for printing the program change memory are only carried out for controller types EPB 12 / EPB 24 / EPB 48.

4.4.3.2.5 Actual printing

Prints the actual intersection time plan from the controller, including the current signal statuses and the detector inputs at one-second intervals.

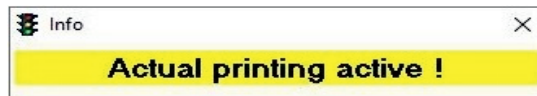

A message window appears as a check. This is closed automatically when actual printing is switched off again.

The **Print from control** menu then only shows **Actual printing OFF**, no other outputs are possible. Click on **Actual printing OFF** to end actual printing.

Note:

Actual printing ends automatically after 20 minutes.

The time can be adjusted from version 6.50 (only EPB 12 / EPB 24 / EPB 48).

4.4.3.2.6 Print error report line by line

Click on **Print error report line by line ON** for a line-by-line printout of the error report.

Every error is printed line by line; the header data are only printed once.

Every occurring error appears in its own line.

A message window appears as a check. This is closed automatically when **Print error report line by line on** is switched off again.

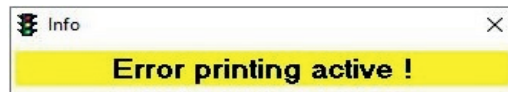

This kind of printout is used for example to test the monitoring functions, so that printing does not have to be started manually every time.

Click on **Print error report line by line OFF** to end line-by-line printing.

Note:

Line-by-line printing ends automatically after 20 minutes.

The time can be adjusted from version 6.50 (only EPB 12 / EPB 24 / EPB 48).

4.4.3.2.7 Print program change line by line

Click on **Print program change line by line On** to print the program changes line by line. Every program change is printed line by line. The header is only printed once and every occurring program change appears in its own line.

A message window appears as a check. This is closed automatically when **Print program change line by line ON** is switched off again.



This kind of printout is used for example to test the program change function, so that printing does not have to be started manually every time.

Click on **Print program change line by line OFF** to end line-by-line printing.

Note:

Line-by-line printing ends automatically after 20 minutes.

The time can be adjusted from version 6.50 (only EPB 12 / EPB 24 / EPB 48).

4.4.3.3 PC print setup

Opens a dialogue for selecting the standard printer to be used for subsequent printouts.

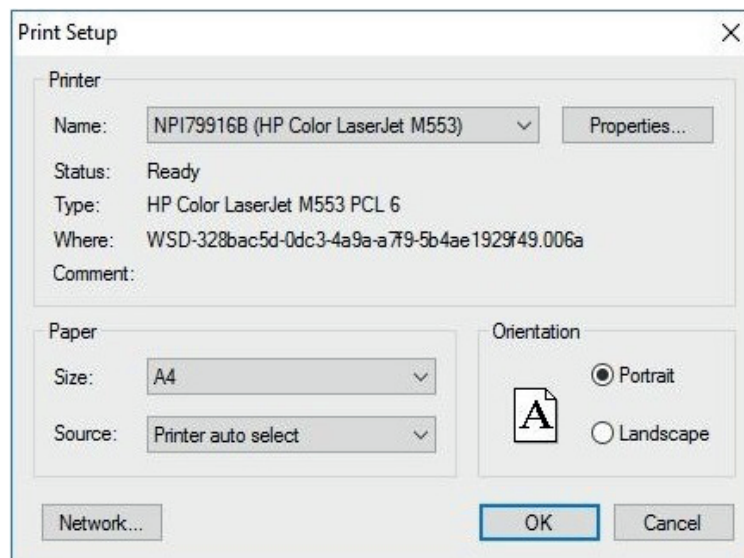

4.4.4 ?

4.4.4.1 User manual

Appears automatically if the user manual was installed during installation.

The user document can be accessed by pressing **F1** in every window: this document is then opened.

Note:

The user manual consists of a PDF document. The Acrobat Reader is needed to read it on the PC. This is available free of charge at <http://www.adobe.de>

4.4.4.2 Description of the menu symbols

This opens a description of the menu symbols.

4.4.4.3 Info

Opens a window with the current information.

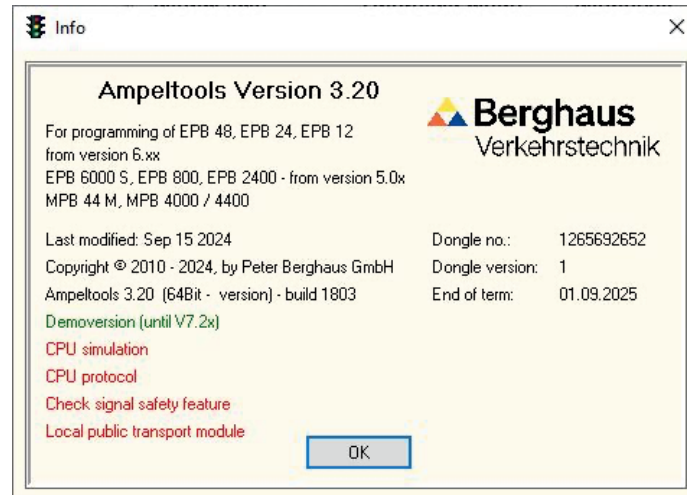

5. Controller

5.1 Emergency controller EPB 12 / EPB 24 / EPB 48

Opens the following mask showing the display, keyboard and signal groups display for the specific controller.

The signal group display (12 or 24 groups) changes depending on the adjusted controller type. If the adjusted controller type does not match the connected controller, a corresponding message appears in the display.

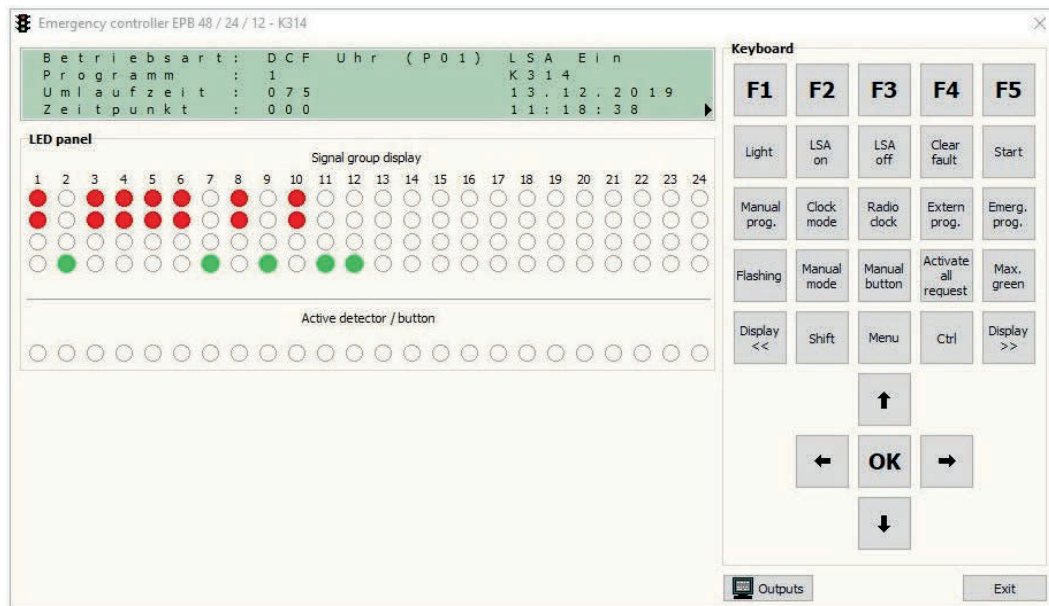

Emergency operation is then possible in the mask if a defect in the controller means it is no longer operating.

Click on **Outputs** to open the mask **Show outputs.** [☞ 4.2.9](#)

Note:

This function is only possible for EPB 12 / EPB 24 / EPB 48 from version 6.50

5.2 Send data to controller

Opens the function for sending data to the controller. [☞ 4.2.5](#)

5.3 Import data from controller

Opens the function for importing data from the controller. [☞ 4.2.6](#)

5.4 Change parameters online

Changes some program parameters while the controller is operating.

This function is only supported by controller types EPB 12 / EPB 24 / EPB 48.

A confirmation query for the user code appears. This is automatically preset, depending on the default in the program settings.

The function is not possible if the wrong user code is entered or if there is no connection to the controller, triggering a corresponding error message.

When the right user code is entered, the corresponding mask opens. The header shows the interface being used and the current program name from the controller.

Note:

If parameters have been changed at the controller, when the mask is closed a query appears whether the current program should be imported from the control.

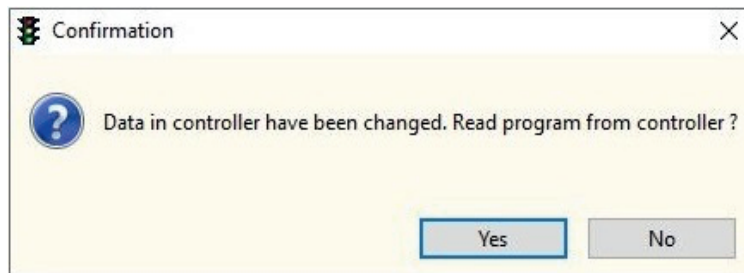

Depending on the confirmation, the corresponding function appears for importing the program from the controller.

5.4.1 Green phase parameters

The parameters for vehicle actuation are changed in this entry mask. Adjustments can be made to the extension times and time gaps.

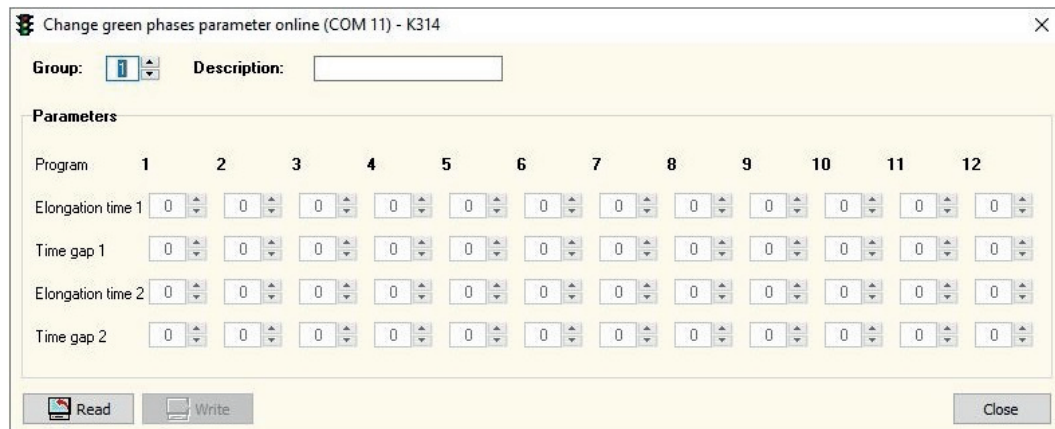

Select the required group in the **Group** input box. Click on **Read** to import the current parameters and the group name for the selected group from the controller, filling the corresponding input boxes.

Extension time 1+2 and time gap 1+2 can be changed for each group.

As soon as the data from the controller have been imported, **Write** is enabled.

Note:

Entering **0** for the extension time means there is no more extension in this extension point.

Entering **0** for a time gap means that the affected extension point is lengthened to the maximum extension point.

Clicking on **Write** triggers the following query:



Confirm with **Yes** to transfer the data to the controller. No other message appears.

Note:

Selecting another group deletes the visible data. Press **Read** again to import and display the data of the selected group
Data input is always for 12 programs. But depending on the controller software version, only data for programs 1 to 6 are transferred.

5.4.2 Progressive signalling

The parameters for progressive signalling are changed in this entry mask.
The parameters sync., duration, sync. delay and sync. output can be adjusted for two separate entries.

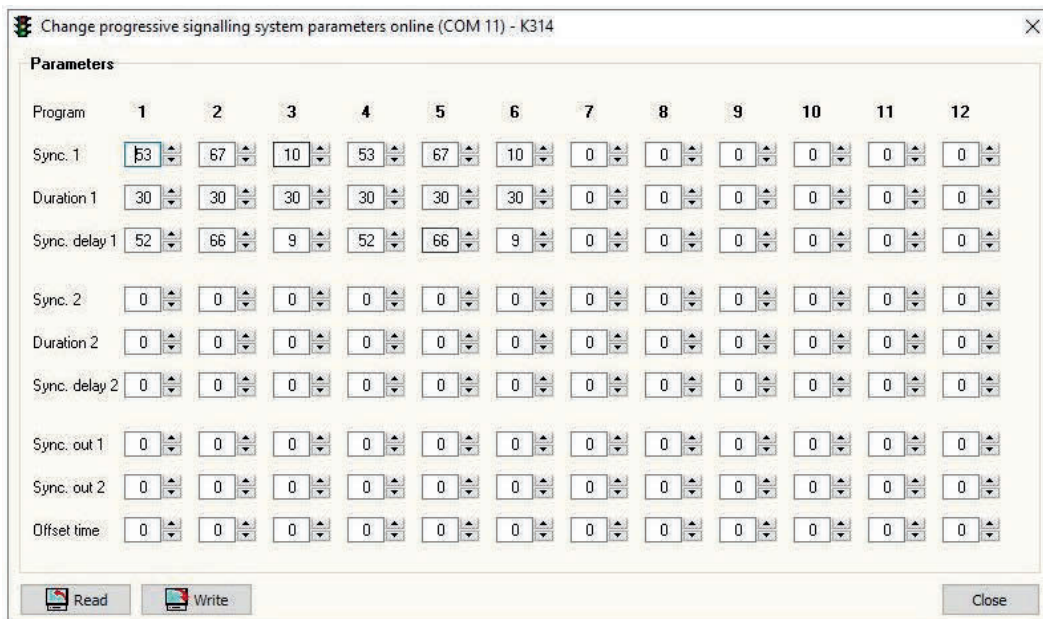

Click on **Read** to import the current parameters from the controller, filling the input boxes with the imported values.

The necessary parameters can be changed according to the program.
As soon as the data from the controller have been imported, **Write** is enabled.

Clicking on **Write** triggers the following query:

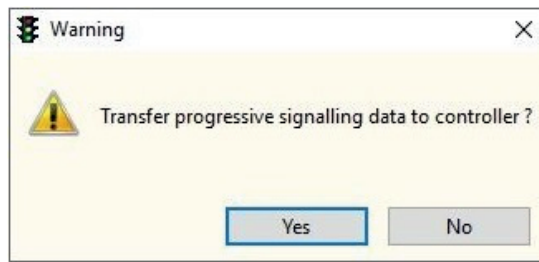

Confirm with **Yes** to transfer the data to the controller. No other message appears.

5.4.3 Switching times

Changes the switching points of the internal clock in ongoing operation.
This function is currently not available

5.5 Show outputs

Calls up the Show outputs function.  4.2.8

5.6 Switching the monitoring functions

Calls up the Switching monitoring function.  4.2.9

5.7 Set date and time

The date and time settings in the controller are always up to date so that program changeovers via the internal clock are carried out at the right moment time and the right time is stated in error reports.

Every time the controller is programmed, the date and time are automatically transferred from the connected PC and adjusted accordingly.

5.7.1 Set date and time manually

Every time that the mask is opened, the current PC values are preset in the selection boxes.

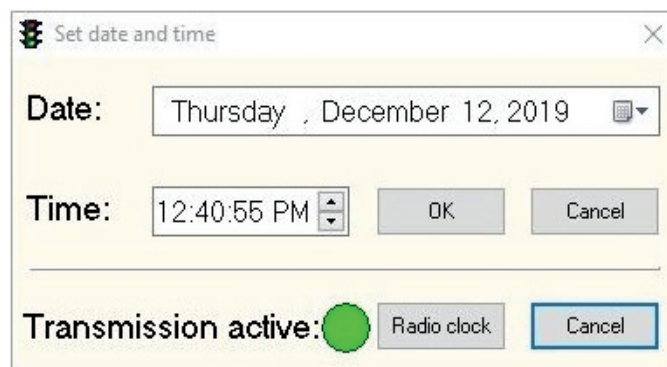

The marked values can be changed in the **Date** box with the **up / down** arrow buttons. The **left / right** arrow buttons change the selection in the box.

Click the left mouse button on the down arrow to open the calendar for free selection of the date. In the **Time** box, the time is changed with the up/down arrows.

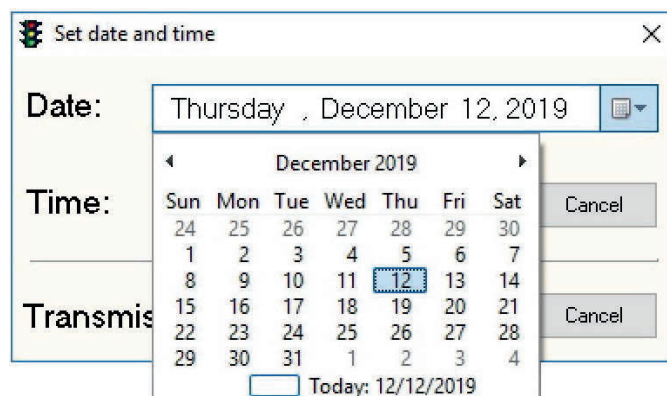

Click on **OK** to transfer the currently displayed date and time to the controller.

To check, the **Transmission active** display flashes briefly and the window closes automatically. A corresponding error window appears if there is no connection to the controller.

5.7.2 PC time

Click on **PC time** to transfer the current time and date from the PC to the controller. To check, a control lamp flashes briefly behind the words **Transmission active**. The window closes automatically after transmission is completed.

Note:

If a radio clock type V4 is plugged in (supported for EPB 12 / EPB 24 / EPB 48 from version 6.60), **Radio clock** appears instead of **PC time**. ➔ 5.7.3

5.7.3 Radio clock

Click on **Radio clock** to transfer the current time and date from the radio clock type V4 to the controller. To check, a control lamp flashes briefly behind the words **Transmission active**. The window closes automatically after transmission is completed.

Note:

This function is only supported for EPB 12 / EPB 24 / EPB 48 from version 6.60 in combination with a radio clock type V4.

5.8 Test outputs

With controller types EPB 12 / EPB 24 / EPB 48, all signal outputs can be triggered individually for testing.

It is thus possible to check whether the outside system has been connected correctly. The corresponding port appears in the window header. The system status is polled by the controller when this function is selected. A corresponding error message appears if there is no connection to the controller. To test the individual outputs, the controller first has to be turned off with **TLS Off**. The following message appears if this condition is not fulfilled:

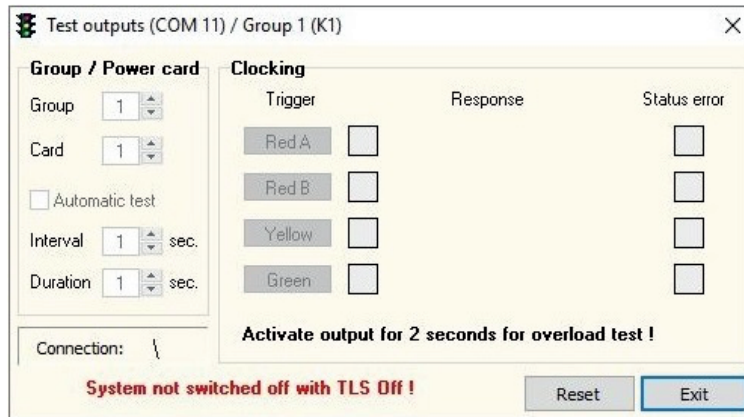

If the controller was turned off with **TLS Off**, the system checks whether the key switch on the controller is set to **Clocking**. Otherwise a corresponding message appears.

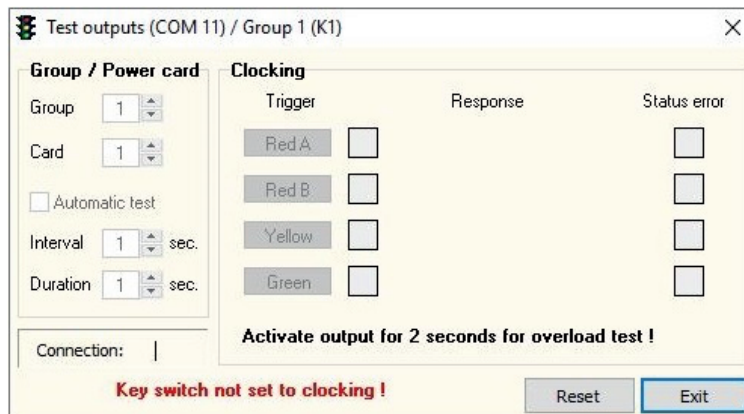

If both conditions are fulfilled, all control elements are enabled.

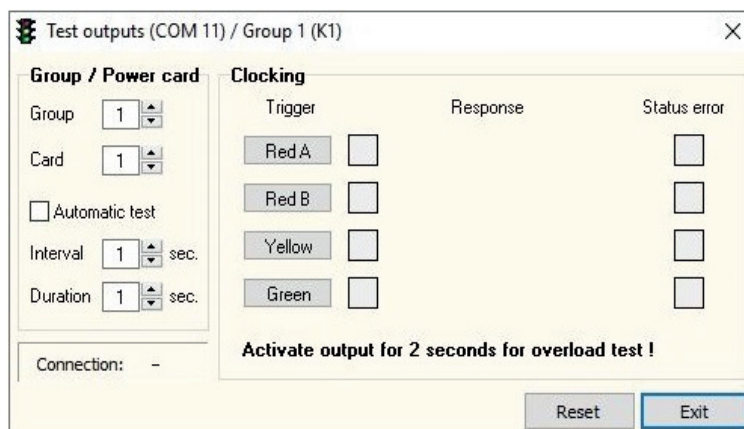

A corresponding error message appears if the connection to the controller is interrupted.

5.8.1 Trigger outputs

Adjust the required group / power card in the **Group** and **Power card** selection boxes. If the selected power card is not available, all control elements are disabled. A corresponding message appears.

Note:

It is not possible to select a power card for controller type EPB 12 as there is only one power card for every group.

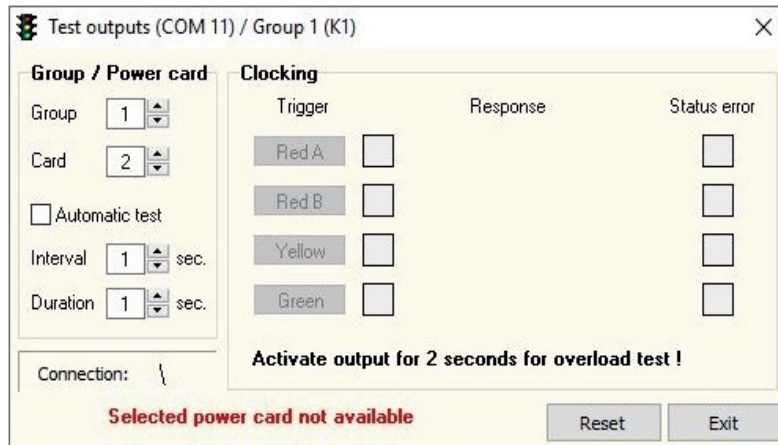

On selecting a valid power card, all control elements will be enabled again.

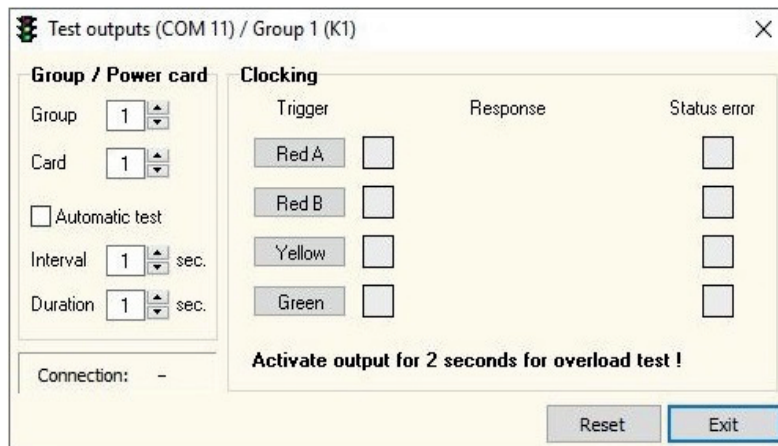

Trigger the required lamp output with **Trigger**.

Click and hold with the left mouse button to activate the button until released again.

The corresponding control lamp lights up to the right of the trigger.

Clicking with the right mouse button locks a button and makes the output permanent. Click with the left mouse button to switch off.

When the PC / control connection is active, a rotating bar is activated as a check. Click on **Reset** to switch all triggered lamps off and reset the group / power card selection back to the default.

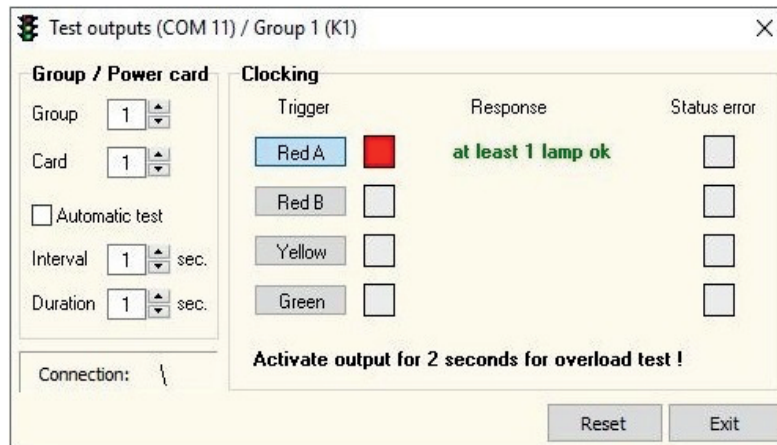

If a group is clocked, the corresponding status lamp lights up. The lamps of the connected signal heads are also checked.

If at least one lamp lights up at the triggered output, at least one lamp lights up OK as feedback for the corresponding output.

If no lamp lights up at the triggered output or if no signal heads are connected to this output, **No response** appears as feedback for the corresponding output.

Note:

No response also appears when the corresponding group is set to lamp measurement and an LED signal head is connected.

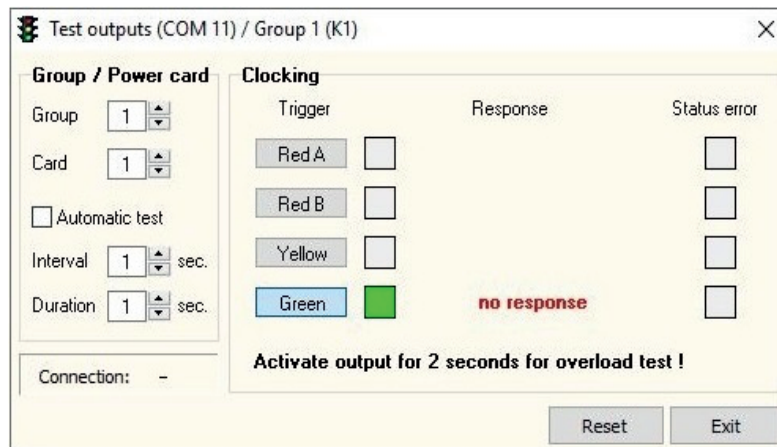

In addition, every output is also checked for status errors. If a status error is found, an optical warning appears after the corresponding output. In this case, triggering is not switched off for troubleshooting.

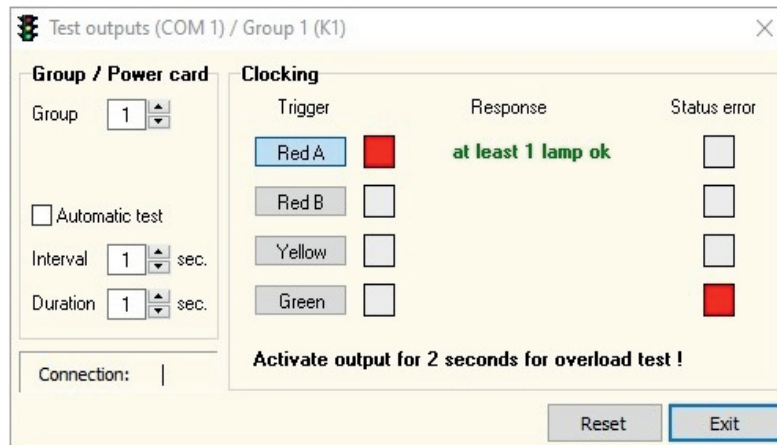

The following error message could have the following causes:
Wiring error in the outside system, output fuse defective or defective power card(s).
The current triggering is then switched off immediately.

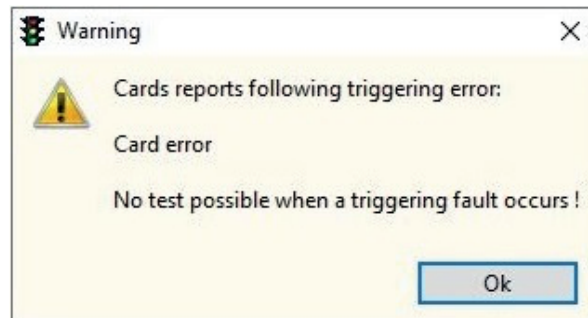

Note:

If **at least 1 lamp OK** appears, it is possible that some lamps could be defective. But this is only the case when several signal heads are connected to a power card, as they are connected in parallel according to the output.

Triggered outputs are switched off immediately in the following cases:

- Selection of another group or power card
- Interrupted connection PC / controller
- Closing the window
- As soon as the window is closed
- Overload or short-circuit

Each output is checked for overload/short-circuit during clocking.

If overload is detected at a lamp output, triggering of the affected output is disabled and the following message appears:

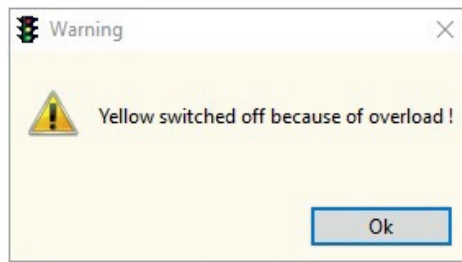

A corresponding message appears after the affected output.

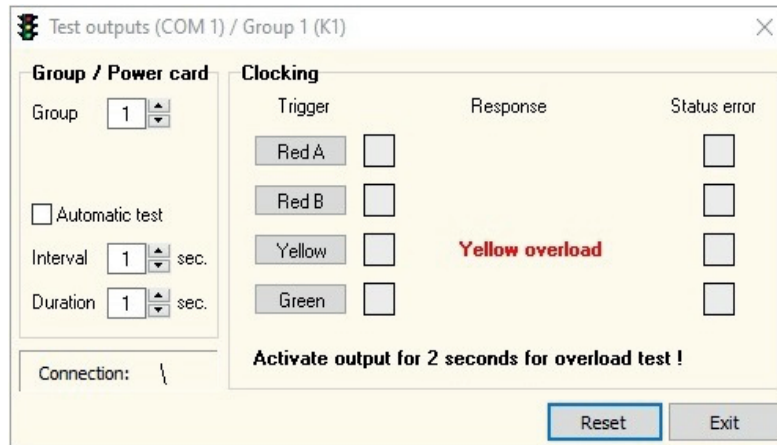

5.8.2 Automatic lamp output test

On selecting this function, firstly the active groups (and the number of power cards for EPB 24 / EPB 48) are ascertained for the program currently running in the controller.

A power card list is created. This takes approx. 10 to 15 seconds, depending on controller type. On completion, all outputs are automatically triggered in the active groups (and power cards for EPB 24 / 48).

The value shown in **Interval** shows the interval during which triggering changes between the individual outputs. The value shown in **Duration** shows how long an output is triggered. The times can be adjusted between 1 to 5 seconds in each case.

Group / Power card		Clocking		
Group	12	Trigger	Response	Status error
Card	4	Red A	<input type="checkbox"/>	<input type="checkbox"/>
<input checked="" type="checkbox"/> Automatic test		Red B	<input type="checkbox"/>	<input type="checkbox"/>
Interval	1 sec.	Yellow	<input type="checkbox"/>	<input type="checkbox"/>
Duration	1 sec.	Green	<input type="checkbox"/>	<input type="checkbox"/>

Activate output for 2 seconds for overload test !

All other control elements are disabled when this function is active. The **Group** box (power card only for EPB 24 / EPB 48) shows which group is being triggered. The corresponding trigger lamp lights up to check the output.

All feedback functions work in the same way as for manual triggering.

If auto-test is turned off or if **Reset** is selected, all operating and display elements are reset to default. Triggered outputs are turned off again.

Note:

If all outputs have been triggered once, the test cycle begins again with the first group.

The repetition continues until the function is turned off.

From CPU version 6.90, all test results are also sent to the operating logbook.

5.9 Power card information

This function reveals the software version of the power cards for controller types EPB 12 / EPB 24 / EPB 48.

The screenshot shows a window titled "Power card information (COM 11)" with a close button in the top right corner. The window is divided into two main sections: "Data bus 1" and "Data bus 2". Each section contains a table with 8 columns: No., H.addr, V.addr, Type, LED, Ctrl, Sisi, and Res. The "Data bus 1" table has 24 rows, with the first 12 rows populated with data. The "Data bus 2" table also has 24 rows, with the first 8 rows populated with data. At the bottom right of the window, there are two buttons: "Refresh" and "Close".

Data bus 1								Data bus 2							
No.:	H.addr	V.addr.	Type	LED	Ctrl	Sisi	Res.	No.:	H.addr	V.addr.	Type	LED	Ctrl	Sisi	Res.
1	01/1	01/1	PWK 24	X	V1.05	V1.05		1	13/1	13/1	PWK 24	X	V1.05	V1.05	
2	03/1	03/1	PWK 24	X	V1.05	V1.05		2	14/1	14/1	PWK 24	X	V1.05	V1.05	
3	04/1	04/1	PWK 24	X	V1.05	V1.05		3	15/1	15/1	PWK 24	X	V1.05	V1.05	
4	05/1	05/1	PWK 24	X	V1.05	V1.05		4	16/1	16/1	PWK 24	X	V1.05	V1.05	
5	06/1	06/1	PWK 24	X	V1.05	V1.05		5	17/1	17/1	PWK 24	X	V1.05	V1.05	
6	07/1	07/1	PWK 24	X	V1.05	V1.05		6	18/1	18/1	PWK 24	X	V1.05	V1.05	
7	08/1	08/1	PWK 24	X	V1.05	V1.05		7	19/1	19/1	PWK 24	X	V1.05	V1.05	
8	09/1	09/1	PWK 24	X	V1.05	V1.05		8	20/1	20/1	PWK 24	X	V1.05	V1.05	
9	10/1	10/1	PWK 24	X	V1.05	V1.05		9							
10	11/1	11/1	PWK 24	X	V1.05	V1.05		10							
11	12/1	12/1	PWK 24	X	V1.05	V1.05		11							
12								12							
13								13							
14								14							
15								15							
16								16							
17								17							
18								18							
19								19							
20								20							
21								21							
22								22							
23								23							
24								24							

The display shows a hardware address (power card address), a virtual address (group address), the power card type (PWK 24, PWK 48, or PWK 12), LED measurement active and the software version.

Notes:

- This function is only supported from version 6.10 of the software.
- For power cards with older software versions that do not send this information, question marks appear for LED info and software version.
- Displaying the hardware and virtual address is intended for internal test purposes.

5.10 User access

This function changes the previous user code in a controller. This is necessary when controllers are rented or similar by other users. To give the respective user access to the controller with his own user code, this has to be enabled first.

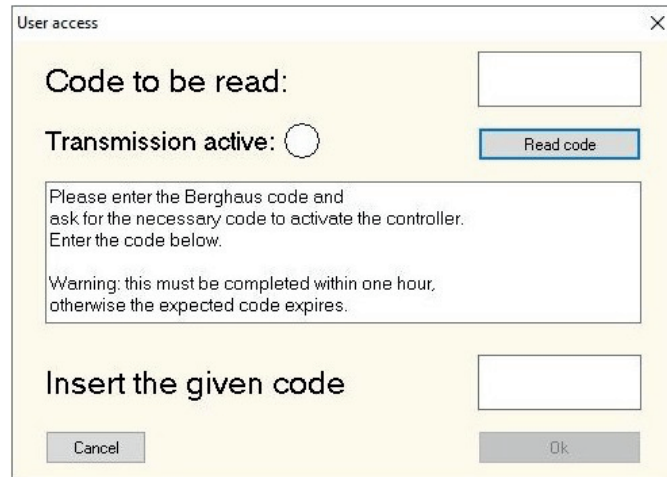

The screenshot shows a dialog box titled "User access" with a close button (X) in the top right corner. The dialog has a light yellow background. It contains the following elements from top to bottom:

- A text input field labeled "Code to be read:".
- A "Transmission active:" label followed by an unchecked radio button and a blue "Read code" button.
- A text area containing the text: "Please enter the Berghaus code and ask for the necessary code to activate the controller. Enter the code below." and a warning: "Warning: this must be completed within one hour, otherwise the expected code expires."
- A text input field labeled "Insert the given code".
- At the bottom, there are two buttons: "Cancel" on the left and "Ok" on the right.

Press "**Read code**" to read a code from the controller. Notify Peter Berghaus GmbH of this number combination within one hour. You will then receive your code to enter in the field **Enter the given code**. Press **OK** to confirm.

If a wrong code is entered, you will see the message **Wrong code** and the procedure is cancelled.

When the code is entered correctly, the controller is enabled and the window closes automatically.

The value of 99 appears as confirmation in the **Show outputs** window behind the **User** window.

The next valid user code received by the controller is then activated in the controller.

The controller then only accepts this code until it is enabled again.

Note:

A corresponding error message appears if there is no connection to the controller and the procedure is cancelled.

6. Create program

6.1 Basic data

This menu point features all functions for diverse masks used to enter various basic parameters.

6.1.1 Program description

Select Program description to open an input window for entering text. Accompanying tests to the current program can be entered here. On saving the current program, this text is saved under the chosen file name with the suffix .txt. The text can be viewed or printed with any editor.

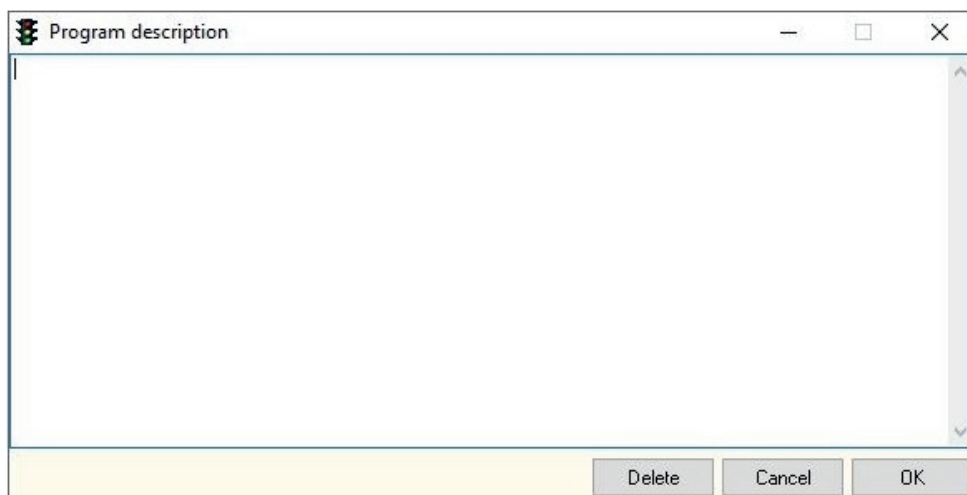

The screenshot shows a window titled "Program description". The window contains a large, empty text area for entering text. At the bottom right of the window, there are three buttons: "Delete", "Cancel", and "OK".

6.1.2 General data

This function opens a window for entering further information about the program. These details then appear on every subsequent printout.

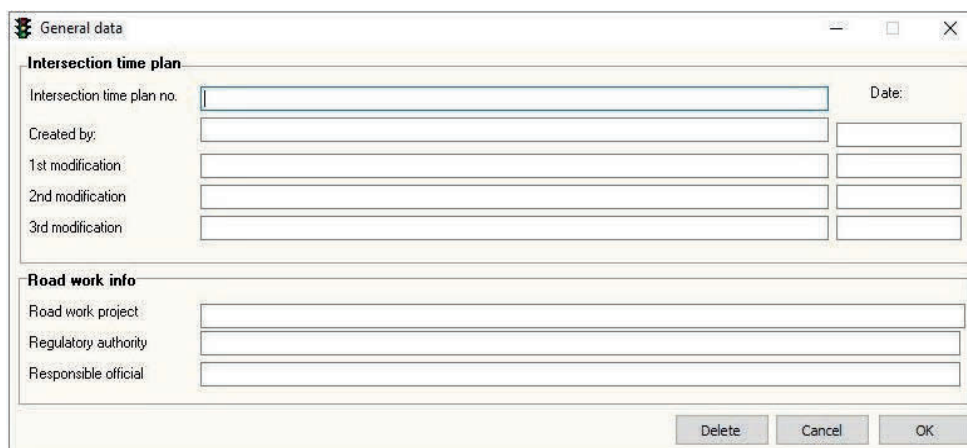

The screenshot shows a window titled "General data". It is divided into two main sections:

- Intersection time plan:** This section includes a "Date:" label, an "Intersection time plan no." input field, a "Created by:" input field, and three "1st modification", "2nd modification", and "3rd modification" input fields, each with a corresponding date input field.
- Road work info:** This section includes three input fields for "Road work project", "Regulatory authority", and "Responsible official".

At the bottom right of the window, there are three buttons: "Delete", "Cancel", and "OK".

Note:

Press **F5** when in a date box for the current date to be inserted automatically.

6.1.3 Signal groups master data

All basic data for every active group are managed in this entry mask.
When interim times are calculated, the corresponding defaults are then preset in the calculation mask for every group.
Every parameter in the calculation mask can also be changed separately (depending on the calculation process).

Note:

Every time the mask is closed, a test program starts automatically and reports any errors or changes in an existing intersection time plan.

Designation	Signal groups type	Red-yellow	Yellow	Min green	Clearance speed	Passage time	Entry speed	Vehicle length (m)	Flashing	Request	Blank / catch	Transition time Blank / catch
Signal group 1	Car, truck, bus	1	4	10	30 km/h (8,333 m/s)	4	40 km/h (11,111 m/s)	0	<input type="checkbox"/>	<input type="checkbox"/>	<input type="checkbox"/>	Red-yellow 0 / Yellow 0
Signal group 2	Car, truck, bus	1	4	10	30 km/h (8,333 m/s)	4	40 km/h (11,111 m/s)	0	<input type="checkbox"/>	<input type="checkbox"/>	<input type="checkbox"/>	Red-yellow 0 / Yellow 0
Signal group 3	Car, truck, bus	1	4	10	30 km/h (8,333 m/s)	4	40 km/h (11,111 m/s)	0	<input type="checkbox"/>	<input type="checkbox"/>	<input type="checkbox"/>	Red-yellow 0 / Yellow 0
Signal group 4	Car, truck, bus	1	4	10	30 km/h (8,333 m/s)	4	40 km/h (11,111 m/s)	0	<input type="checkbox"/>	<input type="checkbox"/>	<input type="checkbox"/>	Red-yellow 0 / Yellow 0
Signal group 5	Car, truck, bus	1	4	10	30 km/h (8,333 m/s)	4	40 km/h (11,111 m/s)	0	<input type="checkbox"/>	<input type="checkbox"/>	<input type="checkbox"/>	Red-yellow 0 / Yellow 0
Signal group 6	Car, truck, bus	1	4	10	30 km/h (8,333 m/s)	4	40 km/h (11,111 m/s)	0	<input type="checkbox"/>	<input type="checkbox"/>	<input type="checkbox"/>	Red-yellow 0 / Yellow 0
Signal group 7	Car, truck, bus	1	4	10	30 km/h (8,333 m/s)	4	40 km/h (11,111 m/s)	0	<input type="checkbox"/>	<input type="checkbox"/>	<input type="checkbox"/>	Red-yellow 0 / Yellow 0
Signal group 8	Car, truck, bus	1	4	10	30 km/h (8,333 m/s)	4	40 km/h (11,111 m/s)	0	<input type="checkbox"/>	<input type="checkbox"/>	<input type="checkbox"/>	Red-yellow 0 / Yellow 0

6.1.3.1 Signal group name

The name of the respective groups is entered here according to the map.
This name appears later on the printouts or in displays of error messages etc., depending on the controller.

Press **Enter** to go from group name to group name within the active tab.

Note:

A name must be entered for every active group, otherwise it is not possible to close this mask. A corresponding message appears.

6.1.3.2 Signal group type

A signal group type is allocated to each group in this box. Some of the parameters in this group change depending on the selected type. Corresponding defaults are then preset, but these can be changed at any time.

Note:

The signal group type can only be changed for groups where nothing has been drawn yet in the intersection time plan.

If an attempt is made to change the type for a group already processed in the intersection time plan, the following message appears:

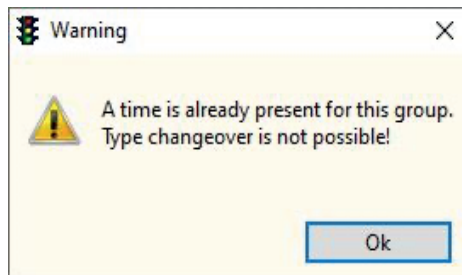

After pressing OK to confirm, the type for this group is reset to the original value.

Note:

There are also a number of acknowledgement signals (ACK-xxxx) which are assigned a fixed function (output of a confirmation signal), depending on the CPU software version.

- ACK PC Req: program change on request function is active
- ACK Ext Canc.: cancel extension time function is active
- ACK Ext Canc.SP: extension time function, controller standstill in stopping point
- ACK Cont Red: continuous red function is active
- ACK Cont Red SP: continuous red function, controller standstill in stopping point
- ACK Cont Red WP: continuous red function, continuous red status achieved
- ACK Man SW: manual mode function, controller standstill in waiting point
- ACK Man RW: manual mode function, controller running in waiting point
- ACK LPT: local public transport function is active
- ACK LPT SP: local public transport function, controller standstill in stopping point
- ACK Blanking: blanking function is active

There are also auxiliary signals, tactile signal heads and alternate blinkers but no fixed function is allocated. In this case, defaults appear in the signal head equipment, signal safeguarding etc.

6.1.3.3 Red-yellow / yellow phases

Defines the red-yellow and yellow phases in every single group in the intersection time plan.

6.1.3.4 Min release

Stipulates the minimum release time for each group. It is not possible to enter release times in the intersection time plan editor that are smaller than this adjusted value.
The controller uses these values to monitor the minimum release times.
If they are violated in the program, the controller switches off due to a minimum release time error.

Note:

The minimum release times restriction (less than 5 seconds) can be disabled with password confirmation when it is necessary e.g. to plan flow control with very short release times.

6.1.3.5 Clearance speed

Defaults for clearance speed are entered depending on the adjusted signal group type.
These values can also be changed with a free entry (numbers only). On leaving the box, a query appears whether the clearance speed should be calculated in **km/h** or **m/s**. The interim times are then calculated with these values.

Note:

If manual interim time input was activated in the main mask, these input boxes are empty and blocked.

6.1.3.6 Crossing time

Defaults for crossing time are entered depending on the adjusted signal group type. These are then included in calculating the interim times.

Note:

If manual interim time input was activated in the main mask, these input boxes are empty and blocked.

6.1.3.7 Entry speed

Defaults for entry speeds are entered depending on the adjusted signal group type.
When calculating the interim times with entry times, these defaults are used to ascertain the entry times.
These values can also be changed with a free input (numbers only). On leaving the box, a query appears whether the clearance speed should be calculated in **km/h** or **m/s**.
This value then defines the basic values in the window for calculating the interim times.

Note:

If manual interim time input was activated in the main mask, these input boxes are empty and blocked.

6.1.3.8 Vehicle length

If the function for calculating vehicle lengths is activated in the main mask, the entered value is added to the clearance distances in the calculation mask.
Standard RiLSA values are used as defaults, depending on the adjusted signal group type.

Note:

If manual interim time input was activated in the main mask, these input boxes are empty and blocked.

6.1.3.9 Flashing

This box defines whether the respective groups switch to yellow flashing when there is a fault or when the flashing mode is selected.

6.1.3.10 Activate request mode

The **Request** box defines whether the request mode is activated for the respective group in the intersection time plan editor. The corresponding functions for each group are then enabled.

Note:

Every time the mask is closed, the system checks whether request mode has been activated for one of the active groups. If this is the case, a confirmation query appears for the forced cycle. ☞

6.1.6

6.1.3.11 Blanking / capture signal

Select this checkbox to preset the following parameters for the corresponding signal groups:

1. In the signal head equipment, the signal head is preset as 2-aspect with red and yellow.
2. In signal safeguarding, there is no status monitoring for green with this group.

6.1.3.12 Transition times for blanking / capture signal

In the selection box "**Transition times for blanking / capture signal**", you can select the required colour sequence to be used for drawing a blank phase in the intersection time plan editor.

Notes:

- When a colour sequence is adjusted that does not comply with RiLSA, a corresponding message appears.
- The output of blanking is supported by EPB 12 / EPB 24 / EPB 48 from version 7.20.

6.1.3.13 Changing the calculation parameters

If changes have been made to one of the calculation parameters such as clearance speed, crossing time, entry speed or vehicle length, the system checks whether interim times have already been calculated when the mask is closed. If so, the following message appears:

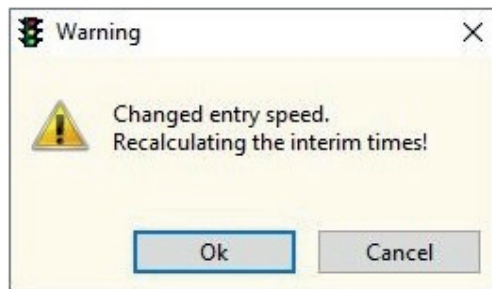

After confirming with **OK**, the interim times are recalculated with the changed parameters. Clicking on Cancel does not close the actual mask.

If the query is confirmed with **OK**, the system checks whether there are any manually changed parameters in the mask for calculating the interim times. If so, the following query appears:

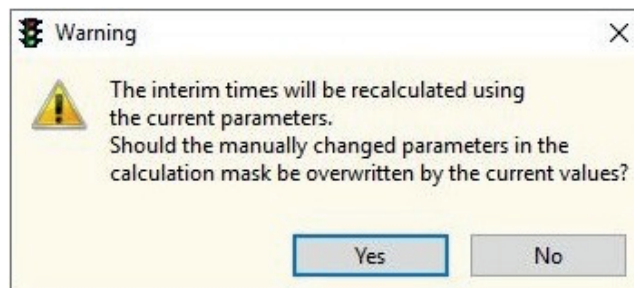

If the query is confirmed with **Yes**, all manually changed parameters in the calculation mask are replaced with the current values in the signal group master data and the interim times are recalculated with these values.

If the query is confirmed with **No**, manually changed parameters remain in the calculation mask and the interim times are recalculated with the changed parameters.

6.1.3.14 Automatic signal safeguarding adjustment

If the master data are closed after a signal group type has been changed, the following query appears:

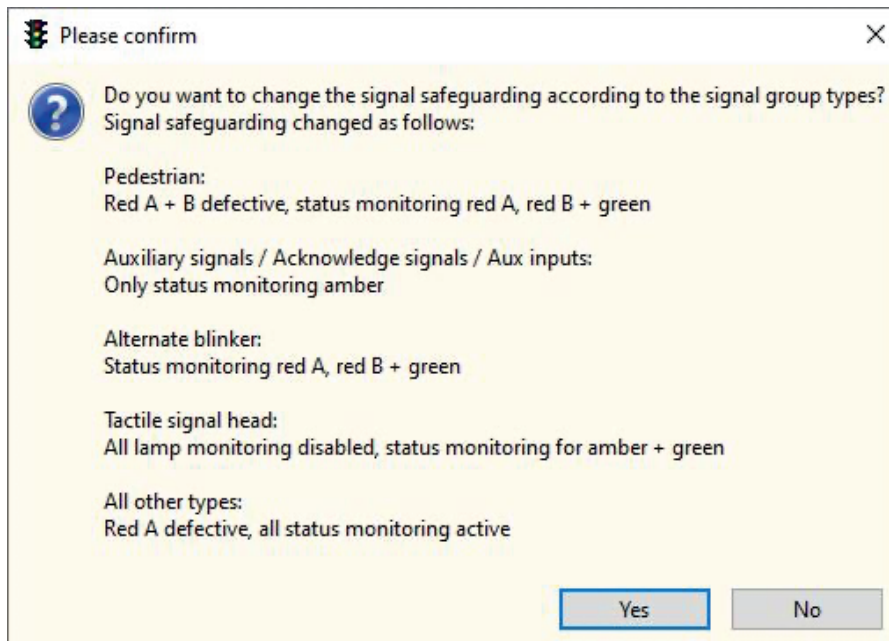

Depending on how this is confirmed, the corresponding settings in the signal safeguarding are entered for all groups. Any entries that have already been made are changed. Signal safeguarding must be checked for completeness!

Note:

This function is only available from Ampeltools version 1.20 and is only carried out for controller types EPB 12 / EPB 24 / EPB 48.

6.1.4 Signal head equipment

This mask allocates the equipment for every signal head in a signal group (mask such as e.g. arrow templates, together with colour, diameter and lamp). The entered data are just used for printouts of the signal head equipment.

Signal head equipment - Group 1 (K1)

Group

1 2 3 4 5 6 7 8 9 10 11 12 13 14 15 16 17 18 19 20 21 22 23 24 25 26 27 28 29 30 31 32

Signal head

No. of chambers 3-aspect No. of signal heads 2 for group 1 (K1)

Signal head 1

Mask Colour Diameter Lamp

red 200 LED

amber 200 LED

green 200 LED

contrast visor

Signal head 2

Mask Colour Diameter Lamp

red 200 LED

amber 200 LED

green 200 LED

contrast visor

Signal head 3

Mask Colour Diameter Lamp

contrast visor

Signal head 4

Mask Colour Diameter Lamp

contrast visor

Copy Delete Cancel Ok

When the mask is opened for the first time, two signal heads are always preset for each group. This can be decreased or increased if necessary. Maximum four signal heads each with four chambers can be configured for each signal group. The active group is shown in bold.

6.1.4.1 Select signal head type

The type of signal head for the specific signal group is selected with **No. of chambers**, with the choice of one to four signal head chambers. Symbols are already preset for pedestrians and cyclists depending on the signal group type adjusted in **Signal group master data**. If necessary, these can be changed, as can the number of signal head chambers. Select the number of signal heads for each group in **No. of signal heads**. The default is two. This can be increased to maximum four signal heads for each signal group.

Note:

There must be at least one signal head incl. name for each signal group. The selected signal head type is always the same within a signal group, but can be adjusted individually. 📖 6.1.4.7.

6.1.4.2 Select templates

Click the left mouse button on a chamber of a signal head to see a choice of default symbols. There are two tabs with signal head masks in the symbol selection box. Firstly the standard symbols appear on the **Default** tab. Change to the **User** tab to see the optional user-defined symbols.



Click the left mouse button on one of the symbols to use this symbol for the corresponding signal head chamber. The selection box always shows the active signal head and the corresponding chamber for better guidance.

6.1.4.3 Select user-defined templates

The **User** tab is only visible if corresponding graphics are available. They can be found in: \\User\Documents\Ampeltools\Own Masks
Self-made graphics must be in this folder so that Ampeltools can show them for selection. Please note the following specifications for self-made graphics:

File type: JPG
Dimensions: 100 x 100 pixels
Resolution: 300 dpi

6.1.4.4 Select colour

Click the right mouse button on the displayed colour of a signal head chamber to see a menu for selecting the colour.

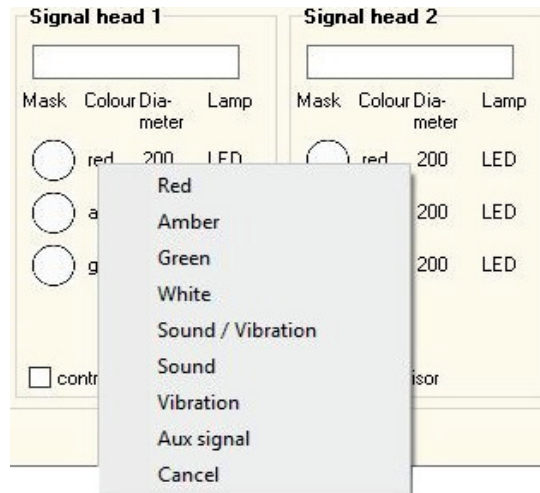

The selected colour is then saved for the respective signal chamber.

Note:

The choices Sound / Vibration, Sound only, Vibration only or Aux signal are intended for special signals. If you select one of these, it is not possible to select lamp or diameter.

6.1.4.5 Select diameter

Click the right mouse button on the displayed diameter of a signal head chamber to see a menu for selecting the diameter.

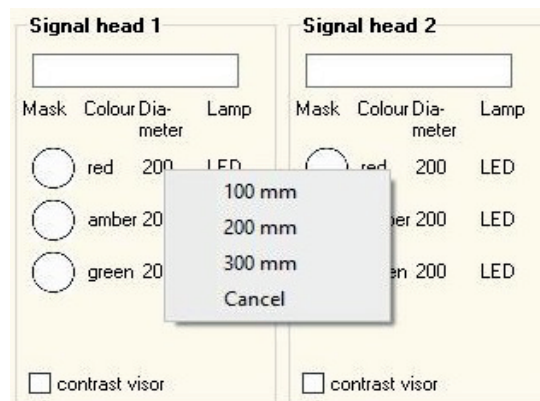

The selected diameter is then saved for the respective signal chamber.

6.1.4.6 Select lamp

Click the right mouse button on the displayed lamp of a signal head chamber to see a menu for selecting the lamp.

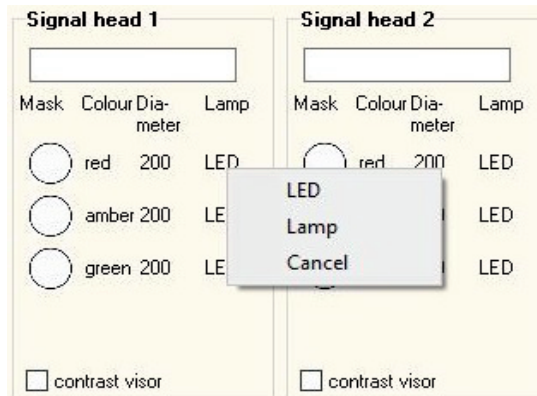

The selected lamp is then saved for the respective signal chamber.

6.1.4.7 Adapt individual signal head

This function hides or shows individual chambers for signal heads. This is necessary e.g. for two-aspect signal heads (red/green) and one-aspect signal heads (safety flashing). Click with the right mouse button on a red chamber of a signal head to see the following selection menu:

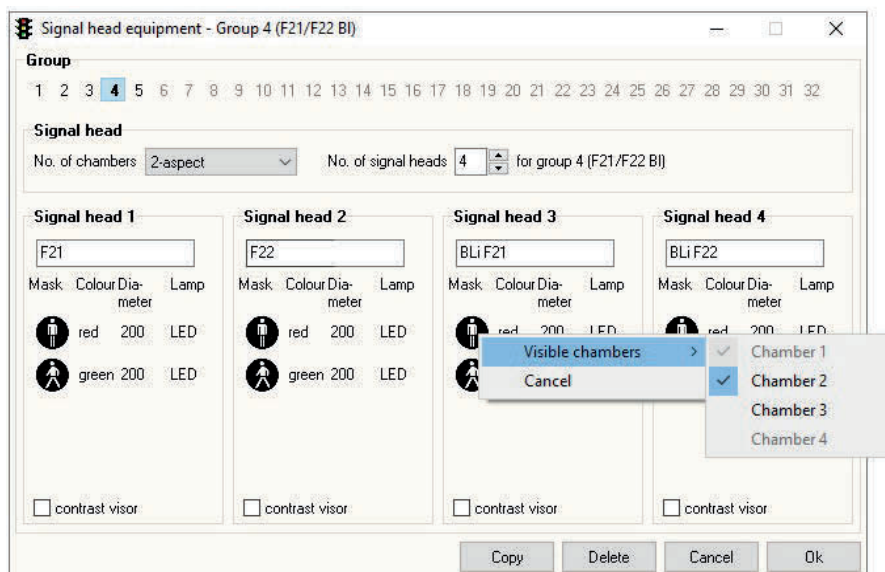

This selection menu hides or shows chambers of the selected signal head, stating the sequence. Chambers can only be hidden from bottom to top or shown from top to bottom.

Note:

This adjustment can be done separately for every signal head. The top entry in the selection menu is generally blocked as there must be at least one chamber in every signal head.

Example pedestrian group with safety flashing

Signal head equipment - Group 4 (F21/F22 B)

Group
1 2 3 4 5 6 7 8 9 10 11 12 13 14 15 16 17 18 19 20 21 22 23 24 25 26 27 28 29 30 31 32

Signal head
No. of chambers 2-aspect No. of signal heads 4 for group 4 (F21/F22 B)

Signal head 1			Signal head 2			Signal head 3			Signal head 4		
Mask	Colour	Dia- meter	Lamp	Mask	Colour	Dia- meter	Lamp	Mask	Colour	Dia- meter	Lamp
	red	200	LED		red	200	LED		amber	200	LED
	green	200	LED		green	200	LED		amber	200	LED
<input type="checkbox"/> contrast visor			<input type="checkbox"/> contrast visor			<input type="checkbox"/> contrast visor			<input type="checkbox"/> contrast visor		

Copy Delete Cancel Ok

6.1.4.7 Contrast visors

The selection box lets you choose whether the respective signal head is equipped with a contrast visor.

6.1.4.8 Copy signal head

Use this function to copy the equipment of a signal head. You can copy the data of the current signal group to other signal groups or copy the individual signal heads within one and the same signal group.

There is a choice between copying the equipment of the current signal group to other signal groups, or copying the equipment of individual signal heads within one and the same signal group.

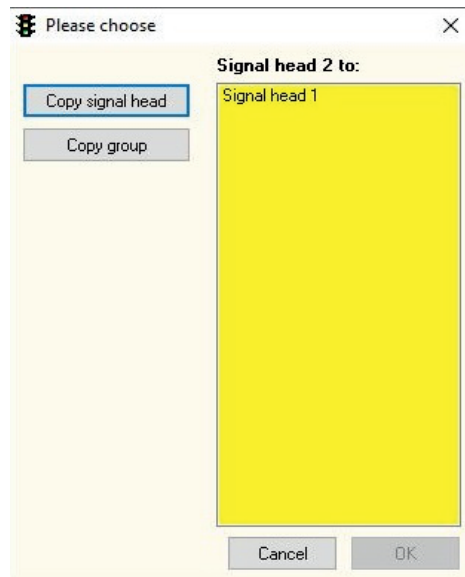

Note:

To copy a complete signal group, always use the current signal group as source. All equipment features of the heads are copied.

To copy individual signal heads within one group, the source is always the last edited signal head. If no signal head has been edited yet or if the signal group has changed, the source is always signal head 1 of the affected group.

All information is copied apart from the signal head name.

6.1.5 Green flashing

This entry mask is used to activate **Green flashing** for individual groups (only EPB 12 / EPB 24 / EPB 48).

The green lamps flash in signal groups where this function is enabled.

Group	Group	Group
<input type="checkbox"/> Group 1	<input type="checkbox"/> Group 9	<input type="checkbox"/> Group 17
<input type="checkbox"/> Group 2	<input type="checkbox"/> Group 10	<input type="checkbox"/> Group 18
<input type="checkbox"/> Group 3	<input type="checkbox"/> Group 11	<input type="checkbox"/> Group 19
<input type="checkbox"/> Group 4	<input type="checkbox"/> Group 12	<input type="checkbox"/> Group 20
<input type="checkbox"/> Group 5	<input type="checkbox"/> Group 13	<input type="checkbox"/> Group 21
<input type="checkbox"/> Group 6	<input type="checkbox"/> Group 14	<input type="checkbox"/> Group 22
<input type="checkbox"/> Group 7	<input type="checkbox"/> Group 15	<input type="checkbox"/> Group 23
<input type="checkbox"/> Group 8	<input type="checkbox"/> Group 16	<input type="checkbox"/> Group 24

Buttons: Delete, Cancel, OK

Note:

This function is only available for EPB 12 / EPB 24 / EPB 48 from version 6.50.

From version 7.00, variable output of green flashing is also possible. [👉 6.3.4.1.4](#)

The corresponding selection box is disabled for signal groups where a yellow flashing time has already been drawn in the intersection time plan or in the specific switch-off program.

6.1.6 Max. green phases

The maximum green phases for each group are entered in this mask. The entries are adjusted to the selected controller type / version. Boxes that are not needed are disabled and shown cross-hatched.

Prg./Grp.	1	2	3	4	5	6	7	8	9	10	11	12	13	14	15	16	17	18	19	20	21	22	23	24	25	26	27	28	29	30	31	32
P1	0	0	0	0	0	0	0	0	0	0	0	0	0	0	0	0	0	0	0	0	0	0	0	0	0	0	0	0	0	0	0	0
P2	0	0	0	0	0	0	0	0	0	0	0	0	0	0	0	0	0	0	0	0	0	0	0	0	0	0	0	0	0	0	0	0
P3	0	0	0	0	0	0	0	0	0	0	0	0	0	0	0	0	0	0	0	0	0	0	0	0	0	0	0	0	0	0	0	0
P4	0	0	0	0	0	0	0	0	0	0	0	0	0	0	0	0	0	0	0	0	0	0	0	0	0	0	0	0	0	0	0	0
P5	0	0	0	0	0	0	0	0	0	0	0	0	0	0	0	0	0	0	0	0	0	0	0	0	0	0	0	0	0	0	0	0
P6	0	0	0	0	0	0	0	0	0	0	0	0	0	0	0	0	0	0	0	0	0	0	0	0	0	0	0	0	0	0	0	0
P7	0	0	0	0	0	0	0	0	0	0	0	0	0	0	0	0	0	0	0	0	0	0	0	0	0	0	0	0	0	0	0	0
P8	0	0	0	0	0	0	0	0	0	0	0	0	0	0	0	0	0	0	0	0	0	0	0	0	0	0	0	0	0	0	0	0
P9	0	0	0	0	0	0	0	0	0	0	0	0	0	0	0	0	0	0	0	0	0	0	0	0	0	0	0	0	0	0	0	0
P10	0	0	0	0	0	0	0	0	0	0	0	0	0	0	0	0	0	0	0	0	0	0	0	0	0	0	0	0	0	0	0	0
P11	0	0	0	0	0	0	0	0	0	0	0	0	0	0	0	0	0	0	0	0	0	0	0	0	0	0	0	0	0	0	0	0
P12	0	0	0	0	0	0	0	0	0	0	0	0	0	0	0	0	0	0	0	0	0	0	0	0	0	0	0	0	0	0	0	0

Note:

This function is not yet available.

6.1.7 Program release

The program releases are managed here.

6.1.7.1 Default program release

This mask manages the data for the individual day programs.

No. of programs

Program 1 Program 7
 Program 2 Program 8
 Program 3 Program 9
 Program 4 Program 10
 Program 5 Program 11
 Program 6 Program 12

Emergency program
Program 1

Manual program
Program 1

Start program
Program 1

Program name

Program 1: Program 7:
Program 2: Program 8:
Program 3: Program 9:
Program 4: Program 10:
Program 5: Program 11:
Program 6: Program 12:

Buttons: Delete, Cancel, OK

6.1.7.1.1 No. of programs

This mask enables the programs that can be selected during operation. This also results in the number of programs that can be processed in the corresponding editors. If a program is disabled where data have already been entered, a query appears whether all data of the disabled program should be deleted. Depending on the confirmation, all data for this program are deleted in all masks. If a program is selected on the controller that has not been enabled, there is no program change and the controller remains in the currently active program. For controller type EPB 12 / EPB 24 / EPB 48, only the enabled programs are shown in the program selection menu (display).

Note:

Programs 7 to 12 can only be adjusted if the program planning is adjusted accordingly.

6.1.7.1.2 Program names

These boxes are used to give every program a name. The name then appears in the header of certain input windows, e.g. switching points, intersection time plan editor, etc. Printouts of the phase plans also show the program name in the header.

6.1.7.1.3 Emergency program

The required emergency program is adjusted according to the program release. All enabled programs can be selected together with blank and flashing. The controller changes automatically to the emergency program when the following errors occur:

- A valid program code is present (e.g. from radio clock / external program choice).
- An attempt is made to start the controller with a disabled program.
- The controller is started without any switching times (clock mode) for the current day (no switching times entered).

Note:

If the program release is deselected for a program selected as emergency program, the emergency program setting is changed to the smallest released program.

6.1.7.1.4 Start program

The required start program is adjusted according to the program release (only EPB 12 / EPB 24 / EPB 48).

All enabled programs can be selected together with the current entry.

Every time the controller starts, it is with the adjusted start program regardless which program is currently active.

The system then changes to the currently valid program at the next possible GSP (common switching point).

If **Current** has been chosen as start program, the controller always starts with the program that is currently active.

Note:

If the program release is disabled for a program adjusted as start program, the start program setting is changed to the smallest release program.

6.1.7.1.5 Manual program

The required manual program is adjusted according to the program release (only EPB 12 / EPB 24 / EPB 48).

All enabled programs can be selected together with the entry.

If manual mode is switched on at the controller, it changes automatically to the preset manual program. If manual mode is switched off again, the controller automatically changes to the currently active program.

If **None** is selected as manual program, the required program has to be selected (manually) for manual mode at the controller.

Note:

If the program release is disabled for a program adjusted as manual program, the manual program setting is changed to the smallest release program.

6.1.7.2 Advanced program release

Specific program selection is possible in this mask. The selection is available for every released mask.

Note:

This function is only supported from version 6.70 (only EPB 12 / EPB 24 / EPB 48).

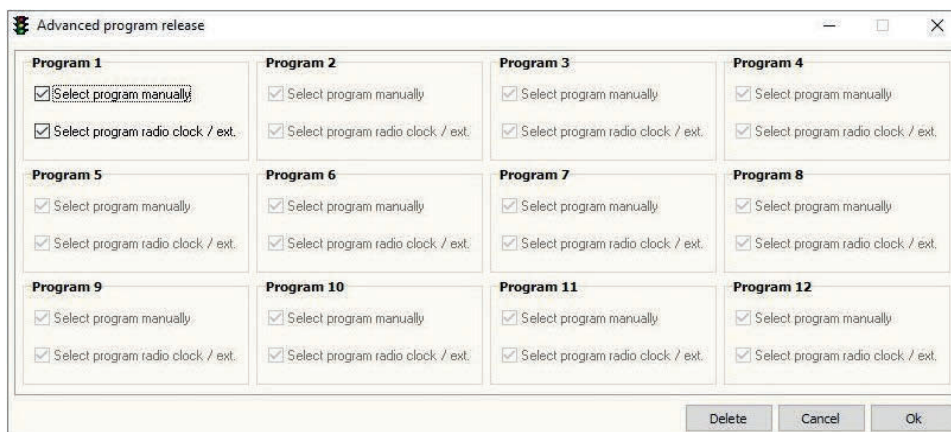

The following options are possible:

- **Select program manually**
This option shows whether the respective program can be selected on the keyboard in the **Manual** mode.
- **Select program radio clock / ext.**
This option shows whether the respective program can be selected in the **Radio clock** or **External** mode.

This function can be used to disable individual programs for the manual mode.

It is needed e.g. when a program that is only switched by program change on request cannot be selected manually on the keyboard. To this end, the **Select program manually** tick must be removed for the corresponding program.

In addition, a program can also be disabled for selection in the **Radio clock** and **External** modes. If a disabled program is selected, a corresponding message appears in the display.

Note:

At least one of the active programs must be enabled for manual mode and for selecting the **Radio clock** and **External** modes. If this is not the case, a corresponding message appears and the window cannot be closed.

6.1.8 Forced cycle

This mask manages the forced cycle for groups switching to request.
The forced cycle can be activated for every day program and a corresponding interval adjusted.

Program		Program	
1	<input checked="" type="checkbox"/> Activated every 5 minutes	7	<input checked="" type="checkbox"/> Activated every 5 minutes
2	<input checked="" type="checkbox"/> Activated every 5 minutes	8	<input checked="" type="checkbox"/> Activated every 5 minutes
3	<input checked="" type="checkbox"/> Activated every 5 minutes	9	<input checked="" type="checkbox"/> Activated every 5 minutes
4	<input checked="" type="checkbox"/> Activated every 5 minutes	10	<input checked="" type="checkbox"/> Activated every 5 minutes
5	<input checked="" type="checkbox"/> Activated every 5 minutes	11	<input checked="" type="checkbox"/> Activated every 5 minutes
6	<input checked="" type="checkbox"/> Activated every 5 minutes	12	<input checked="" type="checkbox"/> Activated every 5 minutes

Buttons: Delete, Cancel, Ok

If a group switches its green phase to request and the time after the last green phase in this group corresponds to the value entered in **every xx minutes**, an internal request is preset for this group which switches to green at the preset time.
The controller manages this function separately for every group with individual time counters.
If the forced cycle function is disabled, the entry point of all minutes is hidden.
The forced cycle interval is defined for every program.

Notes:

- This mask opens automatically if the master data entry mask is closed and request mode is activated for groups.
- This setting does not affect the program change on request function.

6.1.9 Activated groups

Individual groups can be deactivated in this mask (only EPB 12 / EPB 24 / EPB 48). They are then not enabled by the controller, regardless of whether green phases etc. have been entered or not.

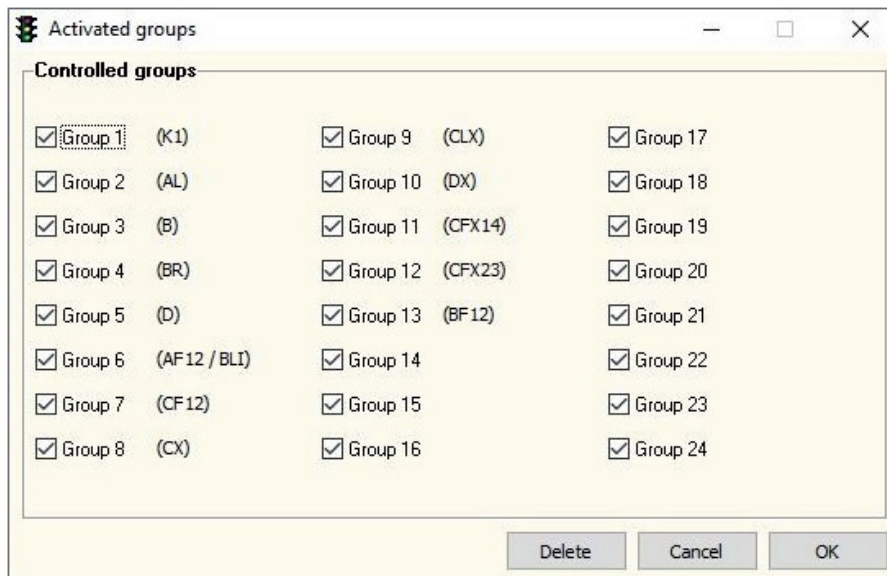

Note:

Overprogramming (only EPB 12 / EPB 24 / EPB 48) is not possible if this configuration changes in a running controller. In this case, the controller changes over to yellow flashing during data transfer!

6.1.10 Map

Select to open the map module where you can import a created map. Editing is not possible.

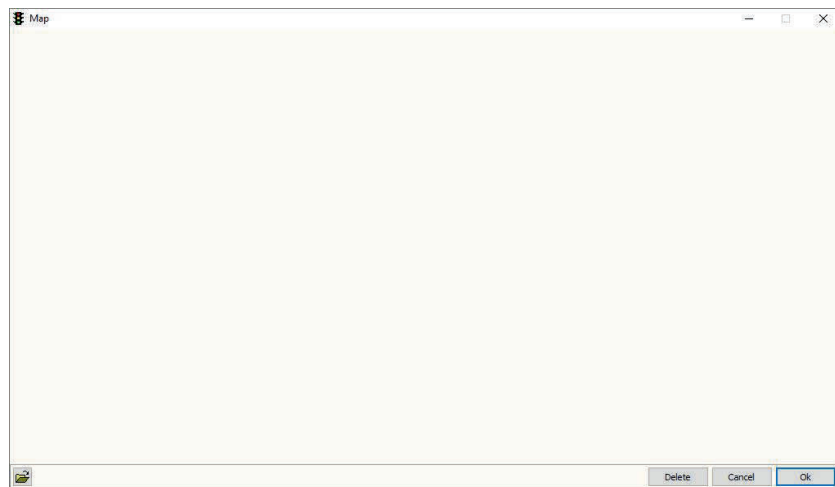

6.1.11 Import map

Use the open button (bottom left) to start graphic import. Select to open a standard Windows dialogue for selecting the required graphic.

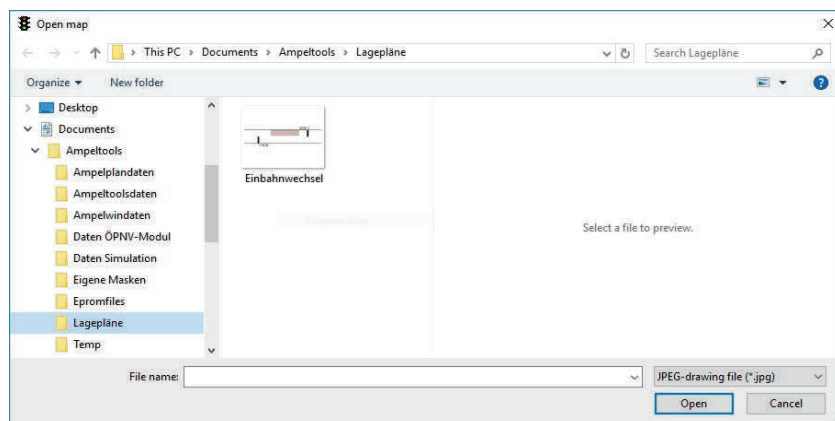

Only JPG graphic files can be imported: other formats are not supported.
The standard import directory is "C:\Users*\Username*\Dokumente\Ampeltools\Lagepläne" as fixed default.

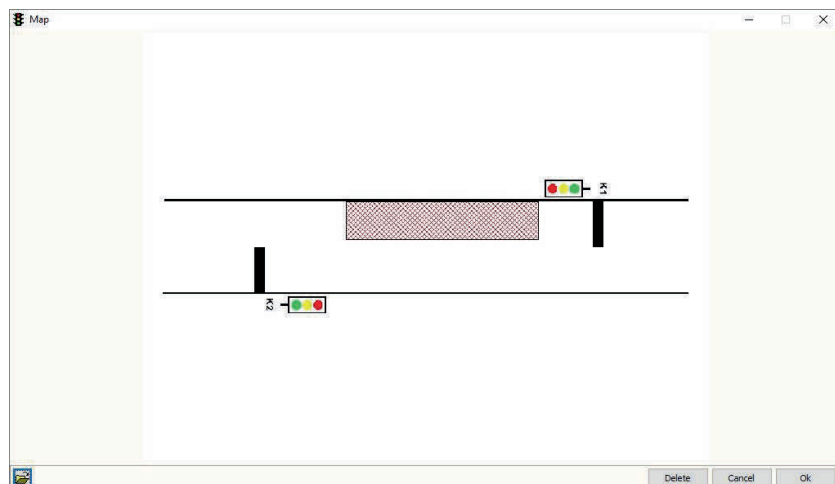

6.1.12 Delete map

If you use the delete button, an existing site plan is removed from the site plan module without further prompting.

6.1.13 Save map

There is no separate function for saving the map. On importing a map, it is automatically saved as soon as the Ampeltools data are saved. A JPG file is saved with the same name as the Ampeltools file.

Note:

If a map is deleted from the map module, the corresponding graphic file is also deleted when the Ampeltools data are saved.

6.2 Interim times

Depending on the setting in the main menu, the interim times are either calculated or entered manually.

If they are calculated, the interim times matrix is created automatically from the calculation results.

Note:

From program version 1.20, the sequence in the menu structure changes according to the setting (calculate interim times or manual entry).

The sequence needed for this current setting then appears every time.

Menu structure for calculating interim time:

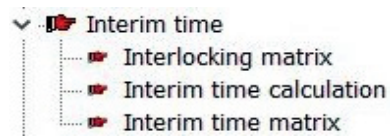

Menu structure for manual entry:

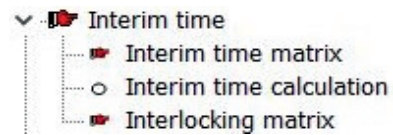

6.2.1 Interlocking matrix (green interlocking)

All hostilities between the groups (green interlocking) are selected in this mask. The entries are adjusted to the selected controller type / version. Boxes that are not needed are disabled and shown cross-hatched.

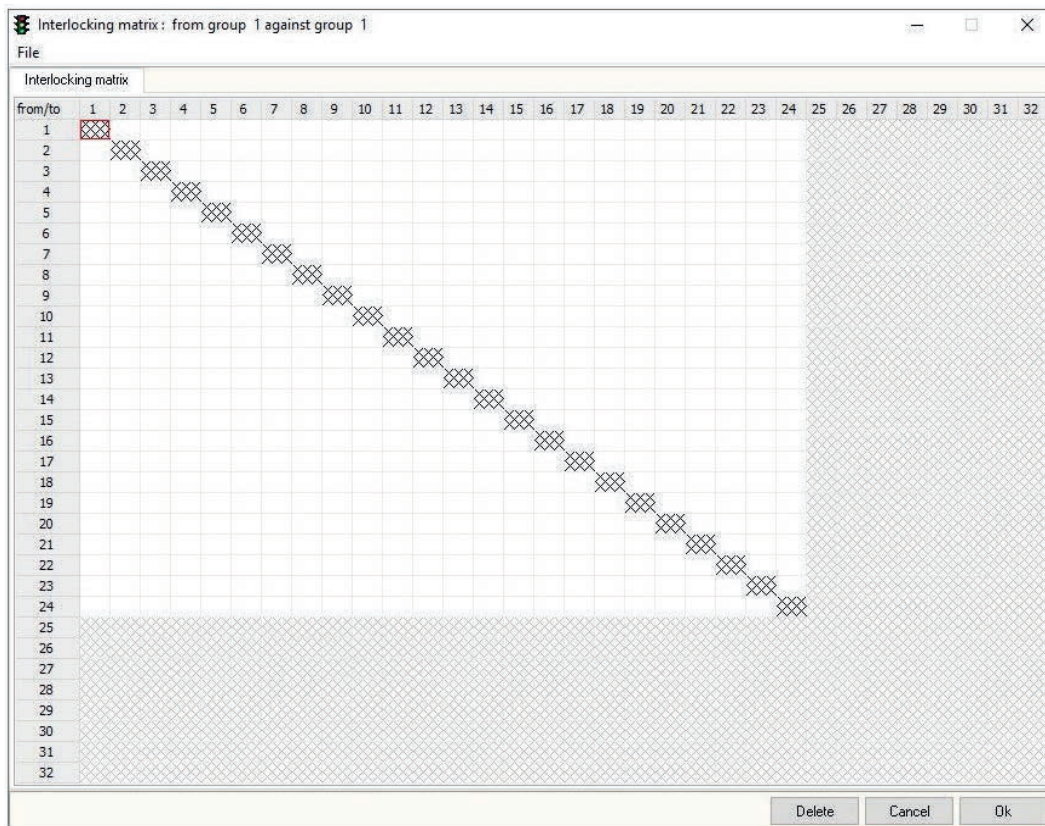

When the interim times are calculated, the matrix of the calculated interim times is created according to these entries.

If the entries in this mask change the calculating times being calculated, then the calculation mask opens automatically.

When the interim times are entered manually, the table is created using the entered interim times and a corresponding query appears on closing the interim time matrix.

As an option, the entries for every program can be activated separately with a password query (not when calculation is active). The procedure and password are available on request.

Note:

If the interim times have been calculated and changes are made in this mask, the following message appears:

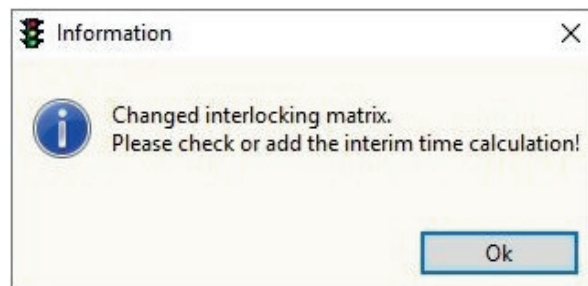

Confirming with **OK** automatically opens the entry mask for interim time calculation.

6.2.2 Interim time calculation

If manual interim time input has been activated, this entry mask is disabled and a corresponding message appears.

This mask cannot be opened if there are no data in the hostilities table.

A corresponding message appears.

The entries in the hostilities table form the number of clearances to be calculated.

The individual lines of the calculation are shown in white and grey for greater clarity.

Signal device designation					Clearance time (tr)				Entry time		Tü	Interim time			
No.	End Green	Lane ID (C)	Start Green	Lane ID (E)	Crossing distance in meters	Vehicle length in meters	Clearance distance in meters	Clearance speed	Time in sec.	Entry distance in meters	Entry speed	Time in sec.	Crossing time in secs.	Tz calculated in secs.	Tz selected in secs.
1	K1		K2		0,00	6	0,00	30 km/h	0,000	0,00	40 km/h	0,000	4	0,000	0
2	K1		K3		0,00	6	0,00	30 km/h	0,000	0,00	40 km/h	0,000	4	0,000	0
3	K2		K1		0,00	6	0,00	30 km/h	0,000	0,00	40 km/h	0,000	4	0,000	0
4	K2		K3		0,00	6	0,00	30 km/h	0,000	0,00	40 km/h	0,000	4	0,000	0
5	K3		K1		0,00	6	0,00	30 km/h	0,000	0,00	40 km/h	0,000	4	0,000	0
6	K3		K2		0,00	6	0,00	30 km/h	0,000	0,00	40 km/h	0,000	4	0,000	0

Fixed values such as signal group name, clearance speeds etc. are taken automatically from the master data. Only the crossing distance and possibly the entry distance have to be entered for each particular calculation.

The values for crossing distance and entry distance can be entered as decimals. In this case, the entry must use the format number, comma, number (100,25).

Other characters will be treated as an error and a corresponding message appears.

As soon as a value for crossing distance is entered for a group, the calculated interim time for clearance appears immediately in the box **Tz** selected in secs.

The active input box is marked in blue.

When calculating more than two signal groups (crossing traffic flows), RiLSA stipulates the need to include vehicle lengths as well.

To include these in the calculation, the option **with vehicle lengths** has to be activated in the main window under **Interim time calculation**. Changes to the number of signal groups in the main mask (more than two groups) trigger an automatic query whether calculation with vehicle lengths should be activated. On reducing the number of signal groups (to less than three groups), a query appears whether calculation with vehicle lengths should be deactivated again.

Note:

Calculating a pedestrian system must include the vehicle lengths as this refers to crossing traffic flows, even when there are only two groups.

Click on  to see an information display. It shows the current clearance and entry speeds currently being used for clearance together with the calculated interim time.

Interim time calculation according to RiLSA															
Signal device designation					Clearance time (tr)				Entry time		Tü	Interim time			
No.	End Green	Lane ID (C)	Start Green	Lane ID (E)	Crossing distance in meters	Vehicle length in meters	Clearance distance in meters	Clearance speed	Time in sec.	Entry distance in meters	Entry speed	Time in sec.	Crossing time in secs.	Tz calculated in secs.	Tz selected in secs.
1	K1		K2		100,00	6	106,00	30 km/h	12,720	0,00	40 km/h	0,000	4	16,720	17
Interim time calculation (K1)					Calculated Tz 16,720 sec. / Selected Tz 17 sec.										
Group 1 (K1) clear with 30 km/h (8,333 m/s)															
5	K3		K1		0,00	6	0,00	30 km/h	0,000	0,00	40 km/h	0,000	4	0,000	0
6	K3		K2		0,00	6	0,00	30 km/h	0,000	0,00	40 km/h	0,000	4	0,000	0

On closing the mask, a test program starts automatically and reports any errors or changes in an existing intersection time plan. It also checks whether all groups have been calculated. If this is not the case, the following message appears:

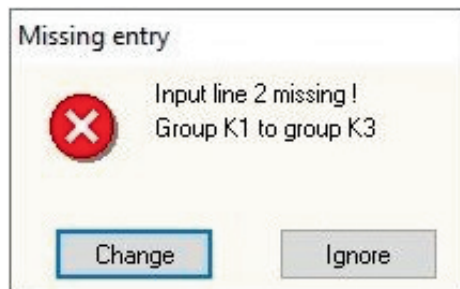

Confirmation with **Ignore** closes the calculation mask with missing data. Confirmation with **Change** jumps to the input box where entries are missing. If several entries are missing these are shown successively and must be confirmed individually.

6.2.2.1 Changing vehicle length

Click the right mouse button on **Vehicle length** in the current calculation to see a menu for changing the vehicle length. This function is only enabled if the mouse cursor is on the clearance speed box.

Interim time calculation according to RiLSA															
Signal device designation					Clearance time (tr)				Entry time		Tu	Interim time			
No.	End Green	Lane ID (C)	Start Green	Lane ID (E)	Crossing distance in meters	Vehicle length in meters	Clearance distance in meters	Clearance speed	Time in sec.	Entry distance in meters	Entry speed	Time in sec.	Crossing time in secs.	Tz calculated in secs.	Tz selected in secs.
1	K1		K2		100,00				0,00	0,00	40 km/h	0,000	4	16,720	17
2	K1		K3		0,00				0,00	0,00	40 km/h	0,000	4	0,000	0
3	K2		K1		0,00				0,00	0,00	40 km/h	0,000	4	0,000	0
4	K2		K3		0,00	6	0,00	30 km/h	0,000	0,00	40 km/h	0,000	4	0,000	0
5	K3		K1		0,00	6	0,00	30 km/h	0,000	0,00	40 km/h	0,000	4	0,000	0
6	K3		K2		0,00	6	0,00	30 km/h	0,000	0,00	40 km/h	0,000	4	0,000	0

- Standard values**
 Click here to enter the default standard value from the signal group master data for the selected group.
- Change values**
 Click here to open the following mask:

The window shows the group name of the selected group. The current value for this group appears as default in the vehicle length box.

To change the vehicle length, enter the required value using the keyboard or press the up/down arrows. **OK** saves the changes.

Note:

If the vehicle length is changed, this value is used to calculate the current clearance, but not for other calculations in this group.

6.2.2.2 Change clearance speed

Click the right mouse button on **Clearance speed** in the current calculation to see a menu for changing the clearance speed. This function is only enabled if the mouse cursor is on the clearance speed box.

Signal device designation		Clearance time (tr)			Entry time		Tü	Interim time							
No.	End Green	Lane ID (C)	Start Green	Lane ID (E)	Crossing distance in meters	Vehicle length in meters	Clearance distance in meters	Clearance speed	Time in sec.	Entry distance in meters	Entry speed	Time in sec.	Crossing time in secs.	Tz calculated in secs.	Tz selected in secs.
1	K1		K2		100,00	6	106,00	30 km/h	13,730	0,00	40 km/h	0,000	4	16,720	17
2	K1		K3		0,00	6	0,00	30				0,000	4	0,000	0
3	K2		K1		0,00	6	0,00	30				0,000	4	0,000	0
4	K2		K3		0,00	6	0,00	30 km/h	0,000	0,00	40 km/h	0,000	4	0,000	0
5	K3		K1		0,00	6	0,00	30 km/h	0,000	0,00	40 km/h	0,000	4	0,000	0
6	K3		K2		0,00	6	0,00	30 km/h	0,000	0,00	40 km/h	0,000	4	0,000	0

- Standard values**
 Click here to enter the default standard value from the signal group master data for the selected group.
- Change values**
 Click here to open the following mask:

The window shows the group name of the selected group. The current value for this group appears as default in the clearance speed box.

The clearance speed is changed by overwriting the default.

OK adopts the changes.

Note:

If the clearance speed is changed, this value is used to calculate the current clearance, but not for other calculations in this group.

6.2.2.3 Changing the entry speed

Click the right mouse button on **Entry speed** of a group to see a menu for changing the entry speed.

This function is only enabled if the mouse cursor is on the entry speed box and the function with entry times is enabled in the program settings.

Signal device designation		Clearance time (tr)				Entry time		Tu	Interim time						
No.	End Green	Lane ID (C)	Start Green	Lane ID (E)	Crossing distance in meters	Vehicle length in meters	Clearance distance in meters	Clearance speed	Time in sec.	Entry distance in meters	Entry speed	Time in sec.	Crossing time in sec.	Tz calculated in sec.	Tz selected in sec.
1	K1		K2		100,00	6	106,00	30 km/h	12,720	0,00	40	0,000	4	0,000	17
2	K1		K3		0,00	6	0,00	30 km/h	0,000	0,00	4	0,000	4	0,000	0
3	K2		K1		0,00	6	0,00	30 km/h	0,000	0,00	4	0,000	4	0,000	0
4	K2		K3		0,00	6	0,00	30 km/h	0,000	0,00	40 km/h	0,000	4	0,000	0
5	K3		K1		0,00	6	0,00	30 km/h	0,000	0,00	40 km/h	0,000	4	0,000	0
6	K3		K2		0,00	6	0,00	30 km/h	0,000	0,00	40 km/h	0,000	4	0,000	0

- Standard values**
 Click here to enter the default standard value from the program settings for the selected group.
- Change values**
 Click here to open the following mask:

The box shows the group name of the selected group. The current value for this group appears as default in the entry speed box.

The entry speed is changed by overwriting the default. **OK** saves the changes.

Note:

If the entry speed is changed, this value is used to calculate the current clearance, but not for other calculations in this group.

6.2.2.4 Changing the Tc time

Click the right mouse button on **Tc time** (crossing time) of a group to see a menu for changing the Tc time.

This function is only enabled if the mouse cursor is on the **Tc time** speed box.

Interim time calculation according to RiLSA															
Signal device designation					Clearance time (tr)				Entry time			Tü	Interim time		
No.	End Green	Lane ID (C)	Start Green	Lane ID (E)	Crossing distance in meters	Vehicle length in meters	Clearance distance in meters	Clearance speed	Time in sec.	Entry distance in meters	Entry speed	Time in sec.	Crossing time in secs.	Tz calculated in secs.	Tz selected in secs.
1	K1		K2		100,00	6	106,00	30 km/h	12,720	0,00	40 km/h	0,000	4	16,770	17
2	K1		K3		0,00	6	0,00	30 km/h	0,000	0,00	40 km/h	0,000			
3	K2		K1		0,00	6	0,00	30 km/h	0,000	0,00	40 km/h	0,000			
4	K2		K3		0,00	6	0,00	30 km/h	0,000	0,00	40 km/h	0,000			
5	K3		K1		0,00	6	0,00	30 km/h	0,000	0,00	40 km/h	0,000	4	0,000	0
6	K3		K2		0,00	6	0,00	30 km/h	0,000	0,00	40 km/h	0,000	4	0,000	0

The following possibilities can be selected:

- Standard values**
 Click here to enter the default standard value from the program settings for the selected group.
- Change values**
 Click here to open the following mask:

The current Tc time for the selected group appears as default in this box. **OK** saves the adjusted value for this group.

Note:

If the Tc time is changed, this value is used to calculate the current clearance, but not for other calculations in this group.

6.2.2.5 Increase the calculated value

Double click the left mouse button on **Tz** to increase the value by a second at a time. Manually increased values appear in red. It is **not** possible to reduce the calculated value.

Interim time calculation according to RiLSA															
Signal device designation					Clearance time (tr)				Entry time			TÜ	Interim time		
No.	End Green	Lane ID (C)	Start Green	Lane ID (E)	Crossing distance in meters	Vehicle length in meters	Clearance distance in meters	Clearance speed	Time in sec.	Entry distance in meters	Entry speed	Time in sec.	Crossing time in secs.	Tz calculated in secs.	Tz selected in secs.
1	K1		K2		100,00	6	106,00	30 km/h	12,720	0,00	40 km/h	0,000	4	16,720	18
2	K1		K3		0,00	6	0,00	30 km/h	0,000	0,00	40 km/h	0,000	4	0,000	0
3	K2		K1		0,00	6	0,00	30 km/h	0,000	0,00	40 km/h	0,000	4	0,000	0
4	K2		K3		0,00	6	0,00	30 km/h	0,000	0,00	40 km/h	0,000	4	0,000	0
5	K3		K1		0,00	6	0,00	30 km/h	0,000	0,00	40 km/h	0,000	4	0,000	0
6	K3		K2		0,00	6	0,00	30 km/h	0,000	0,00	40 km/h	0,000	4	0,000	0

Click the right mouse button on **Tz** selected of a group to see the following possibility:

Interim time calculation according to RiLSA															
Signal device designation					Clearance time (tr)				Entry time			TÜ	Interim time		
No.	End Green	Lane ID (C)	Start Green	Lane ID (E)	Crossing distance in meters	Vehicle length in meters	Clearance distance in meters	Clearance speed	Time in sec.	Entry distance in meters	Entry speed	Time in sec.	Crossing time in secs.	Tz calculated in secs.	Tz selected in secs.
1	K1		K2		100,00	6	106,00	30 km/h	12,720	0,00	40 km/h	0,000	4	16,720	18
2	K1		K3		0,00	6	0,00	30 km/h	0,000	0,00	40 km/h	0,000	4	0,000	0
3	K2		K1		0,00	6	0,00	30 km/h	0,000	0,00	40 km/h	0,000	4	0,000	0
4	K2		K3		0,00	6	0,00	30 km/h	0,000	0,00	40 km/h	0,000	4	0,000	0
5	K3		K1		0,00	6	0,00	30 km/h	0,000	0,00	40 km/h	0,000	4	0,000	0
6	K3		K2		0,00	6	0,00	30 km/h	0,000	0,00	40 km/h	0,000	4	0,000	0

Click on **Reset** to reset a manually increased value to the originally calculated value.

Note:

As soon as a value is changed in the calculation, the value for **selected interim time** is updated. The manual increases then no longer apply.

6.2.2.6 Recalculating clearance with the standard values

As soon as one of the values vehicle length, clearance speed, entry speed or crossing time is changed manually during a calculation, the **No.** of the corresponding line is highlighted in colour. The affected boxes are also highlighted in colour.

Interim time calculation according to RiLSA															
Signal device designation					Clearance time (tr)				Entry time			Tü	Interim time		
No.	End Green	Lane ID (C)	Start Green	Lane ID (E)	Crossing distance in meters	Vehicle length in meters	Clearance distance in meters	Clearance speed	Time in sec.	Entry distance in meters	Entry speed	Time in sec.	Crossing time in secs.	Tz calculated in secs.	Tz selected in secs.
1	K1		K2		50,00	9	59,00	30 km/h	7,080	0,00	40 km/h	0,000	4	11,080	12
2	K1		K3		50,00	6	56,00	26 km/h	7,754	0,00	40 km/h	0,000	4	11,754	12
3	K2		K1		50,00	6	56,00	30 km/h	6,720	0,00	45 km/h	0,000	4	10,720	11
4	K2		K3		50,00	6	56,00	30 km/h	6,720	0,00	40 km/h	0,000	6	12,720	13
5	K3		K1		50,00	6	56,00	30 km/h	6,720	0,00	40 km/h	0,000	4	10,720	11
6	K3		K2		50,00	6	56,00	30 km/h	6,720	0,00	40 km/h	0,000	4	10,720	11

Click the right mouse button on the **No.** of a group to see the following possibility:

Interim time calculation according to RiLSA															
Signal device designation					Clearance time (tr)				Entry time			Tü	Interim time		
No.	End Green	Lane ID (C)	Start Green	Lane ID (E)	Crossing distance in meters	Vehicle length in meters	Clearance distance in meters	Clearance speed	Time in sec.	Entry distance in meters	Entry speed	Time in sec.	Crossing time in secs.	Tz calculated in secs.	Tz selected in secs.
2	K1		K3		50,00	6	56,00	26 km/h	7,754	0,00	40 km/h	0,000	4	11,754	12
3	K2		K1		50,00	6	56,00	30 km/h	6,720	0,00	45 km/h	0,000	4	10,720	11
4	K2		K3		50,00	6	56,00	30 km/h	6,720	0,00	40 km/h	0,000	6	12,720	13
5	K3		K1		50,00	6	56,00	30 km/h	6,720	0,00	40 km/h	0,000	4	10,720	11
6	K3		K2		50,00	6	56,00	30 km/h	6,720	0,00	40 km/h	0,000	4	10,720	11

Select this to recalculate the current clearance with the standard values. All manually changed values are then preset to the standard values.

Note:

This possibility only appears for clearance lines where **No.** is highlighted in colour (manually changed values).

6.2.3 Calculating additional lanes

From Ampeltools version 1.50, up to ten clearances can be calculated for each relation. The existing parameters can be used for each clearance.

6.2.3.1 Insert calculation of additional lanes

Click the left mouse button on **End green** of a group to open a selection menu.

The screenshot shows a window titled "Interim time calculation" with a yellow header "Interim time calculation according to RiLSA". Below the header is a table with columns: "Signal device designation", "Clearance time (tr)", "Entry time", "Tü", and "Interim time". The table has 6 rows. A context menu is open over the "End Green" column of row 1, with options: "Insert additional calculation", "Delete marked calculation", and "Close menu".

Signal device designation					Clearance time (tr)				Entry time			Tü	Interim time		
No.	End Green	Lane ID (C)	Start Green	Lane ID (E)	Crossing distance in meters	Vehicle length in meters	Clearance distance in meters	Clearance speed	Time in sec.	Entry distance in meters	Entry speed	Time in sec.	Crossing time in secs.	Tz calculated in secs.	Tz selected in secs.
1	K1		K2		100,00	6	106,00	30 km/h	12,720	0,00	40 km/h	0,000	4	16,720	17
2	K1		K2		0,00	6	0,00	30 km/h	0,000	0,00	40 km/h	0,000	4	0,000	
3	K1		K3		85,00	6	91,00	30 km/h	10,920	0,00	40 km/h	0,000	4	14,920	15
4	K2		K1		95,00	6	101,00	30 km/h	12,120	0,00	40 km/h	0,000	4	16,120	17
5	K2		K3		90,00	6	96,00	30 km/h	11,520	0,00	40 km/h	0,000	4	15,520	16
6	K3		K1		55,00	6	61,00	30 km/h	7,320	0,00	40 km/h	0,000	4	11,320	12
			K2		85,00	6	91,00	30 km/h	10,920	0,00	40 km/h	0,000	4	14,920	15

Click on **Insert additional calculation** to insert an additional calculation line for the selected group. All calculations belonging to a relation are shown in the same colour for greater clarity.

The screenshot shows the same window as above, but now with 7 rows. The "End Green" column of row 1 is highlighted in blue, and a new row (row 7) has been added, also with "End Green" K3. The context menu is no longer visible.

Signal device designation					Clearance time (tr)				Entry time			Tü	Interim time		
No.	End Green	Lane ID (C)	Start Green	Lane ID (E)	Crossing distance in meters	Vehicle length in meters	Clearance distance in meters	Clearance speed	Time in sec.	Entry distance in meters	Entry speed	Time in sec.	Crossing time in secs.	Tz calculated in secs.	Tz selected in secs.
1	K1		K2		100,00	6	106,00	30 km/h	12,720	0,00	40 km/h	0,000	4	16,720	17
2	K1		K2		0,00	6	0,00	30 km/h	0,000	0,00	40 km/h	0,000	4	0,000	
3	K1		K3		85,00	6	91,00	30 km/h	10,920	0,00	40 km/h	0,000	4	14,920	15
4	K2		K1		95,00	6	101,00	30 km/h	12,120	0,00	40 km/h	0,000	4	16,120	17
5	K2		K3		90,00	6	96,00	30 km/h	11,520	0,00	40 km/h	0,000	4	15,520	16
6	K3		K1		55,00	6	61,00	30 km/h	7,320	0,00	40 km/h	0,000	4	11,320	12
7	K3		K2		85,00	6	91,00	30 km/h	10,920	0,00	40 km/h	0,000	4	14,920	15

Note:

On reaching the maximum number of ten additional calculations for a relation, the **Insert additional calculation** function is disabled.

6.2.3.2 Calculate additional lanes

After inserting additional clearances, the corresponding calculations are carried out. If there is more than one calculation for a relation, a lane ID has to be entered for these calculations. These serve for greater clarity so that the individual calculations can be allocated to a relation.

Interim time calculation according to RiLSA															
Signal device designation					Clearance time (tr)				Entry time			Tu	Interim time		
No.	End Green	Lane ID (C)	Start Green	Lane ID (E)	Crossing distance in meters	Vehicle length in meters	Clearance distance in meters	Clearance speed	Time in sec.	Entry distance in meters	Entry speed	Time in sec.	Crossing time in secs.	Tz calculated in secs.	Tz selected in secs.
1	K1	Right	K2	Straight	85,00	6	91,00	30 km/h	10,920	0,00	40 km/h	0,000	4	14,920	
2	K1	Straight	K2	Straight	87,25	6	93,25	30 km/h	11,190	0,00	40 km/h	0,000	4	15,190	16
3	K1	Left	K2	Straight	86,25	6	92,25	30 km/h	11,070	0,00	40 km/h	0,000	4	15,070	
4	K1		K3		85,00	6	91,00	30 km/h	10,920	0,00	40 km/h	0,000	4	14,920	15
5	K2		K1		95,00	6	101,00	30 km/h	12,120	0,00	40 km/h	0,000	4	16,120	17
6	K2		K3		90,00	6	96,00	30 km/h	11,520	0,00	40 km/h	0,000	4	15,520	16
7	K3		K1		55,00	6	61,00	30 km/h	7,320	0,00	40 km/h	0,000	4	11,320	12
8	K3		K2		85,00	6	91,00	30 km/h	10,920	0,00	40 km/h	0,000	4	14,920	15

If several clearances have been calculated for a relation, the highest value is taken as selected interim time and appears in the interim time matrix. The highest value of several clearances for a relation is shown in the corresponding clearance line.

Note:

When the mask is closed, the system checks whether a lane ID has been entered for all clearances of a relation. If this is not the case, the following message appears:

Interim time calculation according to RiLSA															
Signal device designation					Clearance time (tr)				Entry time			Tu	Interim time		
No.	End Green	Lane ID (C)	Start Green	Lane ID (E)	Crossing distance in meters	Vehicle length in meters	Clearance distance in meters	Clearance speed	Time in sec.	Entry distance in meters	Entry speed	Time in sec.	Crossing time in secs.	Tz calculated in secs.	Tz selected in secs.
1	K1	Right	K2	Straight	85,00	6	91,00	30 km/h	10,920	0,00	40 km/h	0,000	4	14,920	
2	K1		K2	Straight	87,25	6	93,25	30 km/h	11,190	0,00	40 km/h	0,000	4	15,190	16
3	K1	Left	K2	Straight	86,50	6	92,50	30 km/h	11,100	0,00	40 km/h	0,000	4	15,100	
4	K1		K3		0,00	6	0,00	30 km/h	0,000	0,00	40 km/h	0,000	4	0,000	0
5	K2		K1		0,00	6	0,00	30 km/h	0,000	0,00	40 km/h	0,000	4	0,000	0
6	K2		K3		0,00	6	0,00	30 km/h	0,000	0,00	40 km/h	0,000	4	0,000	0
7	K3		K1		0,00	6	0,00	30 km/h	0,000	0,00	40 km/h	0,000	4	0,000	0
8	K3		K2		0,00	6	0,00	30 km/h	0,000	0,00	40 km/h	0,000	4	0,000	0

Confirm with **Ignore** to close the calculation mask despite the missing data. Confirm with **Change** to go to the input box where the entry is missing. If several entries are missing these are shown successively and must be confirmed individually.

6.2.3.3 Remove calculation of additional lanes

Click the left mouse button on **End green** of a group to open a selection menu.

Interim time calculation according to RiLSA															
Signal device designation					Clearance time (tr)				Entry time		Tu	Interim time			
No.	End Green	Lane ID (C)	Start Green	Lane ID (E)	Crossing distance in meters	Vehicle length in meters	Clearance distance in meters	Clearance speed	Time in sec.	Entry distance in meters	Entry speed	Time in sec.	Crossing time in secs.	Tz calculated in secs.	Tz selected in secs.
1	K1	Right	K2	Straight	85,00	6	91,00	30 km/h	10,920	0,00	40 km/h	0,000	4	14,920	
2	K1	Straight	K2	Straight	87,25	6	93,25	30 km/h	11,190	0,00	40 km/h	0,000	4	15,190	16
3				Straight	86,25	6	92,25	30 km/h	11,070	0,00	40 km/h	0,000	4	15,070	
4					85,00	6	91,00	30 km/h	10,920	0,00	40 km/h	0,000	4	14,920	15
5					95,00	6	101,00	30 km/h	12,120	0,00	40 km/h	0,000	4	16,120	17
6					90,00	6	96,00	30 km/h	11,520	0,00	40 km/h	0,000	4	15,520	16
7	K3		K1		55,00	6	61,00	30 km/h	7,320	0,00	40 km/h	0,000	4	11,320	12
8	K3		K2		85,00	6	91,00	30 km/h	10,920	0,00	40 km/h	0,000	4	14,920	15

Delete marked calculation deletes the marked calculation line. If the deleted calculation line included the highest interim time, the highest value of the remaining lines is now taken as selected interim time.

Interim time calculation according to RiLSA															
Signal device designation					Clearance time (tr)				Entry time		Tu	Interim time			
No.	End Green	Lane ID (C)	Start Green	Lane ID (E)	Crossing distance in meters	Vehicle length in meters	Clearance distance in meters	Clearance speed	Time in sec.	Entry distance in meters	Entry speed	Time in sec.	Crossing time in secs.	Tz calculated in secs.	Tz selected in secs.
1	K1	Right	K2	Straight	85,00	6	91,00	30 km/h	10,920	0,00	40 km/h	0,000	4	14,920	
2	K1	Left	K2	Straight	86,25	6	92,25	30 km/h	11,070	0,00	40 km/h	0,000	4	15,070	16
3	K1		K3		85,00	6	91,00	30 km/h	10,920	0,00	40 km/h	0,000	4	14,920	15
4	K2		K1		95,00	6	101,00	30 km/h	12,120	0,00	40 km/h	0,000	4	16,120	17
5	K2		K3		90,00	6	96,00	30 km/h	11,520	0,00	40 km/h	0,000	4	15,520	16
6	K3		K1		55,00	6	61,00	30 km/h	7,320	0,00	40 km/h	0,000	4	11,320	12
7	K3		K2		85,00	6	91,00	30 km/h	10,920	0,00	40 km/h	0,000	4	14,920	15

If hostilities are deleted in the **interlocking matrix**, all existing clearances for this relation are also deleted.

Note:

Delete marked calculation is only enabled if the selected relation has several clearances.

6.2.4 Interim time matrix

Depending on the setting in the main menu, the interim time matrix is either calculated or entered manually.
The appearance of the mask changes according to the setting.

6.2.4.1 Take interim time matrix from interim time calculation

Once the interim times have been calculated, the results are transferred automatically to the interim time matrix on closing the calculation mask with **OK**.
Manual changes are not possible in this mask.

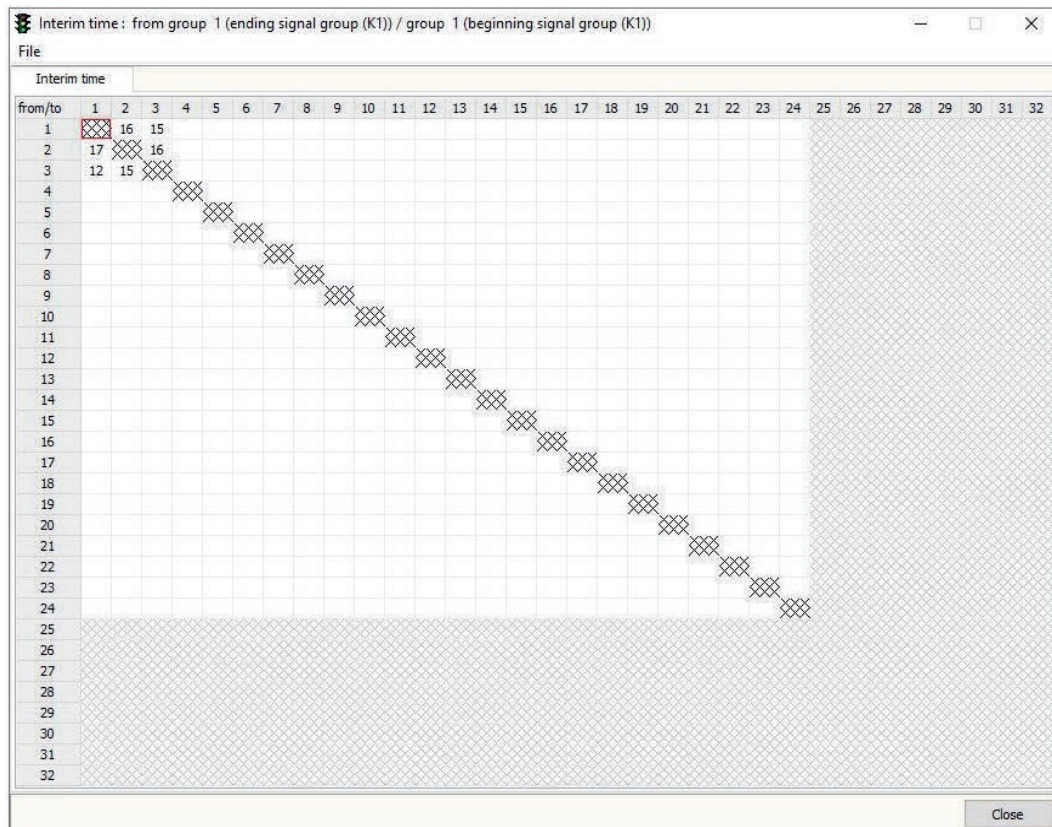

Note:

If the interim time matrix is open, it is also updated when the calculation mask is closed with **OK**.

6.2.4.2 Manual input in the interim time matrix

If manual input in the interim time matrix is activated, the entry functions are enabled. The corresponding entries can be made. The entries are adjusted to the selected controller type / version. Boxes that are not needed are disabled and shown cross-hatched. The entry is limited to 99 seconds, depending on the version.

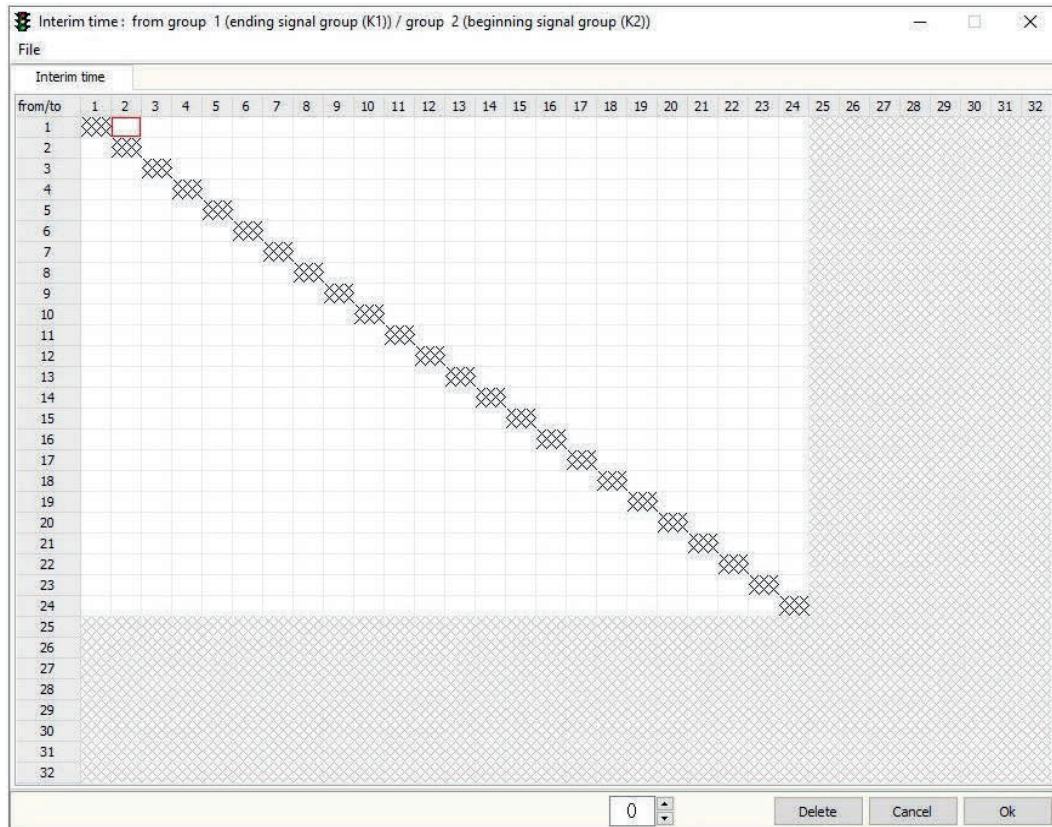

The interim times are entered line by line, i.e. in the first line, the interim times are entered for group 1 (ending group) to the other groups (starting groups).

The interim times for group 2 to the other groups are entered in the second line, etc.

The value entered in a line states the time that has to be met from the end of green for the ending group to the start of green for the starting group.

On falling below one of these times, the current program is stopped immediately due to an interim time error.

The values in the interim time matrix are used for all released programs.

Note

As an option, the entries for every program can be activated separately with a password query. The procedure and password are available on request.

6.2.4.3 Asymmetrical interim time matrix

While the interim times are being entered, the system checks whether they are symmetrical. Asymmetrical entries are highlighted in colour in the corresponding boxes. As soon as a value is entered in a box highlighted in colour, the corresponding marking disappears again. It is not possible to close the window with asymmetrical entries.

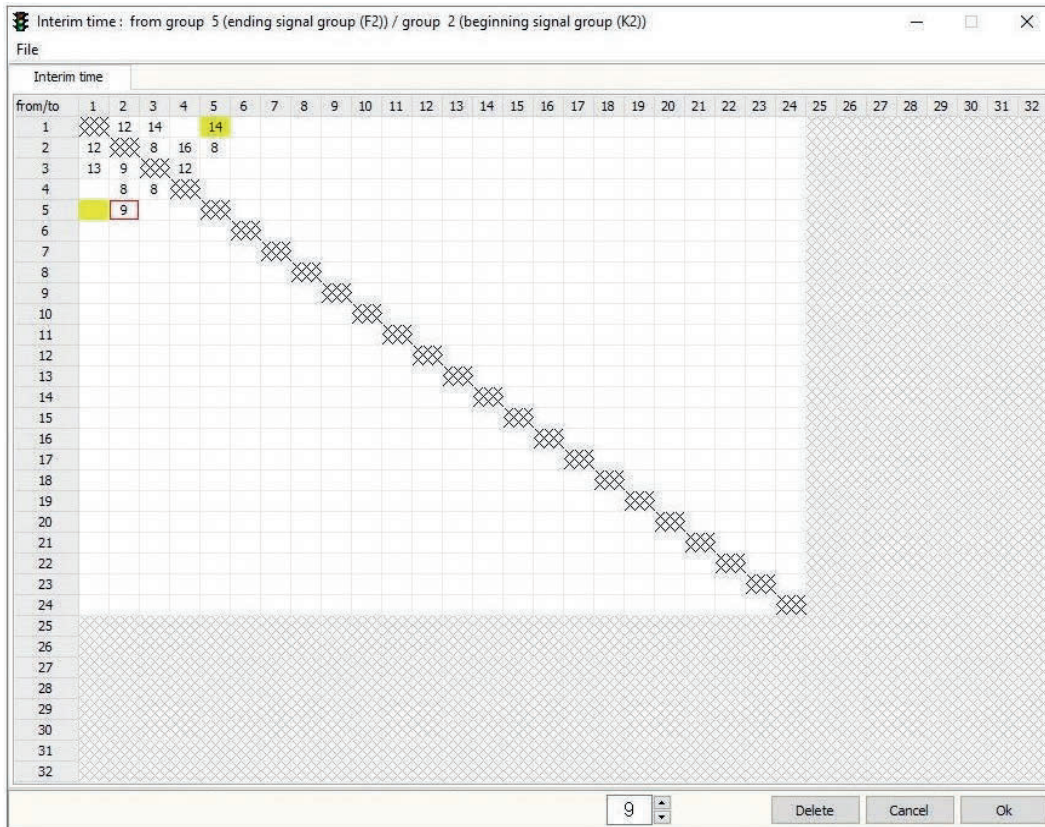

6.2.4.4 Create interlocking matrix automatically

When entries or changes are made to the interim time matrix, a query appears on closing the window to confirm whether the corresponding interlocking matrix should be updated.

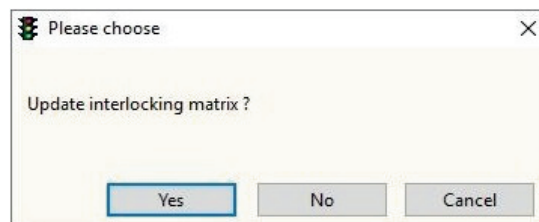

The interlocking matrix is created or updated depending on the confirmation.

6.3 Create a program

This menu point features all functions of various entry masks for creating the actual signal programs.

6.3.1 Determine cycle time and green phases according to traffic flow

This function can be used to create intersection time plans automatically for bottleneck signal systems.

The calculation principles correspond to the formulas in RiLSA 2010.

Note:

This menu point can only be selected if the number of groups is two and the corresponding interim times are available.

6.3.1.1 Enter traffic flows

The respective traffic flows per group are entered in this entry mask for each released program (in vehicles per hour - VPH).

The current interim times matrix appears as well as the calculation results.

from/to	1	2
1	16	16
2	16	16

The cycle times and green phases are then determined automatically using these values. The calculated cycle time appears in **Cycle time**.

Selected cycle time shows the calculated cycle time rounded up to the full second.

Use the up/down arrows after the cycle time display to adjust the cycle time manually.

The green phases are automatically calculated again if the cycle time is changed.

Note:

This mask opens automatically as soon as it contains any data and the interim times or min. release times have been changed in the master data.

6.3.1.2 Change saturation flow

The saturation flows for calculating cycle times and green phases are stated as 1,500 vehicles per hour (default from RiLSA 2010).

Use the **Edit** option to change this for the respective program.

6.3.1.3 Create intersection time plans automatically according to traffic flow

If the mask for creating program with traffic flows is closed, the following query appears:



The intersection time plans are then created automatically, depending on the confirmation. On creating the intersection time plans as vehicle-actuated program, an extension point is always set one second before green end. The default time gap is 5 seconds. The minimum release time corresponds to the time entered in the signal group master data. The intersection time plan then opens automatically to check the intersection time plans.

Note:

The signal time plans are created for all released programs according to the calculated data.

6.3.2 Automatic intersection time plans

The entries are adjusted to the selected controller type / version. Boxes that are not needed are disabled and shown cross-hatched.

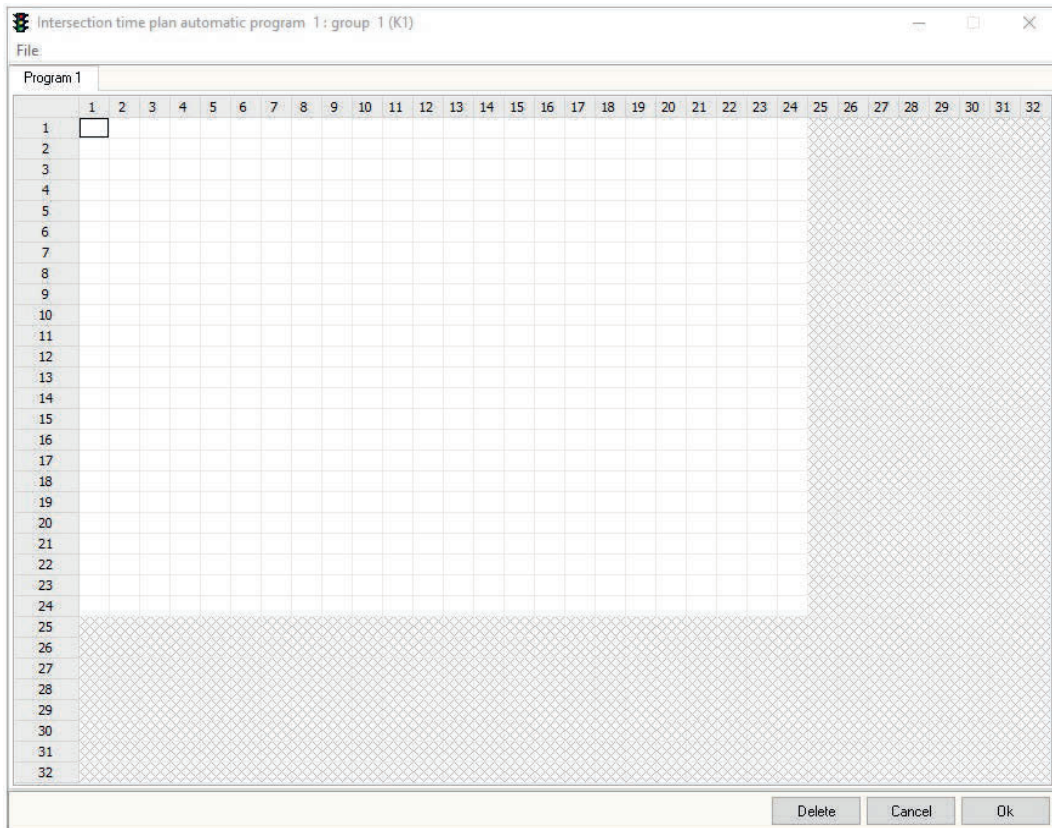

This mask can be used to stipulate a basic procedure for the intersection time plan editor. A basic program is created based on the entered basic data. Hostile groups cannot be entered together in one line.

Note:

This function is not yet available.

6.3.3 Intersection time plan editor

Selecting this function opens an editor for graphic input of the intersection time plans. The scope of the intersection time plan editor is adjusted to the functions of the Berghaus controllers (EPB / MPB4xxx series).

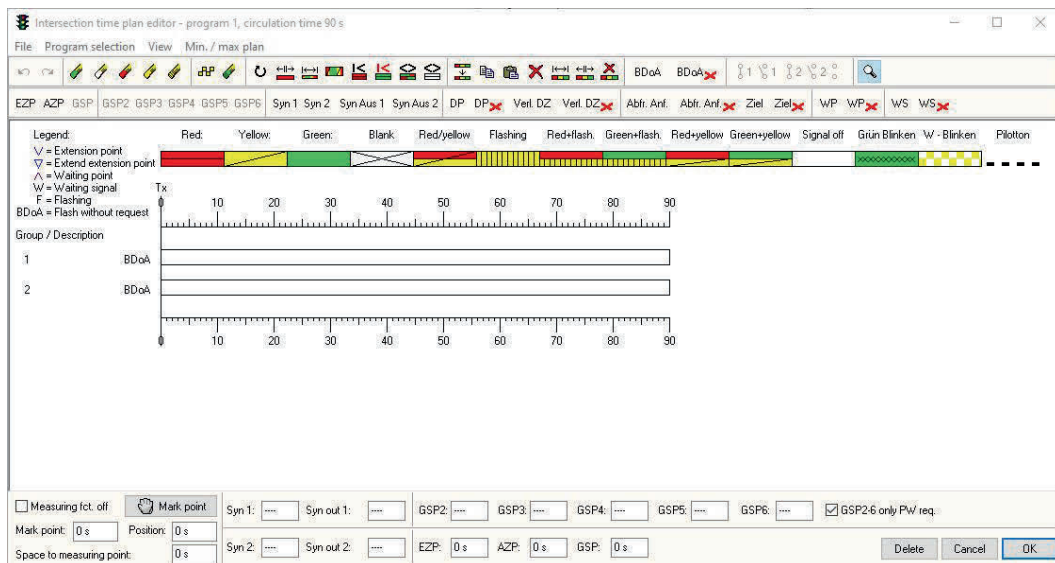

Note:

If the intersection time plan editor is closed with **OK**, the system checks whether an intersection time plan has been created for all released programs. If this is not the case, the following query appears:

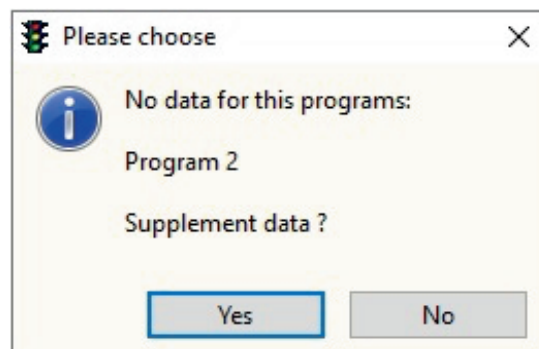

Depending on the confirmation, the intersection time plan editor is closed and the data are adopted or it remains open for corrections.

6.3.3.1 Working with the intersection time plan editor

Click on the individual buttons to open the respective drawing/program functions.

The system always only draws the pure green, blank or green arrow phases.

The red-yellow and yellow phases are inserted automatically from the master data and the remaining phases are automatically filled with red.

While the system is drawing or processing the intersection time plan, it is checked automatically for interim time errors.

Depending on controller type, drawing is possible twice per group (not MPB4xxx).

The depiction of the mouse cursor changes according to the selected function.

As soon as the mouse cursor is within a signal group, a window appears and the mouse is moved accordingly.

Various values are shown together with any possible errors in the currently active group.



```
Green (15)
from 1 to 16
Group 1
Position 16 s
```

Press  for the **Undo** function. This lets you undo the last actions.

Press  for the **Restore** function. This lets you restore the last undone actions.

Note:

If you change to another program in the meantime, any changes to previously edited programs are also shown in this list.

Click on  (thus locking the button) to see the following phases for the groups in the intersection time plan:

- Green start
- Green end
- Continuous green
- Red-yellow start
- Yellow end

Note:

The display of the actual green phase is automatically hidden as soon as interim time errors or hostility errors are ascertained.

6.3.3.2 Intersection time plan editor settings

The following settings can be adjusted in the menu under **View**:

- Display of green from, green to, continuous green, yellow and red-yellow phases.
- In addition, the single-second interval can be adjusted in 3 stages.

The header of the intersection time plan editor shows the current program, the program name, the cycle time and other information about the current program. The size of this window can be changed for greater clarity.

When the intersection time plan editor is closed, the following settings are saved:

- Show phases (green from, green to, continuous green, yellow and red-yellow phases).
- Single-second interval setting
- Measuring function on or off
- Editor window size.

These functions are preset accordingly every time the intersection time plan editor is opened.

Note:

Program selection is only enabled if several programs have been released.

6.3.3.3 Intersection time plan editor displays

Various symbols/displays appear in the intersection time plan editor, depending on the selected function.

Firstly, a number appears to the left of the intersection time plan, followed by the group name. **F** appears after the group name if the group has an error or if the controller has been switched to flashing. **BDoA** appears if flashing/continuous yellow without request has been activated for this group. **6.3.6.7**

If an extension point has been inserted for a group, this is marked with a symbol (V pointing downwards) above this group. If the function **Extend extension point** is activated, the symbol appears closed. The symbol (V pointing upwards) under a group marks a manual lock-in point for this group.

If a **W** appears within the green phase for a group, the waiting signal function has been activated for this group.

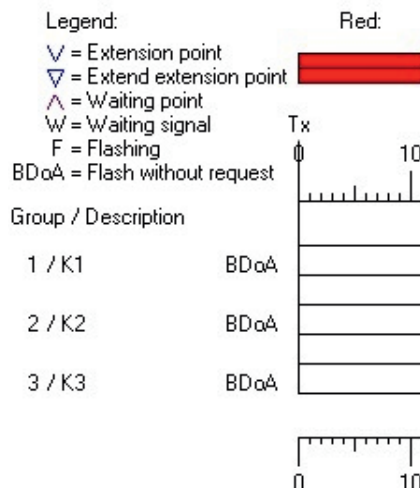

6.3.3.4 Automatic interim time check

While drawing or processing groups, the system checks automatically for interim time errors / hostile green.

All hostilities of the currently active groups are shown in the window that appears at the mouse cursor. If **O** appears as well, this means overlap (hostile groups have green at the same time). In addition, the hostilities to other groups are shown at the start of every group.

Note:

OK is disabled when program errors are detected. It is not enabled again until all errors have been eliminated.

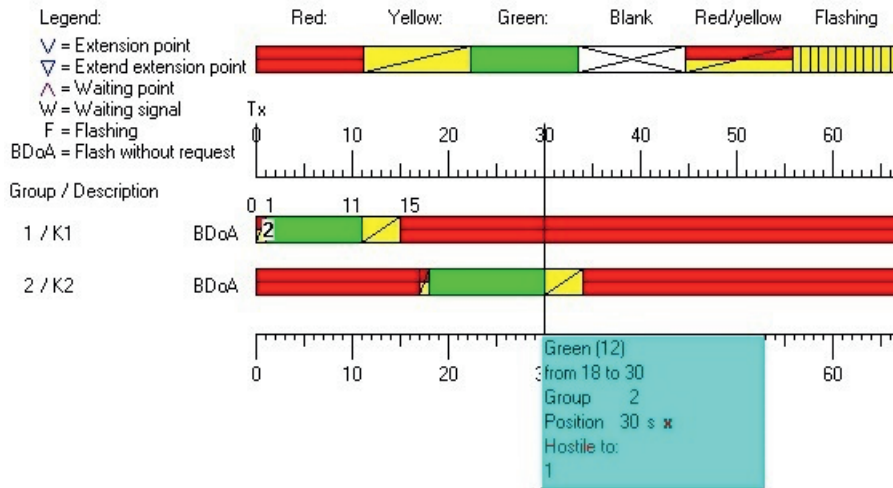

Note:

The interim time check also starts automatically always after the following functions:

- Loading or importing data
- Closing the **Calculate clearance times** window or the interim time matrix.
- Changes in the calculation settings of a mask change the interim times so that these are undercut.

On detecting errors, the intersection time plan editor opens immediately with a corresponding error list.

6.3.3.5 Measuring function

The bottom left section of the intersection time plan editor contains the control elements and measuring function displays. These can be used to ascertain distances within the intersection time plan.

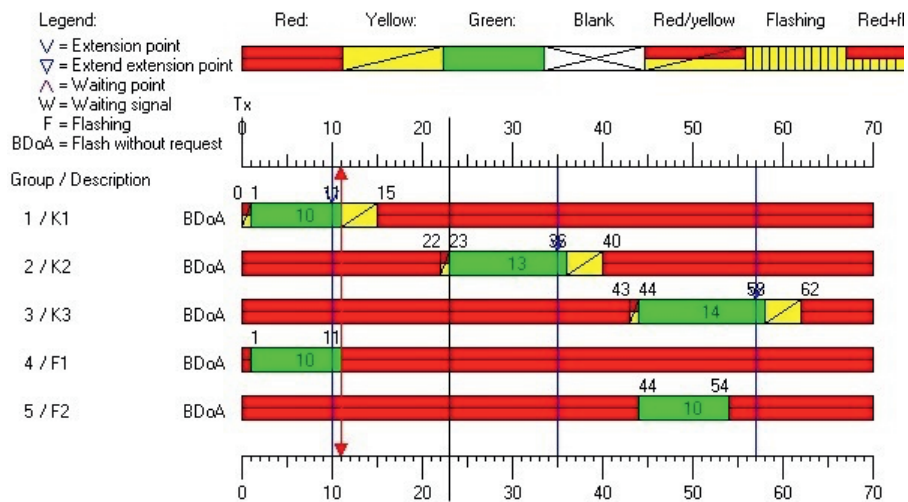

<input type="checkbox"/> Measuring fct. off	<input checked="" type="button" value="Mark point"/>	Syn 1: <input type="text" value="...."/>	Syn out 1: <input type="text" value="...."/>	GSP2: <input type="text" value="...."/>	GSP3: <input type="text" value="...."/>
Mark point: <input type="text" value="11 s"/>	Position: <input type="text" value="23 s"/>	Syn 2: <input type="text" value="...."/>	Syn out 2: <input type="text" value="...."/>	EZP: <input type="text" value="0 s"/>	AZP: <input type="text" value="0 s"/>
Space to measuring point: <input type="text" value="12 s"/>					

Displays:

A ruler (black line) can be used to mark every single second of the signal time plan in the specific program. The current position of the ruler is shown after **Position**.

Measuring point shows the second at which the measuring point has been set (this appears as a red line in the intersection time plan).

Distance to measuring point shows the difference to the set measuring point and the position of the ruler.

Control elements:

The **Measuring point** box switches the measuring function on or off.

Clicking on **Set measuring point** shows the measuring line and places it on the current cursor position. As soon as the position of the ruler changes, the corresponding values are updated in the respective displays.

6.3.3.6 Drawing mode

If the fluid drawing function has been selected, the selected phase (colour) is filled in automatically while drawing.

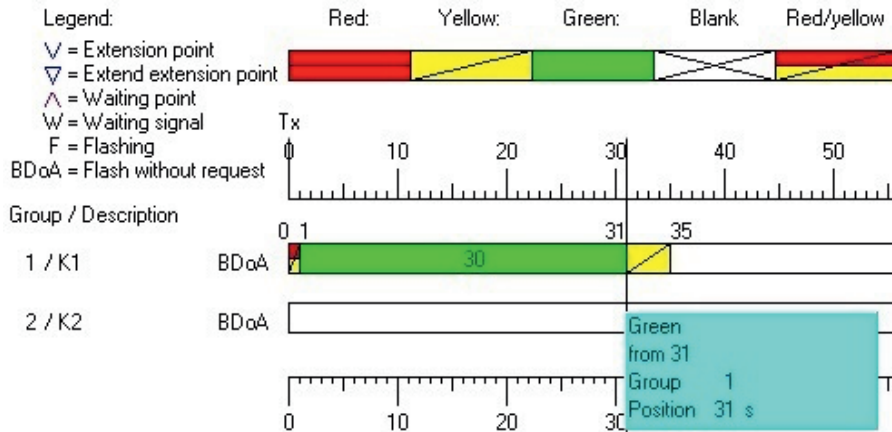

If fluid drawing is disabled, only the start time is selected.

After defining the end time, the active group is drawn with the corresponding phases (colours).

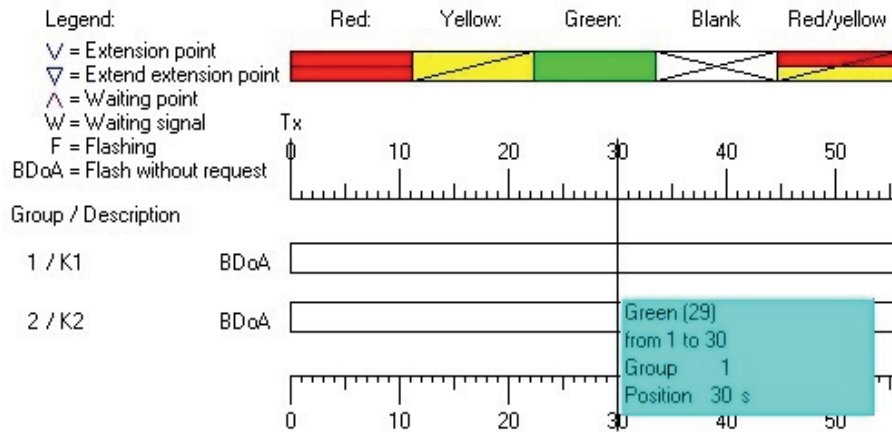

If the automatic filling function is activated, the red phase is inserted automatically while drawing.

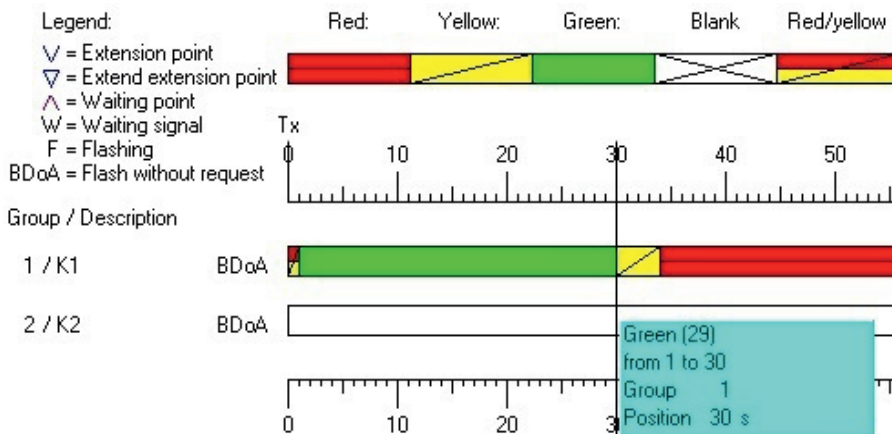

If the automatic filling function is disabled, only the selected phase (colour) and the red-yellow and yellow-phases are shown (if present).

The function for filling the intersection time plan fills the rest of the phase with red.

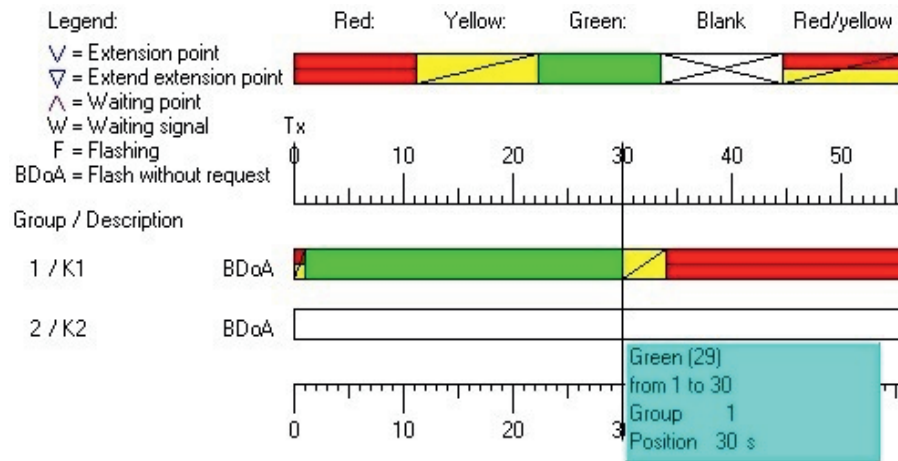

6.3.3.7 Load / save draft

From Ampeltools version 2.0, these functions can now only be selected in the „File“ menu of the intersection time plan editor.

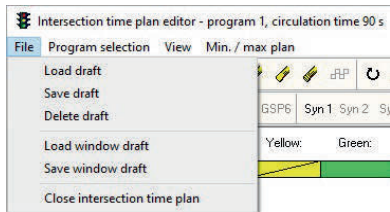

Saving a draft only saves the signal time plan data for all released programs but **not** any other data! To save all data, please use the Save data function in the main window. To load a draft for which data already exist in the intersection time plan, a query appears whether these should be overwritten.

Note:

Loading a draft updates the data in all released programs!

6.3.3.8 Load / save window draft

From Ampeltools version 2.0, these functions can now only be selected in the „File“ menu of the intersection time plan editor.

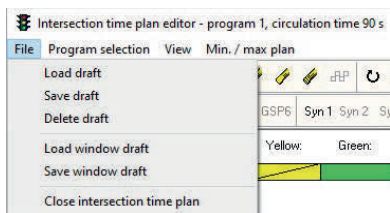

Saving a window draft only saves the signal time plan data of the currently visible program but **not** any other data! To save all data, please use the Save data function in the main window. To load a window draft for which data already exist in the intersection time plan, a query appears whether these should be overwritten.

Note:

Loading a window draft updates **only** the data in the currently visible program!

6.3.3.9 View min/max intersection time plan

Min / Max Plan can be used to change the display between minimum and maximum cycle.

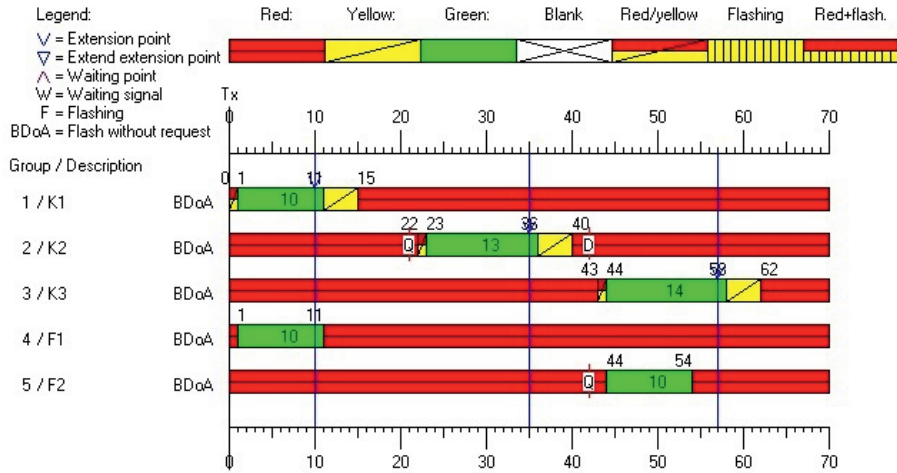

View of max. intersection time plan:

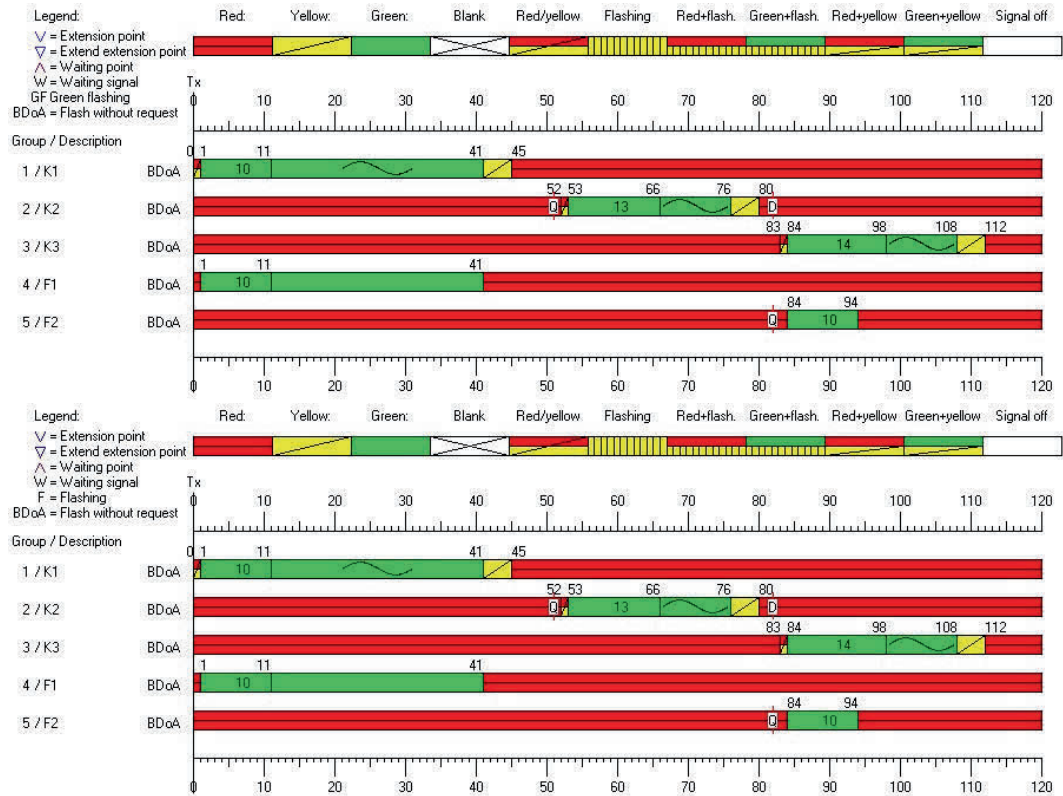

Note:

The intersection time plans cannot be edited in the maximum cycle view. All editing functions are disabled.

6.3.4 Create intersection time plan

The intersection time plan editor is used for graphic creation of the individual programs. When drawing a first start-up, there is one second minimum disable time until the second start-up.
Red exception is the combination of blank and green within a group.

Note:

All controllers in the EPB series support two start-ups per group in a cycle for all times. Controller type MPB4xxx only supports one start-up for each cycle.

6.3.4.1 Draw green phase

Clicking on  activates the **Draw green phase** function, which locks when selected. The green phase or a green arrow is drawn, depending on the settings of the signal group type in the master data.

Use the mouse to select the required group and mark the start time with the first mouse click (left button).

On reaching the required end position, confirm this again with another left mouse click.

The drawn time is then shown for the current group.

Information about the current group appears at the current mouse position for greater clarity.

There can be various causes when a lock symbol appears while drawing:

- Min. release time still undercut.
- A second green phase has already been drawn or only one is supported.
- Green phase and green arrow cannot be drawn together in one group.
- Selected function not possible in the current cycle second, e.g. request query in red-yellow.

Note:

While drawing a group, the system checks automatically for interim time errors to other groups.

6.3.4.1.1 Draw green phase

When a green phase is drawn, the red-yellow and yellow phases are filled in for the group automatically from the master data.

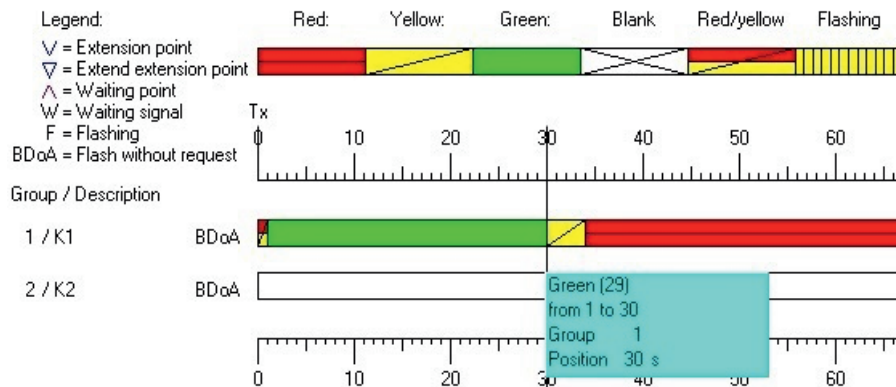

Note:

If the **Green flashing** function has been activated for a signal group (6.1.5), when drawing the green phase this is shown graphically as green flashing. The corresponding signal groups then flash green for the drawn green phase. See point 6.3.4.1.4 for variable drawing of the green phase, e.g. just the last four seconds

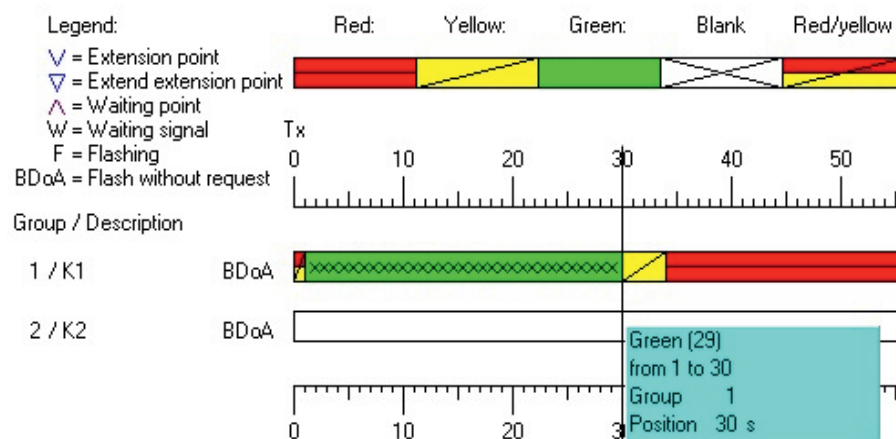

6.3.4.1.2 Draw green arrow

When a green arrow is drawn, the red-yellow and yellow phases are filled in for the group automatically from the master data (standard default 0/5 seconds). However, the following differences appear when drawing a green arrow compared to drawing green phases:

- The remaining time is not filled in with red.

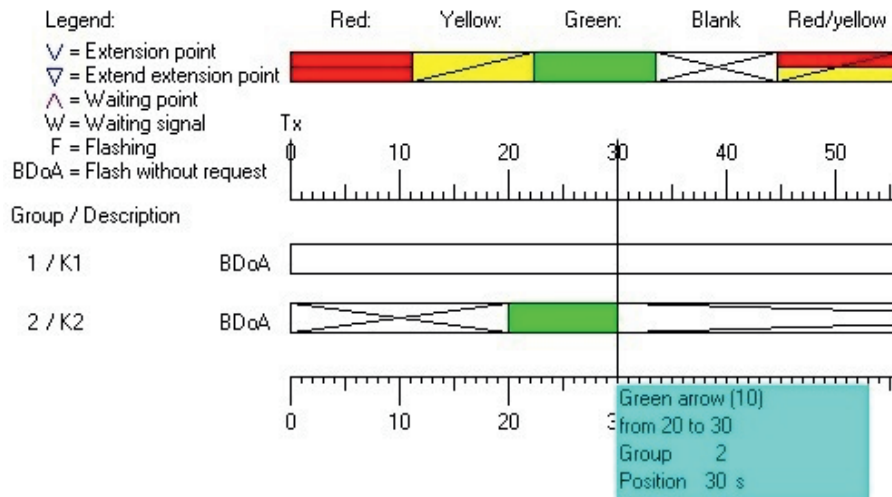

Note:

For groups declared to be green arrows, no other times can be drawn apart from continuous yellow and flashing.

Red lamp monitoring is to be disabled for these groups, depending on controller type and version.

6.3.4.1.3 Draw continuous green

The continuous green function can be drawn for every signal group type.

To draw a continuous green phase, the green start is set at second 0 and the mouse is then pulled to the end of the cycle time.

If red-yellow or yellow phases exist for the respective group, green can only be drawn until there is only one second left in the intersection time plan.

A lock is then implemented at this point.

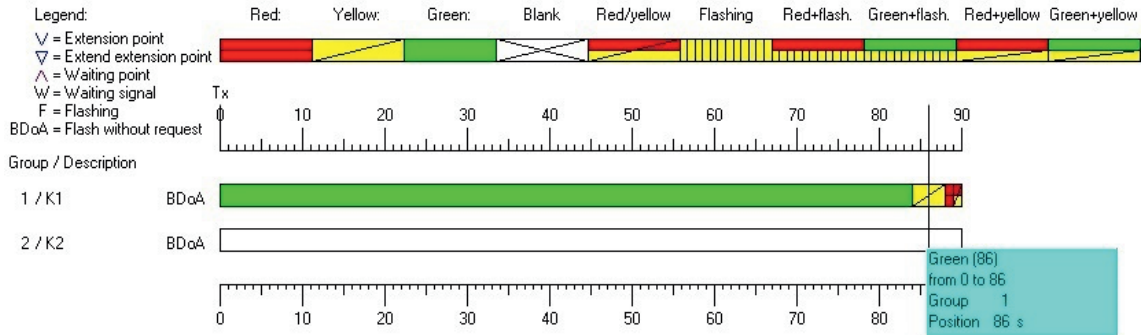

To draw continuous green now, the mouse cursor is pulled on across this lock to the end of the cycle.

The drawn green phase then becomes continuous green, and existing red-yellow and yellow phases are hidden.

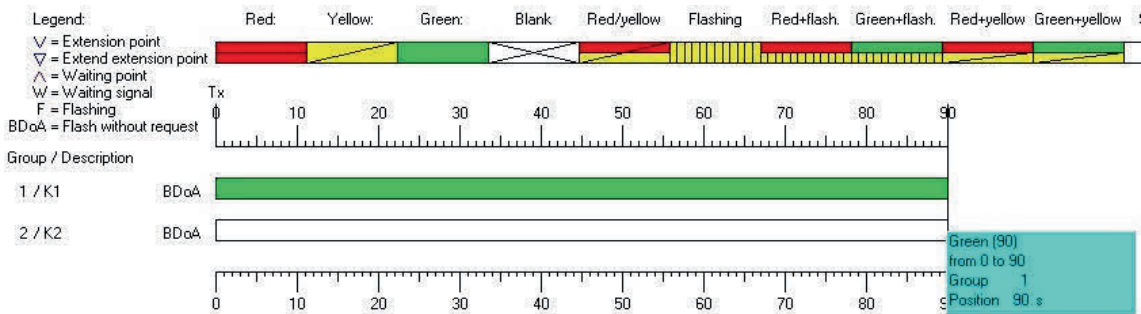

6.3.4.1.4 Define green flashing time

If green flashing has been activated for a signal group, this is shown by default as green flashing for the drawn green phase.

Clicking on  defines the time for green flashing, e.g. the last four seconds of the green phase. The button locks when selected. The green flashing time can only be defined for signal groups with activated **Green flashing** function (6.1.5) and for which a green phase has already been drawn (6.3.4.1.1).

If one of these conditions is not fulfilled, a corresponding message or disabled symbol appears. Click the mouse in the already existing green phase of the required signal group: the first mouse click (left button) marks the start time. On reaching the required end position, click again with the mouse (left button) to confirm.

The green flashing range can always only be drawn from left to right!

Note:

It is always only possible to define one green flashing range for reach existing green phase.

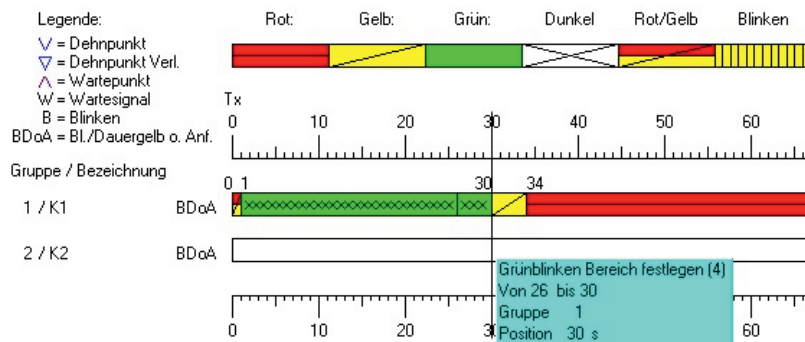

Information about the current group appears at the respective mouse position for greater clarity. The drawn time is then shown for the current group. The green phase graphic now changes. Only this part is shown as green flashing. The remaining green phase is shown as normal green.

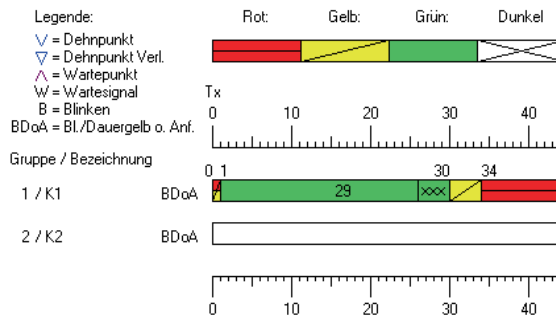

If the green flashing time is deleted, the entire green phase appears flashing for the groups with activated green flashing.

Note:

This function is only available from Ampeltools version 2.0

How to draw green flashing:

Basically, begin by drawing a green phase. This appears as continuous green flashing or normal green, depending on the setting. Within the green phase, now draw the part for green flashing. The remaining time is then normal green. If no green flashing time is drawn, green flashes for the whole green phase.

Note:

This function is only available for EPB 12 / EPB 24 / EPB 48 from version 7.00.

6.3.4.2 Draw blank

Click on  to activate the **Draw blank phase** function, which locks when selected (see **Draw green phase**).
The blank phase is shown with or without red-yellow / yellow phase, depending on the settings in the master data,

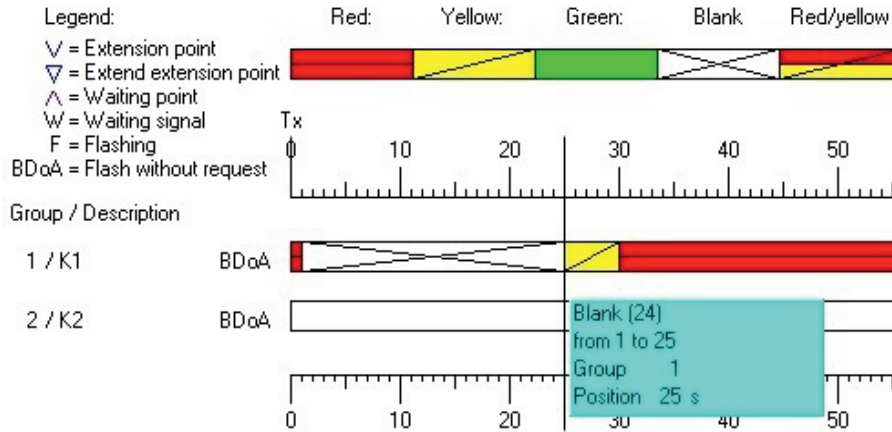

Note:

The drawn blank phase appears green, depending on the controller and version.

6.3.4.3 Draw combination of green and blank

Green and blank can be drawn together within a group. But this is limited to altogether two start-ups in the cycle.

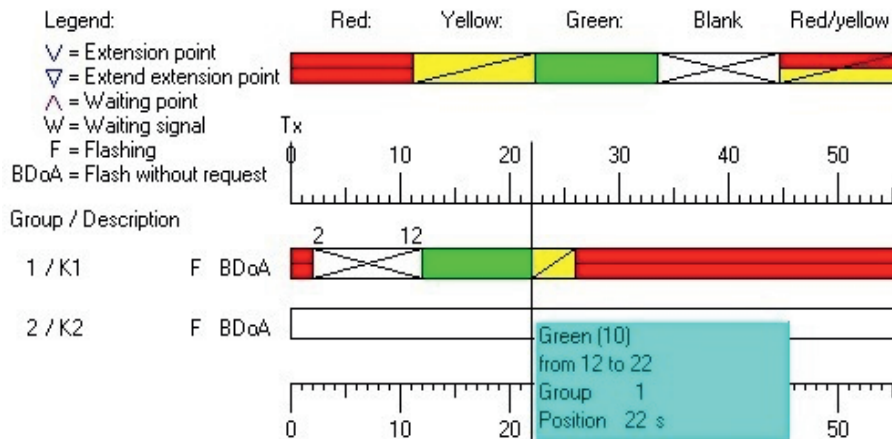

The blank phase is switched with a colour sequence, depending on the settings in the master data,

Please note the following when drawing:

For example, for a green phase to follow on directly after a blank phase, the red-yellow phase for this group must be 0 and there must not be any transition time for blank with yellow. This applies in both directions.

Note:

If a program with a combined blank and green phase is transmitted to the controller (only EPB 12 / EPB 24 / EPB 48), the controller switches to green instead.

6.3.4.4 Draw red

Click on  to activate the **Draw red phase** function (see **Draw green phase**). The button locks when selected, but in this case, group continuous red is drawn.

The system does not check for interim time errors when drawing a red phase.

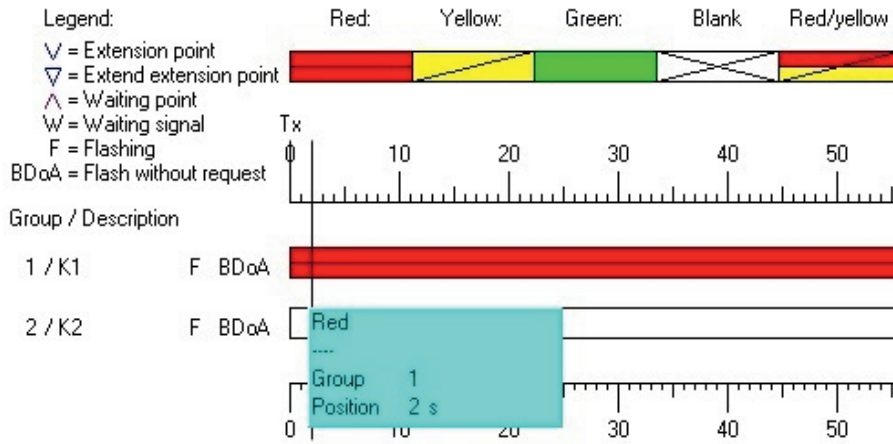

6.3.4.5 Draw continuous yellow

Click on  to activate the **Draw yellow** function (see **Draw green phase**).
The button locks when selected but the system does not check for interim time errors.

There are two ways of drawing a continuous yellow phase:

Version 1: as individual group using only the yellow output.

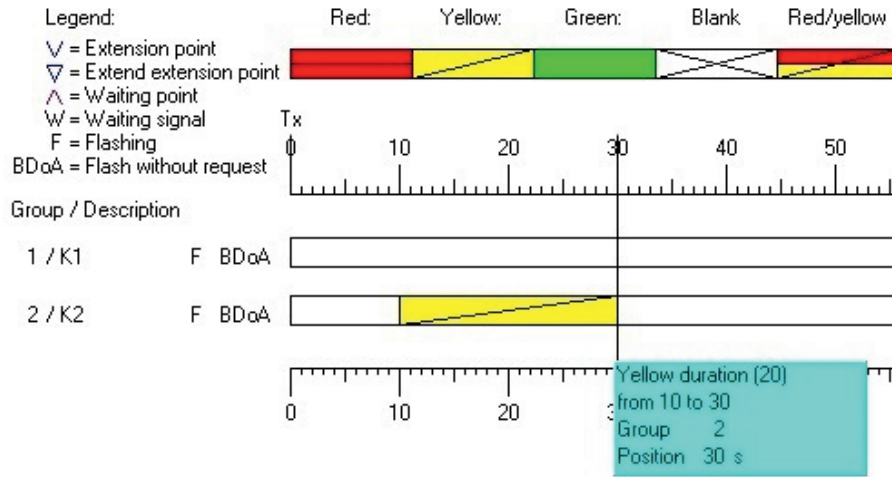

View: drawing of continuous yellow.

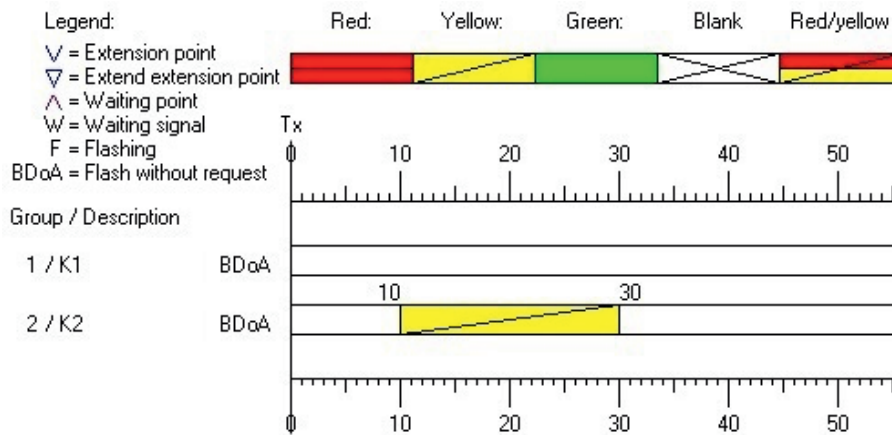

Version 2: within a group where the yellow output is already in use.

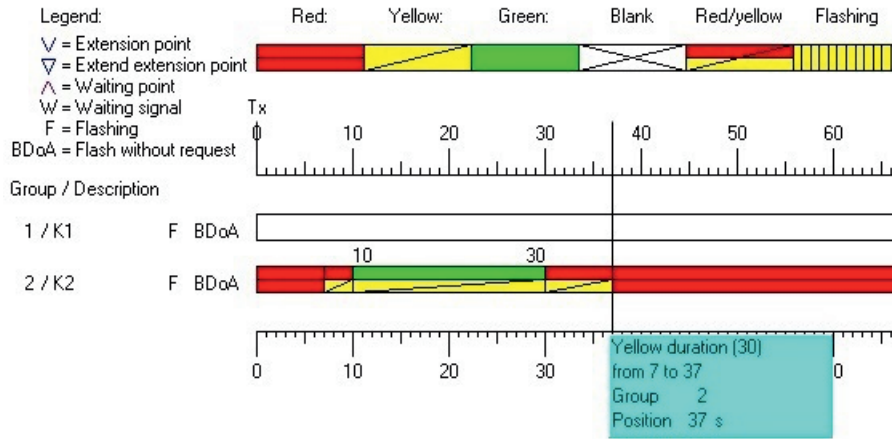

View: drawing of continuous yellow with green.

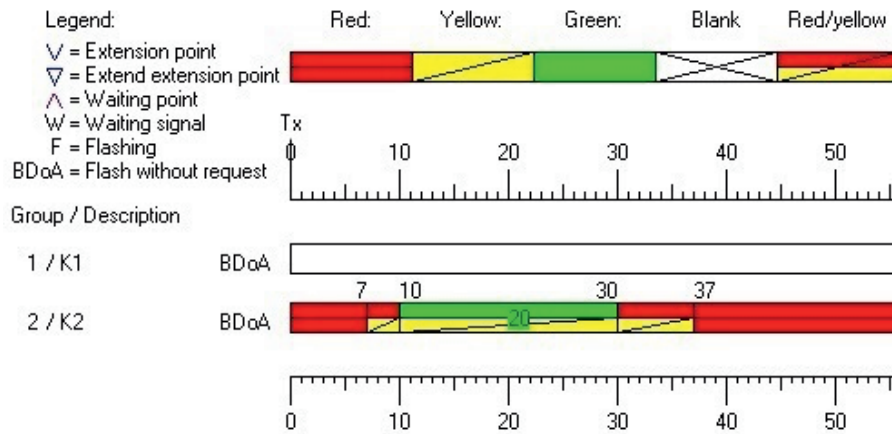

Note:

For controller MPB 4xxx, the continuous yellow function is switched via red 2 output at the parallel signal head output if there are no red-yellow or yellow phases.
If only one individual yellow phase is used without drawing a green phase, a red-yellow and a yellow-phase must be entered for the corresponding group.

6.3.4.5.1 Draw pilot signal

It is necessary to draw a pilot signal when using tactile signal heads (e.g. acoustic signals for the visually impaired, vibration button).

To do so, please use the continuous yellow button, □ **6.3.4.5**

For signal groups declared as tactile signal groups in the master data, another graphic is used instead of yellow. Yellow is used for all other signal group types.

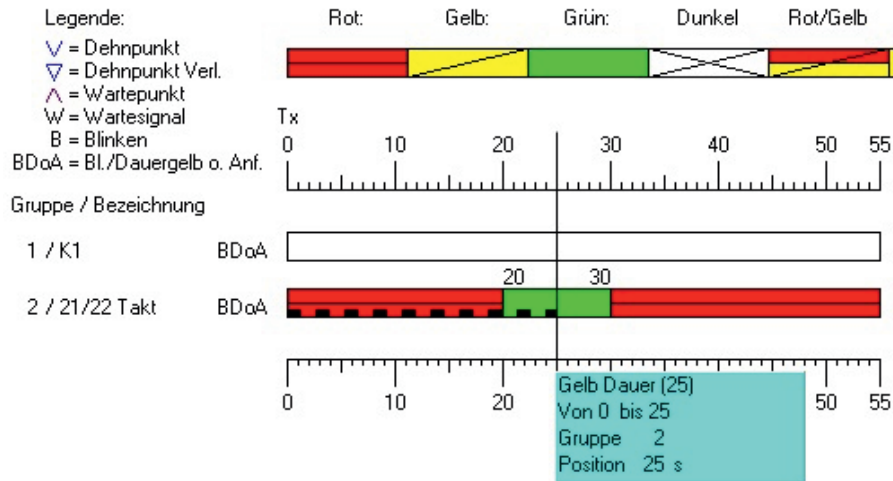

View: drawing of pilot signal.

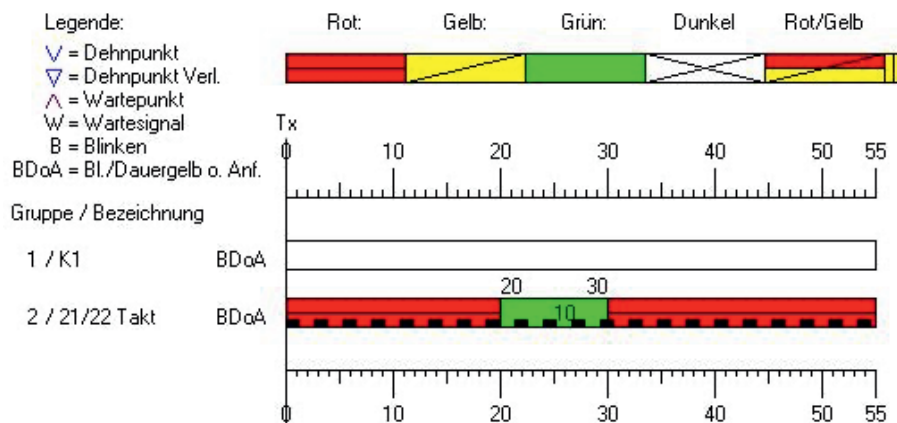

Note:

On the controller, the yellow output is always used for the pilot signal.

6.3.4.6 Draw flashing



Click on  to activate the **Draw flashing** function (see **Draw green phase**). The button locks when selected but the system does not check for interim time errors. There are two ways of drawing a yellow flashing phase:

Version 1: as individual group using only the yellow output.

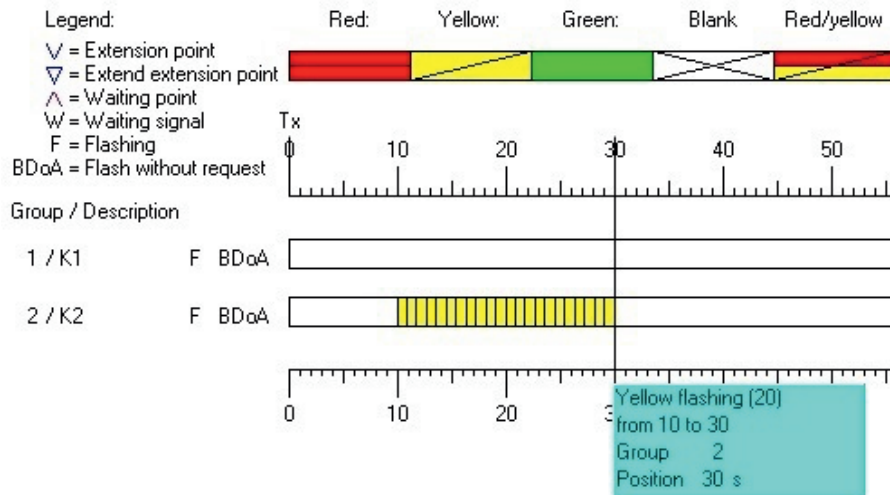

View: drawing of yellow flashing

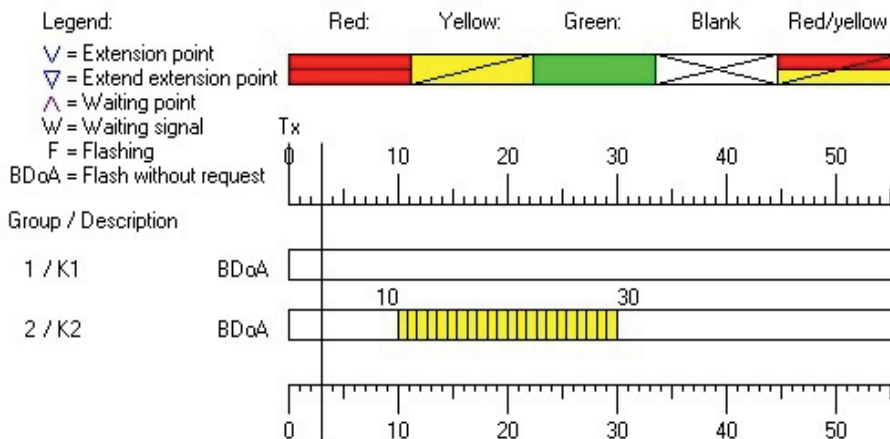

Version 2: within a group where the yellow output is already in use.

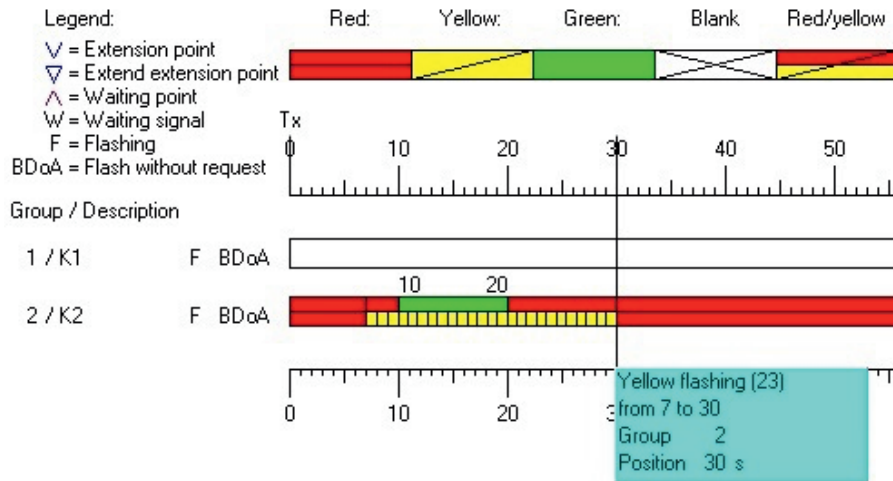

View: drawing of yellow flashing with green.

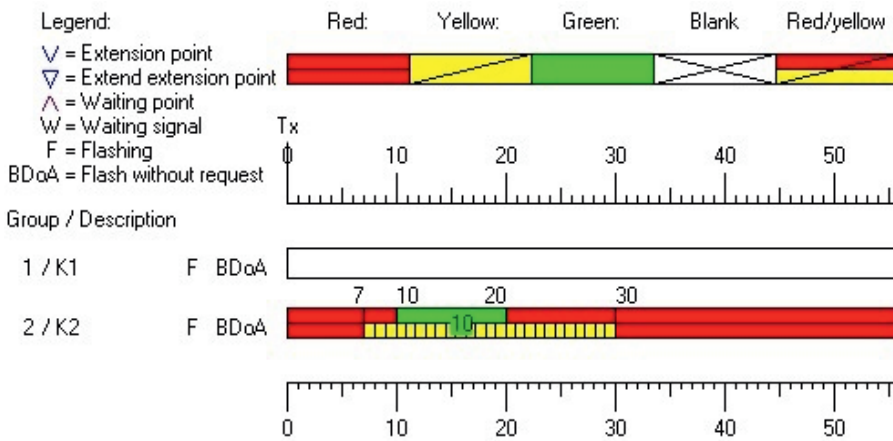

Note:

For controller MPB 4xxx, the yellow flashing function is switched via red 2 output at the parallel signal head output if there are no red-yellow or yellow phases.
If only one individual blinker is used without drawing a green phase, a red-yellow and a yellow-phase must be entered for the corresponding group,

6.3.4.7 Draw alternate blinker

Clicking on  activates the function to draw alternate blinkers; the button locks when selected.

Alternate blinkers can only be drawn for signal groups that have been declared as alternate blinkers in the signal group master data, see 6.1.3.

If this condition is not fulfilled, a corresponding message appears.

Click the mouse in the required signal group: the first mouse click (left button) marks the start time. On reaching the required end position, click again with the mouse (left button) to confirm.

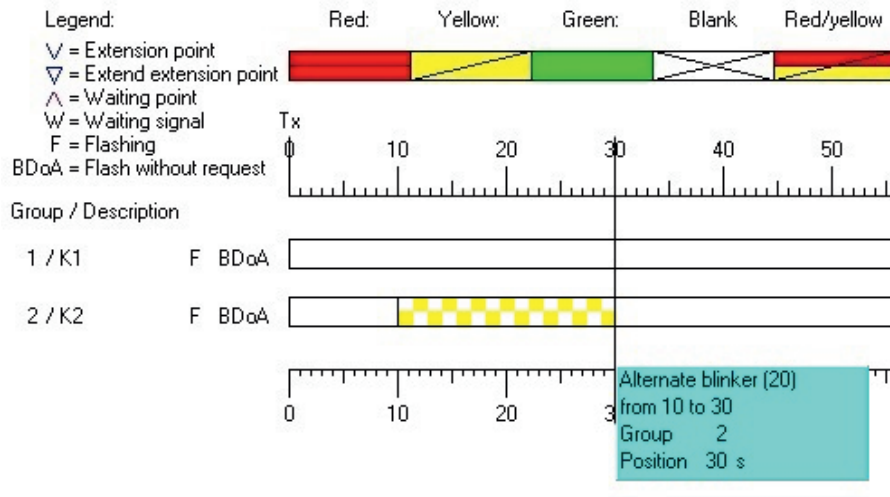

The drawn time is then shown for the current group.

Information about the current group appears at the current mouse position for greater clarity.

The output of an alternate blinker is then via the red and green output of the respective group. A standard 2-aspect pedestrian signal head can be used for this purpose, simply replacing the illuminants with the required symbols.

It is not possible to draw another colour for signal groups declared as alternate blinkers!

Note:

This function is supported from CPU version 7.00 (EPB 12 / EPB 24 / EPB 48).

6.3.4.8 ON time (EZP)

Click on **EZP** to set the ON time in an intersection time plan.
 Once positioned in the right place, the value appears in the EZP box below the editor.
 When a program is started at the controller, it jumps to the ON time at the end of the switch-on program. The actual program then begins.

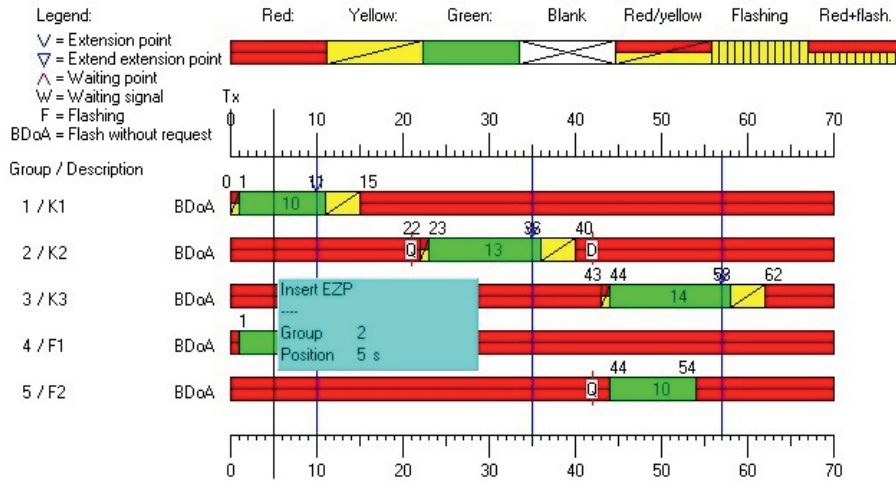

Note:

If no EZP is set, the program always begins at second 0 after the switch-on program.

6.3.4.9 OFF time (AZP)

Click on **AZP** to set the OFF time in an intersection time plan.
 Once positioned in the right place, the value appears in the AZP box below the editor.
 When a program is ended at the controller (flashing, blank), the program continues to the AZP and then carries out the corresponding switch-off program.

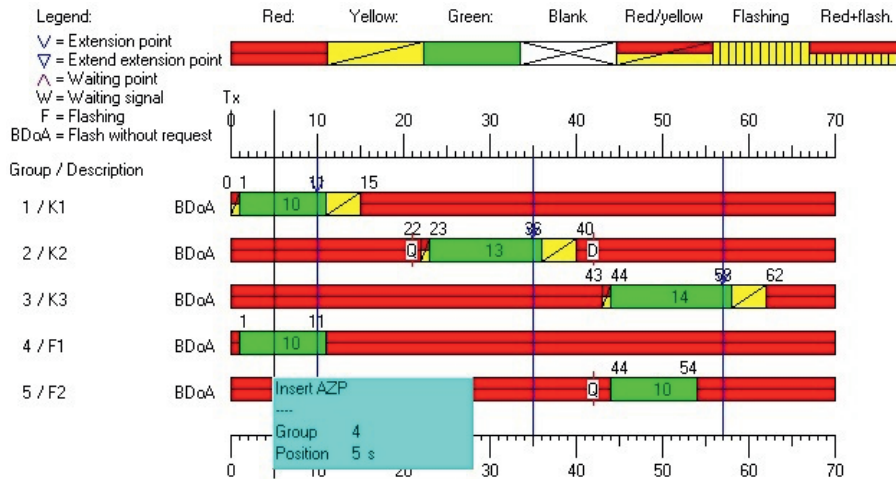

Note:

If no AZP is set, the current program always ends at second 0.
 The controller then switches off with the specific switch-off program (if entered).

6.3.4.10 Best/common switching point (GSP).

Clicking on **GSP** sets the GSP in an intersection time plan. This function is not enabled until several programs are available.

Once positioned in the right place, the value appears in the GSP box below the editor. Select the GSPs so that all groups show the same signal pattern at this point in time.

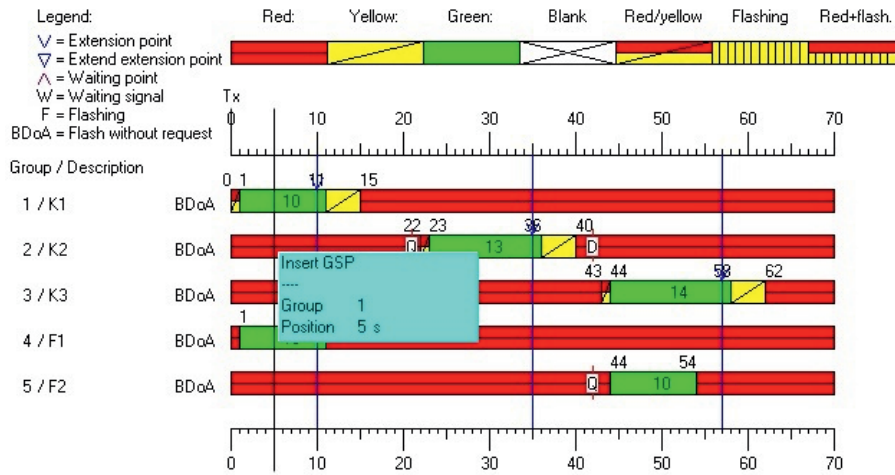

At the same time, the system checks whether the signal pattern is the same at the current position in the other signal programs. Programs where the signal pattern is not the same are highlighted in colour in the mouse cursor.

This check is only done in signal programs with values, but the required GSP can be positioned at any point.

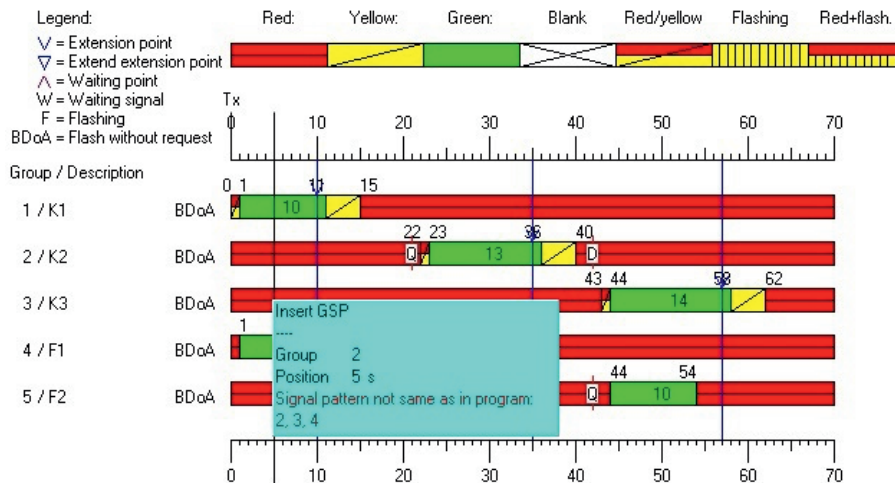

Notes:

- If no GSP is set, the program change always begins at second 0 (cycle second) of the current program.
- If a lock symbol appears at the point where the GSP is to set, that means that another GSP is already set at this point.

6.3.4.11 Additional GSP

Click on **GSP2 GSP3 GSP4 GSP5 GSP6** (only enabled if there are several programs) to set additional GSPs in the intersection time plan. The program change always takes place from GSP2 to GSP2, GSP3 to GSP3, etc.

Once positioned in the right place, the value appears in the GSP box below the editor. Positioning additional GSPs is the same as for the GSP. ↩ **6.3.4.9**

If an additional GSP is positioned at second 0, this is deleted and a message appears.

As a standard default, the GSPs are reserved for program change on request and are then used solely for this function.

The specific entries made in the program change on request mask define when which additional GSP is used. ↩ **6.4.2**

A selection box can be used to enable these GSP for the regular program change; the selection is made separately for every program.

When the program is about to be changed, the controller changes the program at the first additional GSP to be found.

Notes:

- If one of the additional GSPs is positioned in the second 0, this is disabled. For this to be carried out at second 0, it must be placed at the cycle second.
- Additional GSPs cannot be placed on already existing GSPs.
- As with the regular GSP, the system checks whether the signal pattern is the same in all programs.

6.3.4.12 Additional GSP only on request

The selection box **GSP2 - 6 only on request** is used to enable these GSPs for regular program change. The selection is made separately for each program.

When the program is about to be changed, the controller changes the program at the first additional GSP to be found.

Programs where the selection box has been disabled no longer use these GSPs for program change on request.

6.3.5 Edit intersection time plan

Various editing tools are available once an intersection time plan has been created.

6.3.5.1 Increase / end cycle time

Click on  to open a window for selecting the required function.

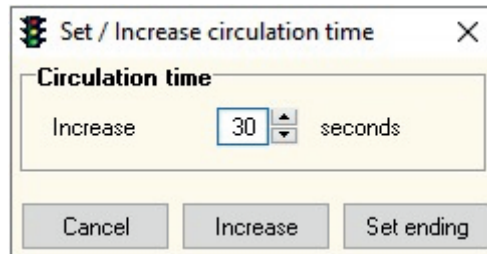

If the input window is closed with **Increase**, the cycle time is increased by the stated value, up to the maximum possible value.

When closing the window with **Set ending** the end of the cycle time can be ascertained according to the still necessary interim time. To do so, move the mouse cursor in the cycle towards the end of the cycle. The end of the cycle cannot be set in an area where there are still interim time errors. A lock symbol appears in this case. The end of the cycle can be set as soon as the lock symbol at the mouse cursor goes off.

Note:

The cycle time maximum 240 seconds. This is the minimum cycle time and can be increased with extension points.

6.3.5.2 Change red phase

Click on  to change the red phase. A window opens for selecting the required function:

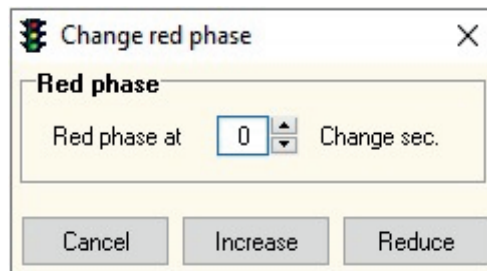

If the input window is closed with **Increase**, the red phase is increased by the selected value. Closing with **Reduce** reduces the red phase by the stated value. However, the system checks the interim times and the lock symbol appears if the red phase cannot be reduced at the selected point.

Note:

This function is not possible with the following signal statuses at the selected point (a lock symbol appears):

- green
- blank
- red-yellow
- yellow (not continuous yellow)

If the function is carried out and values are present for request query and target, the following message appears:

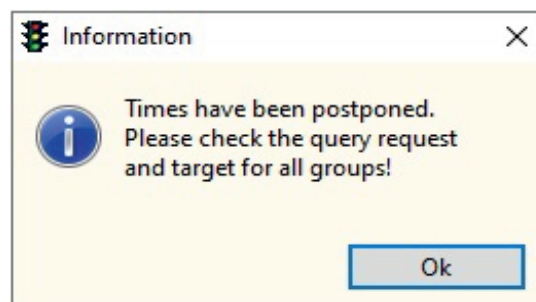

6.3.5.3 Move intersection time plan

Use  to move an intersection time plan by the stated value.

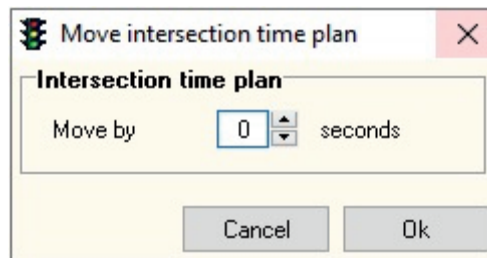

Close the window with **OK** to move the intersection time plan by the stated value.

Note:

The following parameters are not moved:

- Syn 1 + 2
- Syn out 1 + 2

6.3.5.4 Fill intersection time plan

Use  to fill a drawn intersection time plan. In doing so, the missing red phase is inserted for all drawn groups.

This function is only needed if **Fill automatically** is disabled in the program settings.

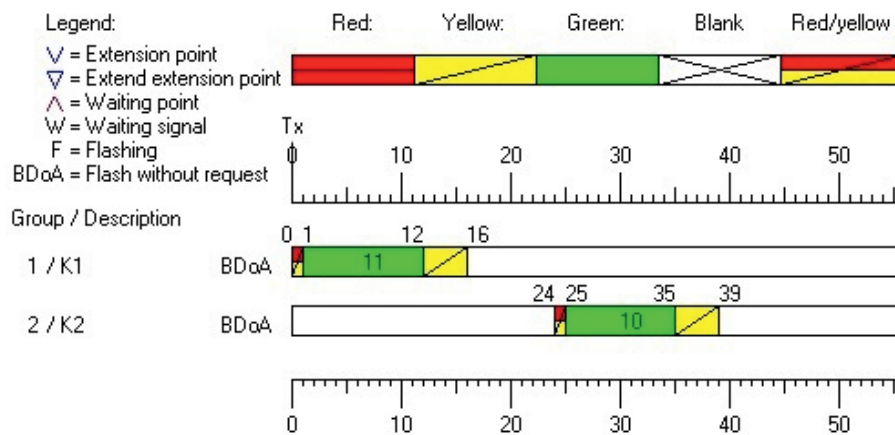

6.3.5.5 Adjust intersection time plan to min interim times

Use  to adjust the interim times between two groups automatically to the minimum value (according to the interim time matrix).

Function:

First, mark the signal group where you want to begin. Then mark the signal group to be adjusted to the first marked signal group. This is adjusted automatically to the first marked signal group, while heeding the interim time.

Depending on the interim time stated in the intersection time plan, the second signal group is moved closer to or away from the first signal group.

Please note:

- If the interim time from the source group to the target group is larger than in the interim time matrix, the target group is always moved to the left accordingly.
- If the interim time from the source group to the target group is smaller than in the interim time matrix, the target group is always moved to the right accordingly.
- If the interim time from the source group to the target group is larger than in the interim time matrix but the source group is not followed by a further group beginning with green, then the cycle time is adjusted.
- Adjustment is not possible if all groups are drawn the same, e.g. all begin in the first second with green.
- In signal groups with existing green flashing range, the green flashing range is automatically also shifted when optimising.

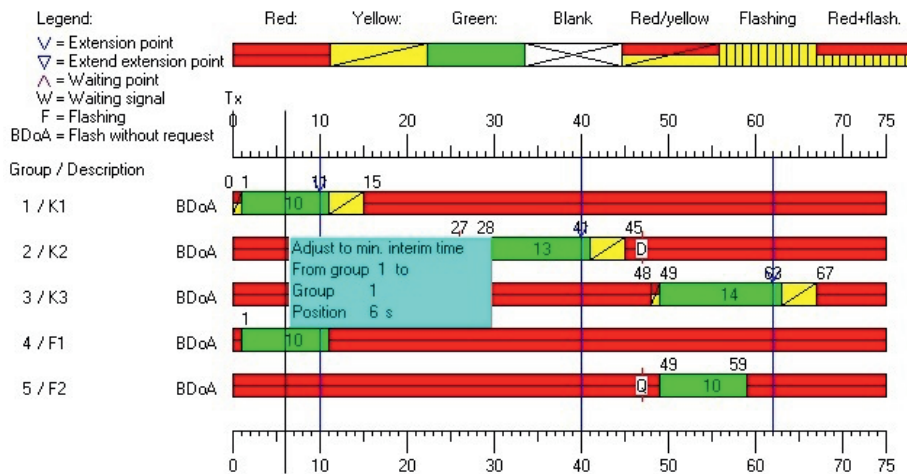

To optimise an intersection time plan with this function, work through all signal groups from left to right. Start with the first green phase seen from the left, then select the signal group for optimising.

Then move from this signal group to the next, etc.

The lock symbol appears if adjustment is not possible.

The easiest way is to draw all signal groups with the required minimum release time, as shown below:

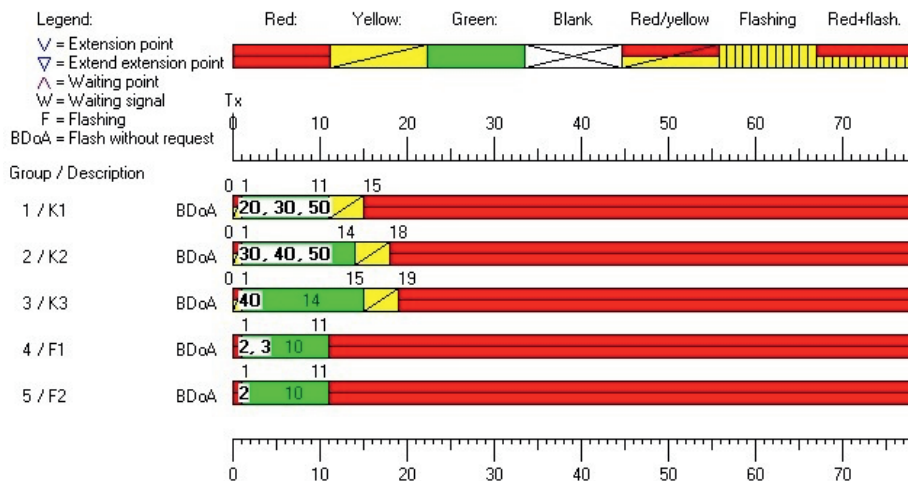

First draw the groups that should start first with green in the intersection time plan (groups 1 and 4 in the example). Then draw the minimum release time for all other groups as shown in the example. Please note that the green phase of the following signal groups begins later than that of the signal groups beginning first in the intersection time plan. Then continue optimising the signal groups in the required sequence as described above until you have created an intersection time plan without interim time errors.

The following message appears if it is not possible to make an adjustment between the selected signal groups:

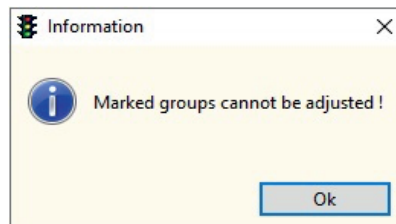

Note:

Adjustment is not possible if a double start-up has been drawn for the target group to be optimised (twice green in the cycle, twice blank or both combined). The following message appears:

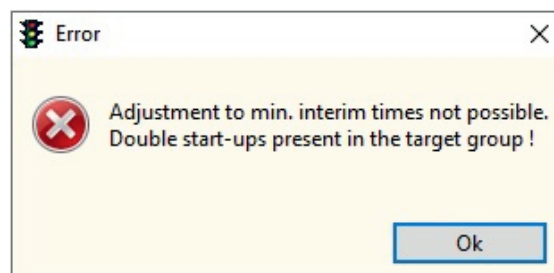

6.3.5.6 Adjust min. interim time to all signal groups



Use  to automatically adjust interim times to the minimum value (as per interim time matrix) from a selected signal group to all other signal groups in the intersection time plan.

Function:

First, mark the signal group where you want to begin. Then adjust all other signal groups to the already marked signal group, while heeding the interim time. All other groups are moved to the first marked signal group at the same time, which can result initially in interim time errors or overlap errors, which are then eliminated one by one.

Mark the next signal group that you want to start with. As a rule, this is the signal group next to the signal group marked first. Now move all signal groups to the right to the signal group marked active, while heeding the interim time. This results in interim time errors or overlap errors again. Repeat until there are no more interim time errors or overlap errors and you have created the best possible minimum intersection time plan. The lock symbol appears if adjustment is no longer possible.

Notes:

- Once signal groups have been marked, these are no longer adjusted for as long as the optimising function is active.
- Non-hostile signal groups are moved so that their green phase starts coincide.
- Signal groups whose green phase starts before or with the selected group are not adjusted.
- Renewed adjustment of all signal groups is possible after switching the optimising function off and on again.
- An intersection time plan created with this function can contain interim time errors that then have to be eliminated by inserting a red phase manually at the corresponding point.

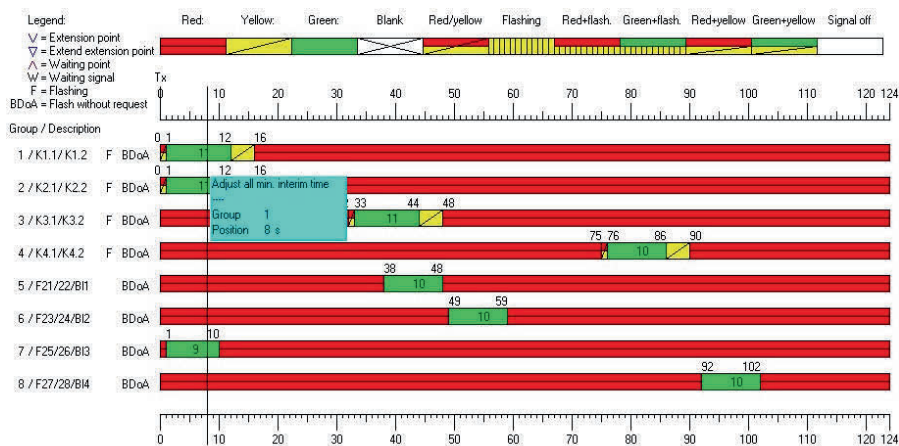

Note:

In signal groups with existing green flashing range, the green flashing range is automatically also shifted when optimising.

If all signal groups have been edited and no more adjustments are possible, the following message appears:

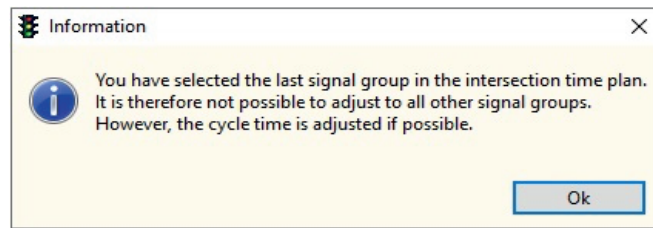

Confirm with **OK** to adjust the cycle time if possible.
The cycle time is then increased or reduced according to the remaining interim time.

6.3.5.7 Define best cycle (automatically)

Use  to automatically define the best cycle, while heeding the interim time.

Function:

Please select the signal group where you want to begin.
Start by clicking the left mouse button in the corresponding group.

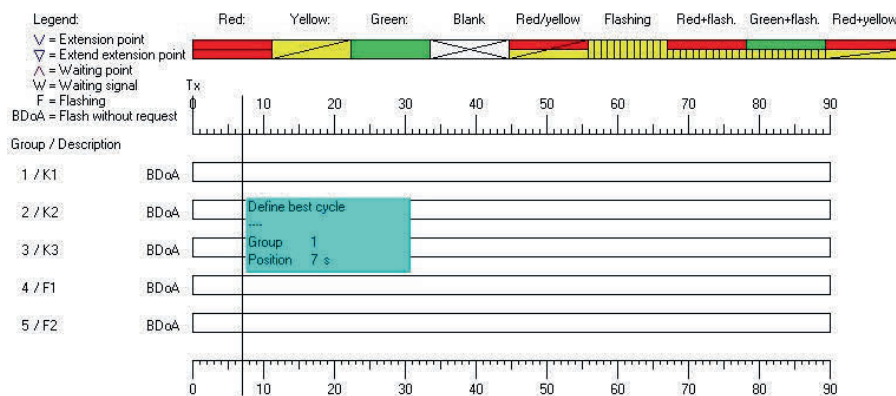

The program begins with the selected signal group and calculates the best cycle based on the interim time matrix. The minimum release time (value from the master data) is then drawn for all signal groups. The green start for the selected signal group is always in second one.

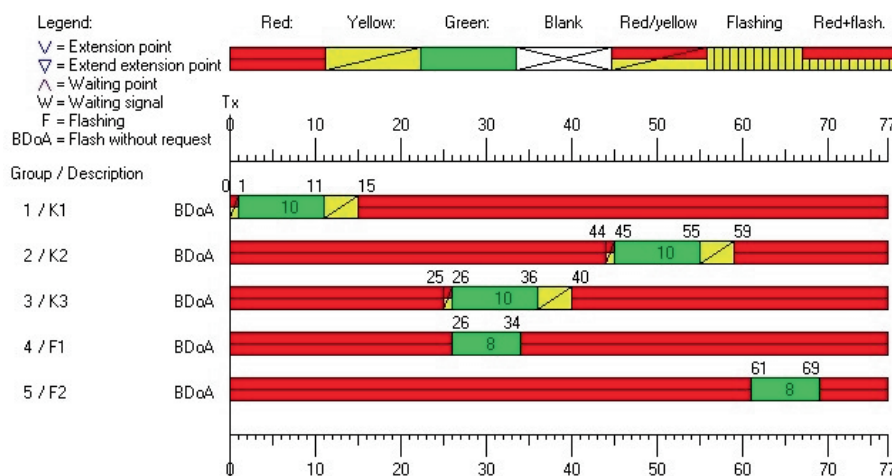

The best cycle is calculated with a stipulated algorithm. Click the left mouse button on the same signal group to use another algorithm.

If you start this function with every signal group as starting group with both algorithms, this results in different intersection time plans.

As user, you should select the intersection time plan that is best suited to the map.
The following algorithms are available:

Interim time-oriented:

On selecting a signal group for the first time, this acts as the basis for calculating which signal groups could come first using the interim time matrix. The pedestrian groups are drawn first together with the non-hostile vehicle groups so that these phases begin together. This is then repeated from the drawn groups and the next groups are drawn. Continue until all signal groups are in the intersection time plan (apart from auxiliary signals).

Group-oriented:

On selecting a signal group for the second time, the best cycle is defined in the sequence of the signal groups.

After starting with one signal group, from the next one the system defines how these can be inserted in the intersection time plan while heeding the interim time matrix. This is then drawn accordingly by Ampeltools.

Continue until all signal groups are in the intersection time plan (apart from auxiliary signals).

As soon as you click the left mouse button in another signal group, the process begins again with the standard algorithm. Defining the best intersection time plan then starts again from this signal group.

Notes:

- An existing intersection time plan is deleted on selecting a signal group to start the process.
- Defining the best cycle always begins with the selected signal group. With this as basis, the system defines the best sequence to the subsequent signal groups on the basis of the interim time matrix.
- To define an optimum intersection time plan, test this function with every signal group as the starting signal group.
- Signal groups declared to be auxiliary signals in the master data are not included in defining the best cycle. Nothing is drawn in the intersection time plan for these signal groups.
- In the case of a vehicle group that is not hostile to pedestrian groups, the green start is adjusted so that the green phase of both these groups begin together (if the pedestrian group has begun later with a green phase up to now).

RiLSA stipulation:

Pedestrian groups may not be switched subsequently to a non-hostile vehicle group. Their green phase must begin either before or together with the vehicle group and may not be switched subsequently to a vehicle group that already has green.

This adjustment means that in the intersection time plan, there may be higher interim times between signal groups than necessary in the interim time matrix. Depending on the adjustment, this may result in a longer cycle time than necessary.

Note:

The intersection time plan created with this function is just a suggestion. This intersection time plan does not necessarily result in the best intersection time plan that goes with the corresponding map.

6.3.5.8 Define best cycle (semi-automatically)

Use  to semi-automatically define the best cycle, while heeding the interim times.

Function:

Please select the signal group where you want to begin.

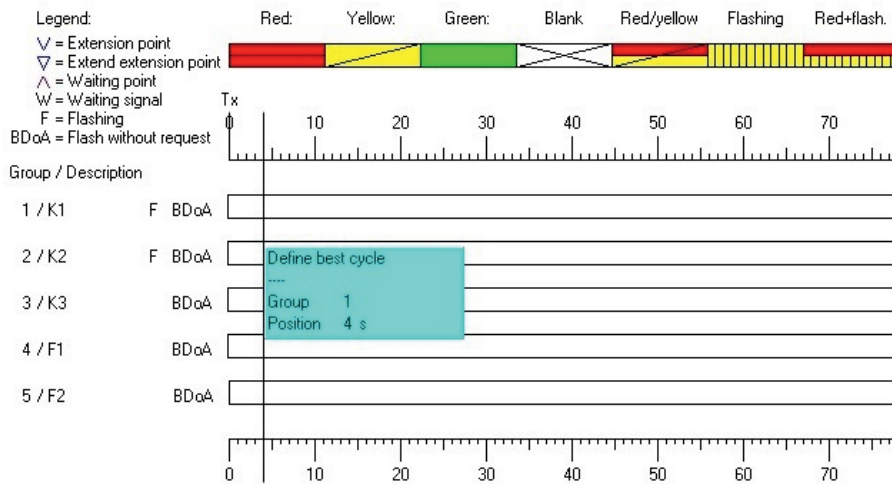

As soon as you click the left mouse button in the corresponding signal group, it is drawn in the intersection time plan with the minimum release time (from the master data) and the current cycle time is defined.

The green phase always begins in second one.

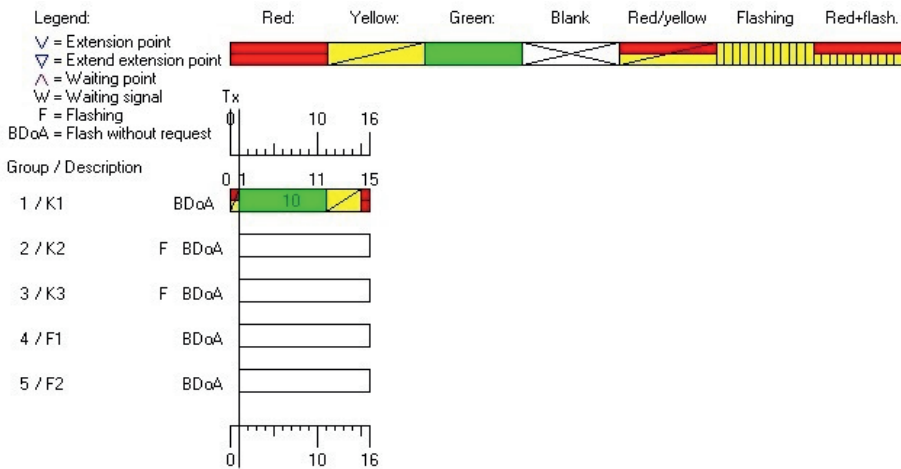

Then select the signal group to be inserted next in the intersection time plan. To do so, click the left mouse button in the required signal group in the intersection time plan. This signal group is then drawn in the intersection time matrix with the minimum release time (value from the master data) and the cycle time is adjusted accordingly.

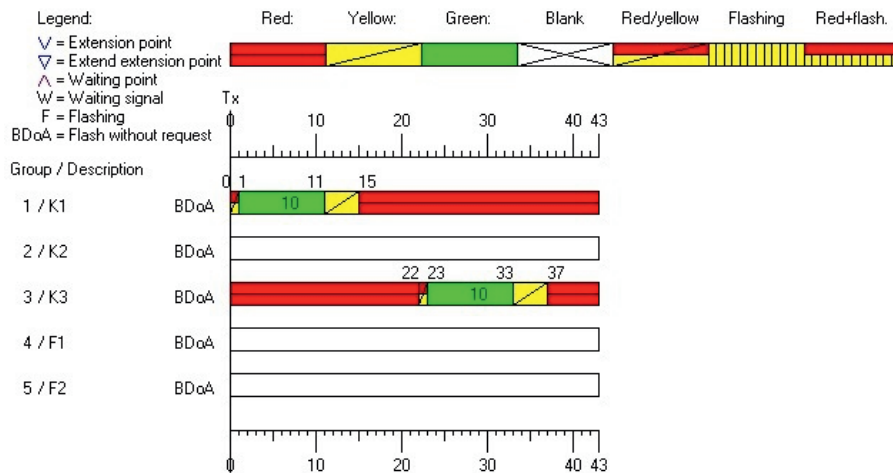

Repeat until all signal groups are in the intersection time plan. If you select a signal group where a green phase has already been drawn, the following message appears:

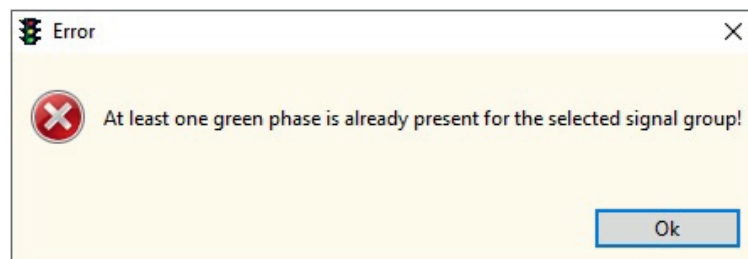

Notes:

- Any existing complete intersection time plan is deleted as soon as you select a signal group to start the process.
- If this function is switched off and on again in the meantime, the semi-automatic function can still be used if no manual adjustments were made to the intersection time plan.
- If manual adjustments were made to the intersection time plan, the current intersection time plan is deleted as soon as you click the left mouse button in a signal group. The corresponding signal group is then drawn anew and the semi-automatic function can be used again.
- In the case of a vehicle group that is not hostile to pedestrian groups, the green start is adjusted so that the green phase of both these groups begin together (if the pedestrian group has begun later with a green phase up to now).

RiLSA stipulation:

Pedestrian groups may not be switched subsequently to a non-hostile vehicle group. Their green phase must begin either before or together with the vehicle group and may not be switched subsequently to a vehicle group that already has green.

This adjustment means that in the intersection time plan, there may be higher interim times between signal groups than necessary in the interim time matrix. Depending on the adjustment, this may result in a longer cycle time than necessary.

This version for creating an intersection time plan can be used to complete an intersection time plan that has been started manually.

However, this is only possible if the program has no interim time errors or manual additions such as extension point, sync. point GPS, etc. The following message appears if the function cannot be continued:

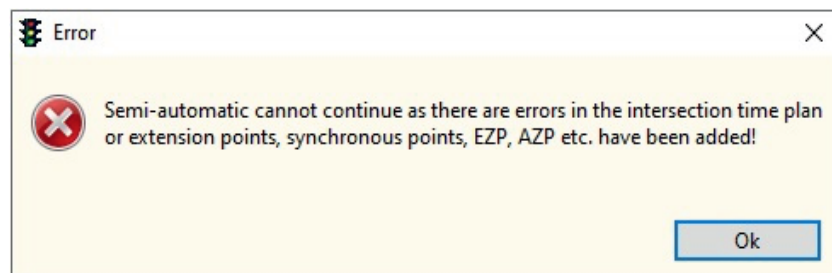
**Note:**

The intersection time plan created with this function is just a suggestion. This intersection time plan does not necessarily result in the best intersection time plan that goes with the map.

6.3.5.9 Move group



Use  to move the marked group to the target group, thus overwriting existing values. But only the green phases are adopted. The red-yellow and yellow phases are inserted from the master data of the target group.

When a group is moved, the system checks for interim time errors also at this point.

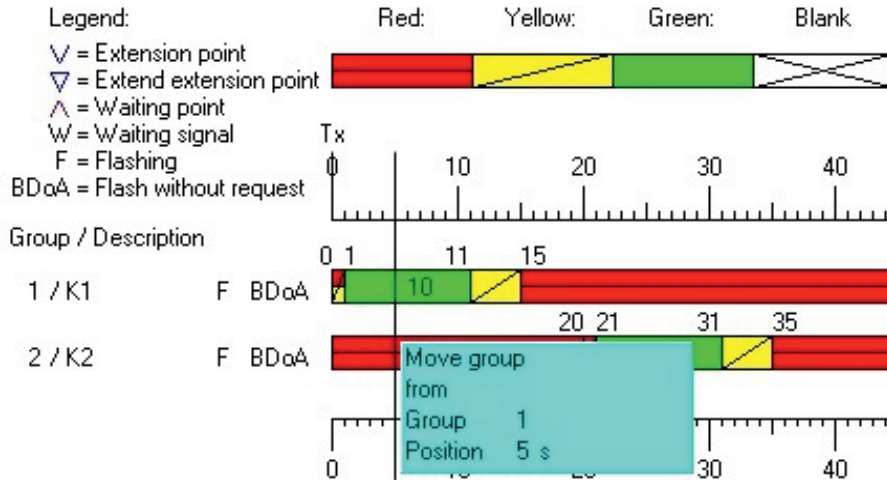

If a group has already been drawn at the selected position, before making the insertion the system queries whether this should be overwritten.

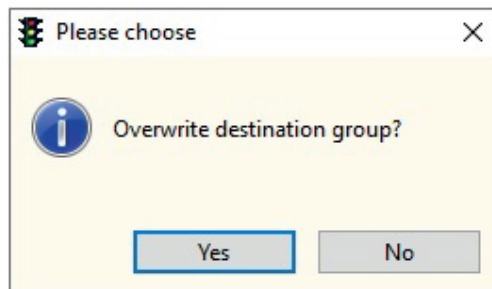

If the red-yellow or yellow phases in the target group are different to the group being moved, the following query appears:

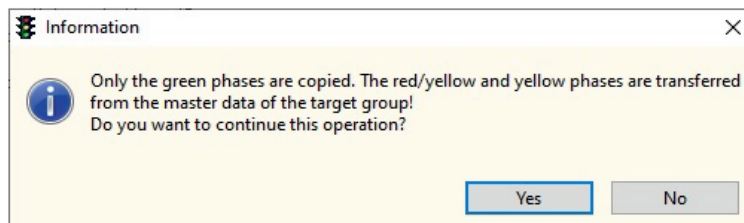

Yes moves the selected group, inserting it at the target position. The red-yellow and yellow phases are inserted from the master data of the target group.

6.3.5.10 Copy group

Use  to copy only the green phases of the marked group: they can then be inserted in other groups.

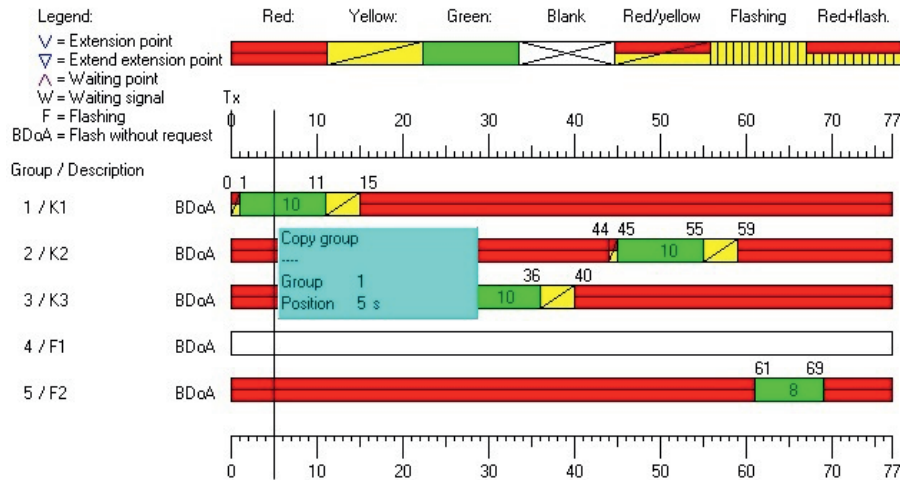

6.3.5.11 Insert group

Use  to insert the copied green phases of a group in the group marked as target. The corresponding red-yellow and yellow phases of this group are inserted from the master data. When a group is inserted, the system checks for interim time errors also at this point.

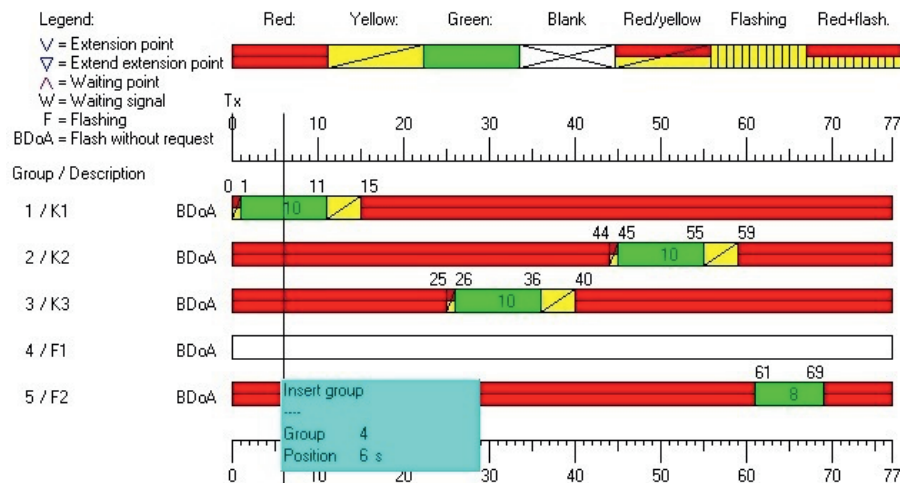

If a group has already been drawn at the selected position, before making the insertion the system queries whether it should be overwritten.

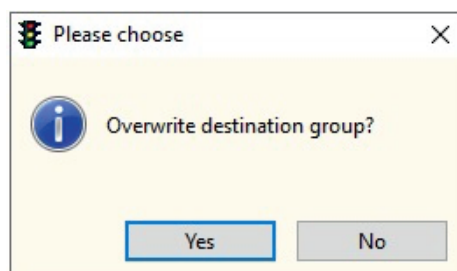

Depending on the confirmation, the target group is overwritten with the copied data.

6.3.5.12 Delete group

Use  to delete the group that is clicked after selecting the delete function. There is no confirmation query.

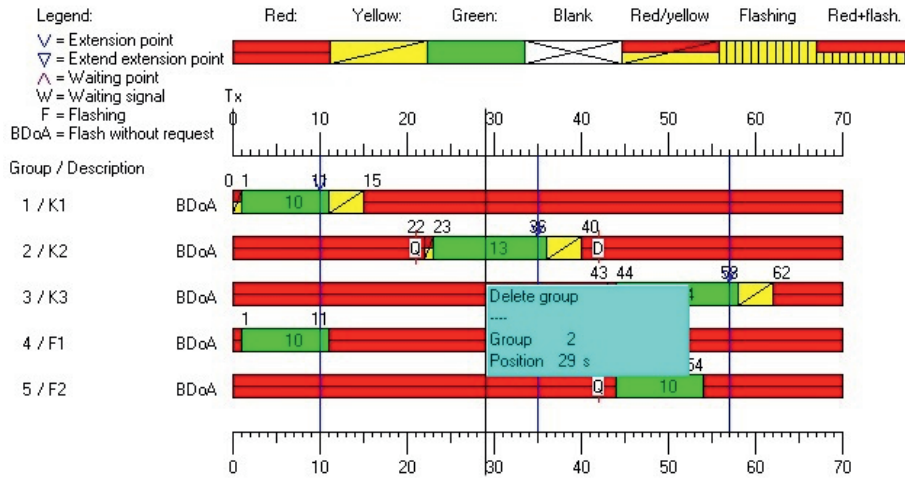

6.3.5.13 Move time



Use  to move the times within a marked group. The current values appear in the window. When a time is moved, the system checks for interim time errors also at this point.

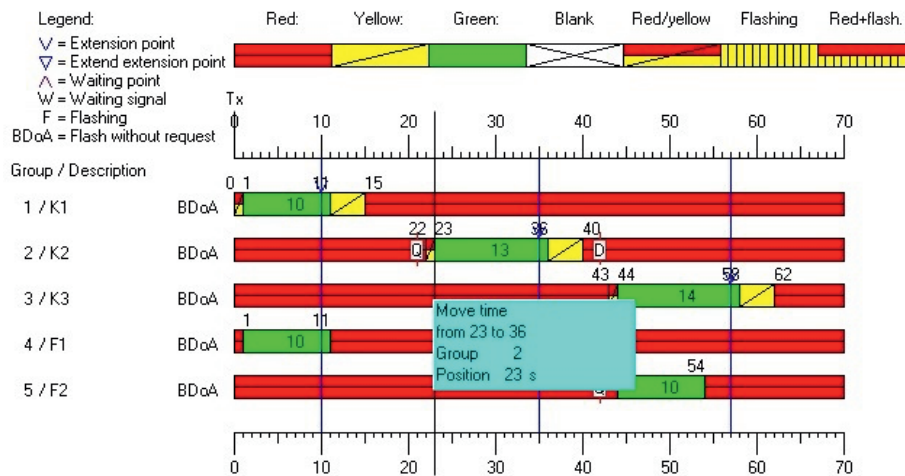

If the function is carried out and values are moved for request query and target, the following message appears:

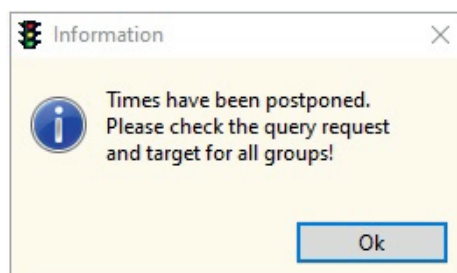

Note:

If a green phase with existing green flashing range is shifted, the green flashing range is automatically also shifted

6.3.5.14 Change time



Use to change the times in a marked group. The current values appear in the window. This function can always only be carried out at the start or end of a time. The time can be either increased or decreased.

When a time is changed, the system checks for interim time errors also at this point. All times can be changed apart from the red phase which is defined automatically. To change the red phase, please use the **Change red phase** function.

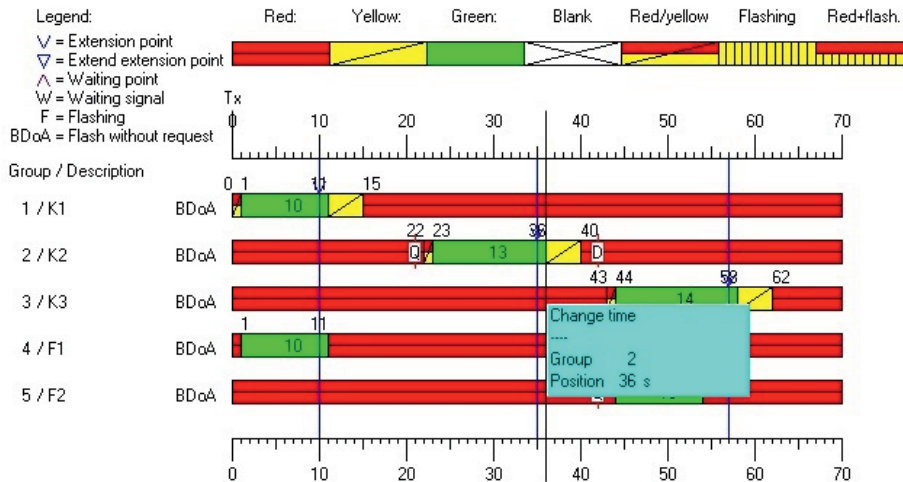

If a green phase has been changed and extension or waiting points are present, the following window appears:

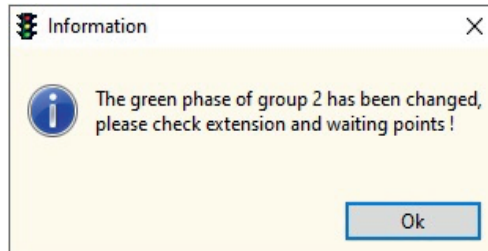

The following query appears after confirming with OK:

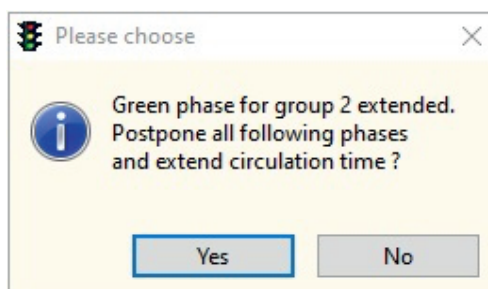

If the function is carried out and other values were changed for request query and target, the following message appears:

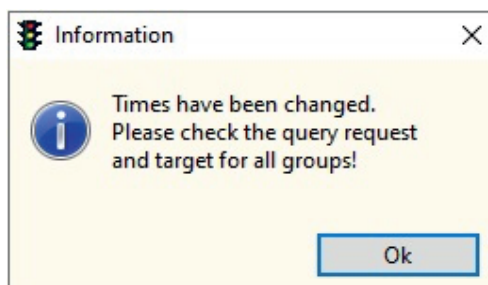

6.3.5.15 Change phase with green flashing range

The function is the same as described under **Change phase** (6.3.5.14). However, the green flashing range is automatically also shifted, depending on the direction in which the green phase is changed.

The green phases can only be changed so that at least one second of green remains plus the green flashing range, respectively the minimum release time is not undercut.

6.3.5.16 Delete time



Use  to delete individual times within a group.

If there are several times in a group, e.g. green and yellow flashing or a second green phase for one group, then only the marked time is deleted.

If there is only one time, this is deleted. There is no confirmation query.

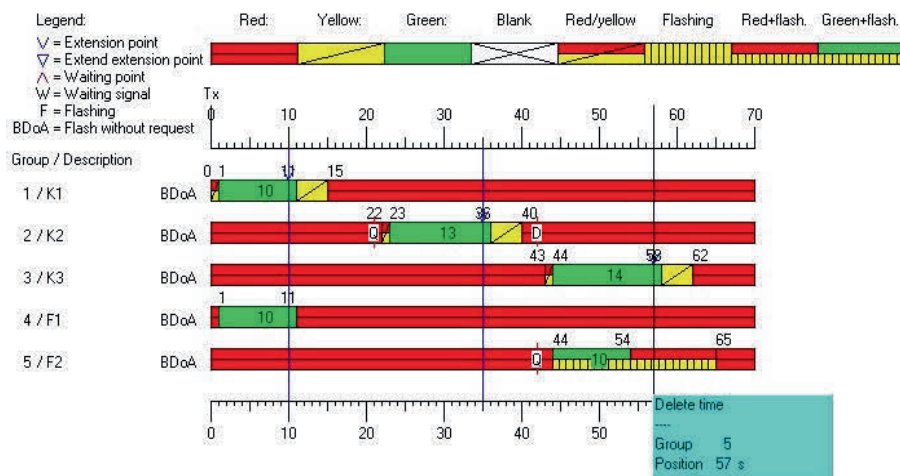

Note:

No extension and manual lock-in points are deleted if a yellow flashing, continuous yellow phase or the green flashing range is deleted.

6.3.6 Vehicle actuation

6.3.6.1 Extension points for green phase extension

Use **DP** to set extension points in groups. They extend the signal pattern in this second. Maximum two extension points can be positioned per group.

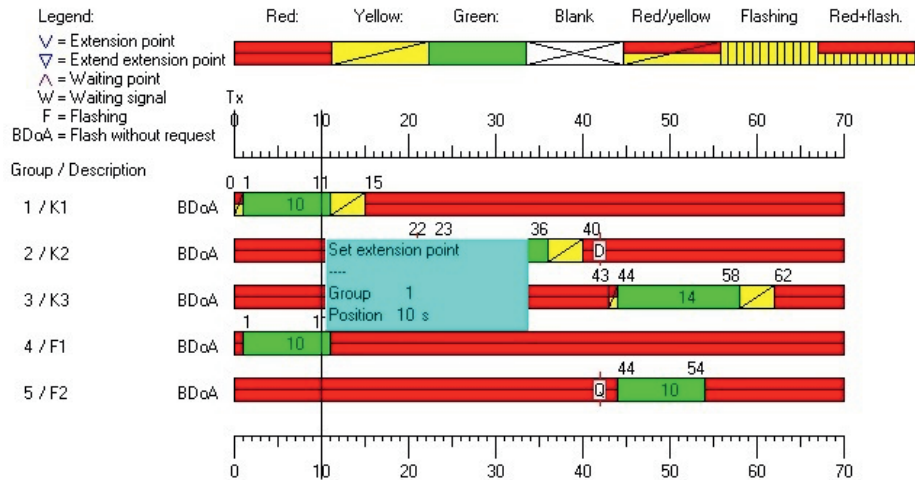

Once the extension point has been positioned at the required point, a window opens for further entries:

Extension group 2

Extension time: 40

Time gap: 5

Cancel OK

The value selected for extension time stipulates the length of time by which the corresponding group is extended.

The sum of extension time and drawn time results in the maximum green phase for the respective group.

The value for time gap indicates how much time there may be between detecting vehicles (e.g. radar detector, contact loop) until no more traffic is detected. There is no extension if 0 is entered for the time gap.

The controller then continues either when the extension time is reached or when the time gap is exceeded.

When the extension point is placed in the required position, a blue marking appears above this group. Double click on the marking to open this window for changing the values at any time. If extension points are set in the intersection time plan, take the mouse cursor over an extension point to see more information (extension time, time gap, green min and green max).

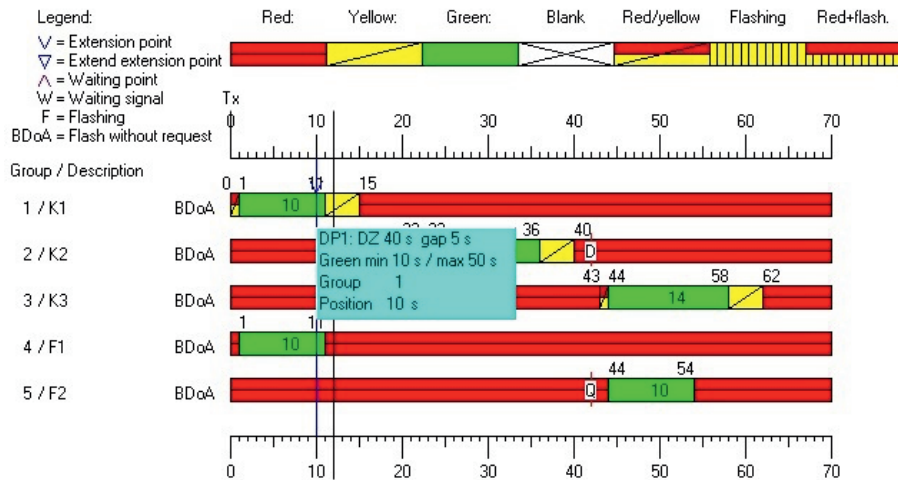

Note:

The maximum extension time is 240 seconds; the time gap is generally maximum 240 seconds.

As soon as extension points exist in the intersection time plan or are changed, the heading of the intersection time plan editor is updated. It always shows the minimum and maximum cycle time.

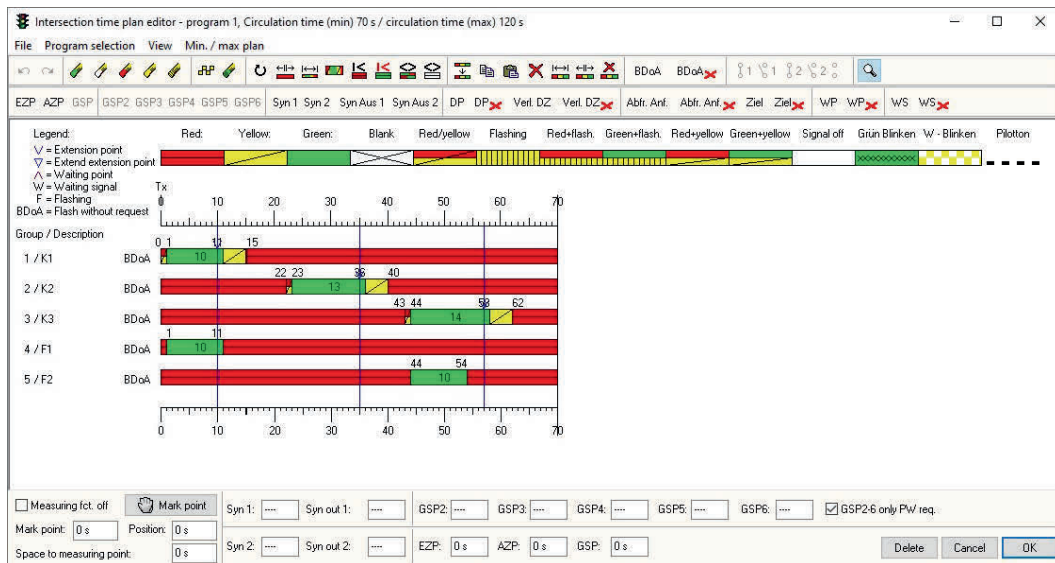

Use  to delete individual extension points again by simply clicking the mouse button on the corresponding extension point.

Note:

No extension point can be positioned at second 0. If an extension point is required at second 0, this must be positioned in the second of the cycle.

6.3.6.2 Waiting points for manual mode

Use **WP** to set waiting points in the intersection time plan.

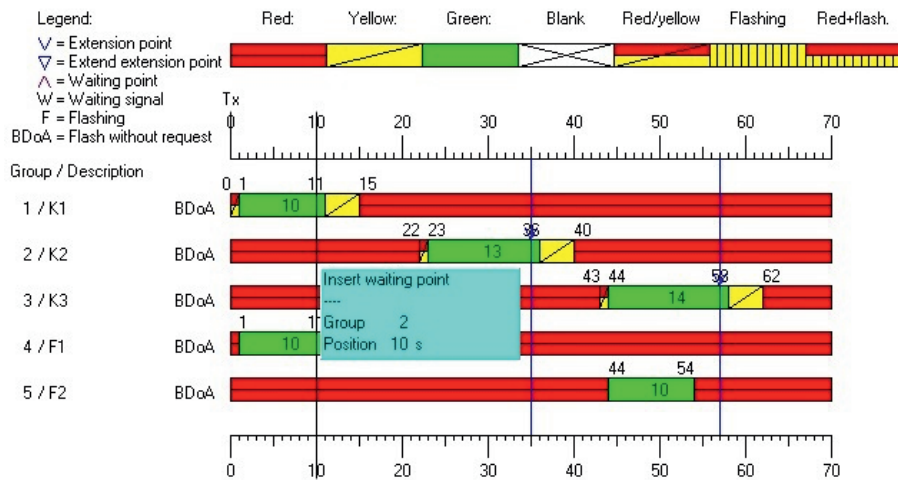

When the waiting point is placed in the required position, a purple marking appears below this group.

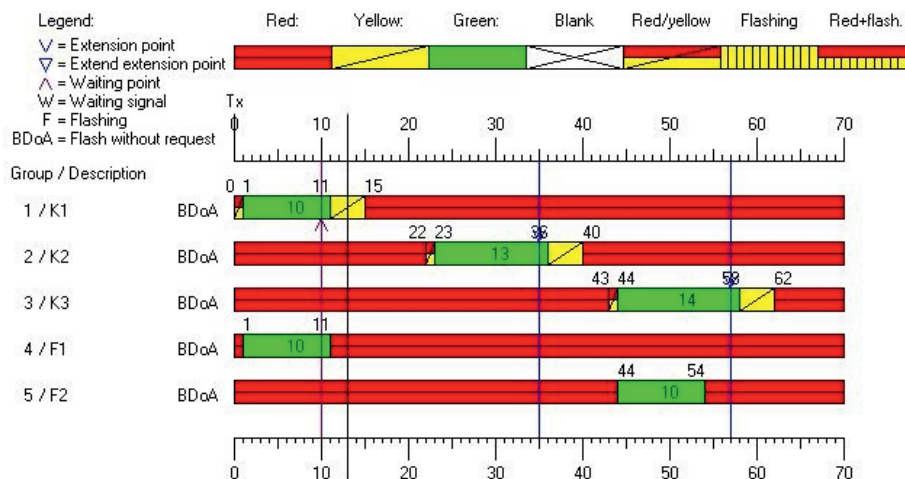

Notes:

- Maximum one waiting point can be positioned per group.
- No waiting point can be positioned at second 0. If a waiting point is required at second 0, this must be positioned in the second of the cycle.

Use **WP**  to delete individual waiting points again by simply clicking the mouse button on the corresponding waiting point.

6.3.6.3 Group on request

Use **Abfr. Anf.** to set query points for requests within the intersection time plan.

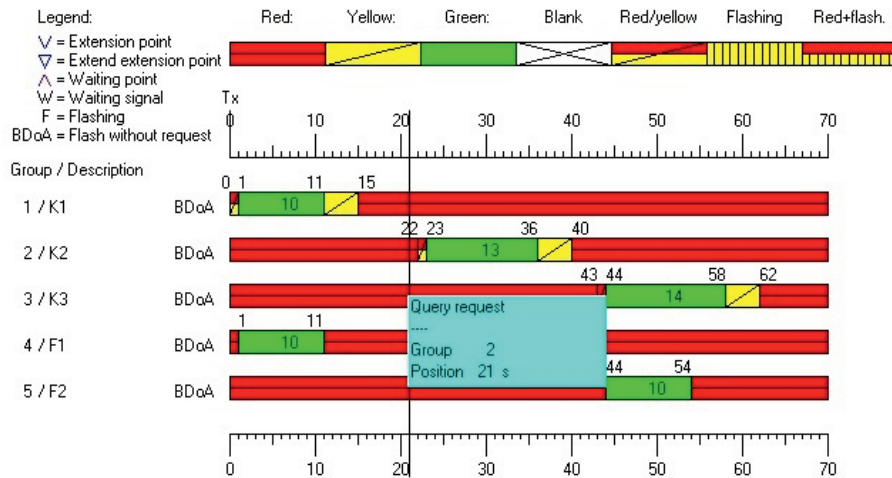

If you try to set a target point in a group where the request mode is not enabled, the following message appears:

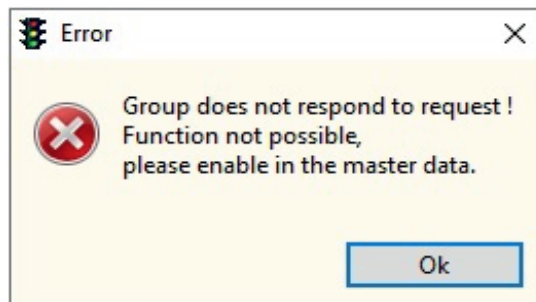

The group request mode then has to be switched on for this group in the master data. Once the query point is placed in the required position, this is indicated by **Q** appearing in the corresponding group.

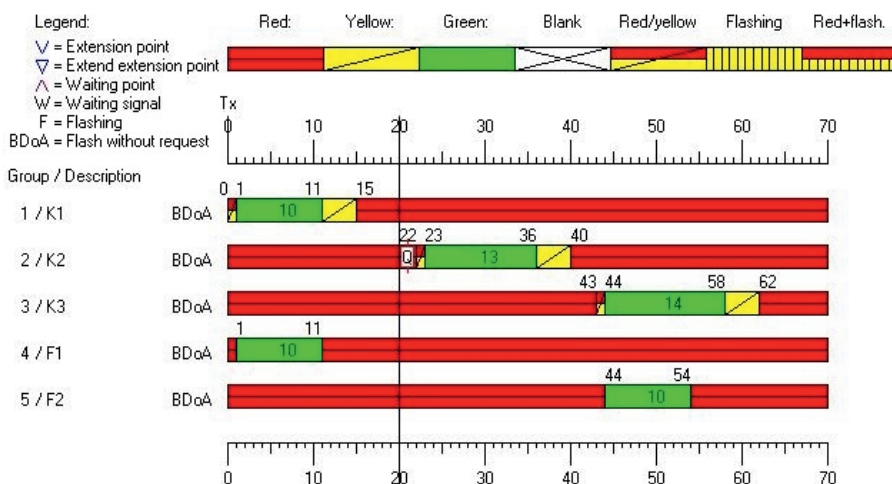

If the query point for a request has been set for a group, the green phase is only switched on request. At the position where this point is set, the program checks whether a request is present for this group. If so, it switches to green for the defined time. If there is no request, the group stays at red. For groups with a set query point for a request, an existing request is deleted when green starts.

For groups with no set query point for a request, an internal request is set automatically after green ends. These groups then switch to the fixed cycle.

Notes:

- A request should always be queried one second before green starts or before red-yellow, as requests after this point are only detected for this group with the next request query (one cycle later).
- The time of the request query should not be more than five seconds before the green start of the corresponding group, as otherwise the function **Prevent jump** cannot be carried out.
- No query points can be set in the red-yellow or yellow phase of a group. A lock symbol appears at the mouse cursor. Queries in continuous yellow or yellow flashing are possible.
- Maximum two query points can be set per group (not for MPB 4xxx).
- A query point for a request cannot be set at second 0. If a query point for a request is required at second 0, this must be positioned in the second of the cycle.

Use **Abfr. Anf.**  to delete individual query points again. To do so, simply click the mouse button on the specific query point.

6.3.6.4 Jump over group

As soon as a group switches to request (query for a request), it is possible to define the further behaviour of the corresponding group.

To shorten the cycle, so-called target groups can be used to jump over parts of the intersection time plan while heeding the interim times.

If no target point is set, the controller proceeds with the function Leave group out. The program does not switch the affected group to green if no request is present. The program then continues second by second.

Use Z_{iel} to set the target points.

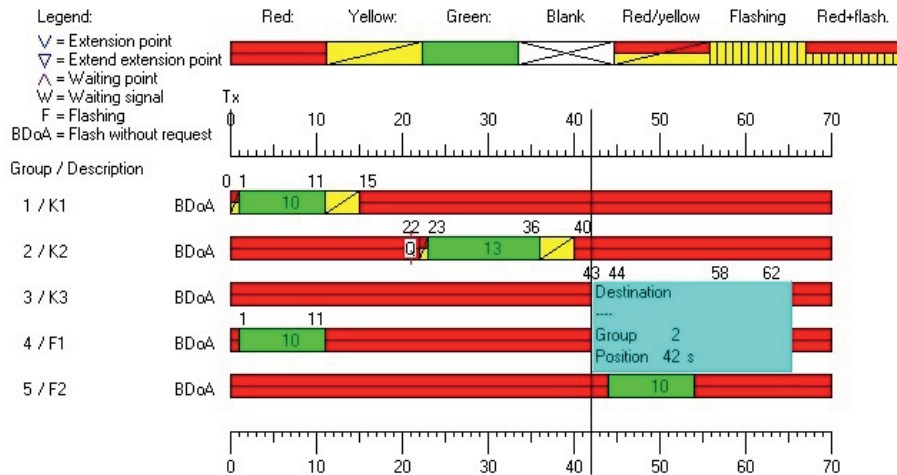

If you try to set a target point in a group where the request mode is not enabled, the following message appears:

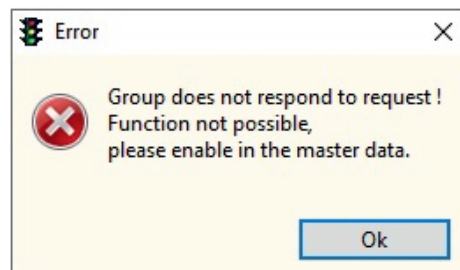

To use this function, the request mode must be enabled for the corresponding group in the master data.

Once the target point is placed in the required position, this is indicated by **D** appearing in the corresponding group.

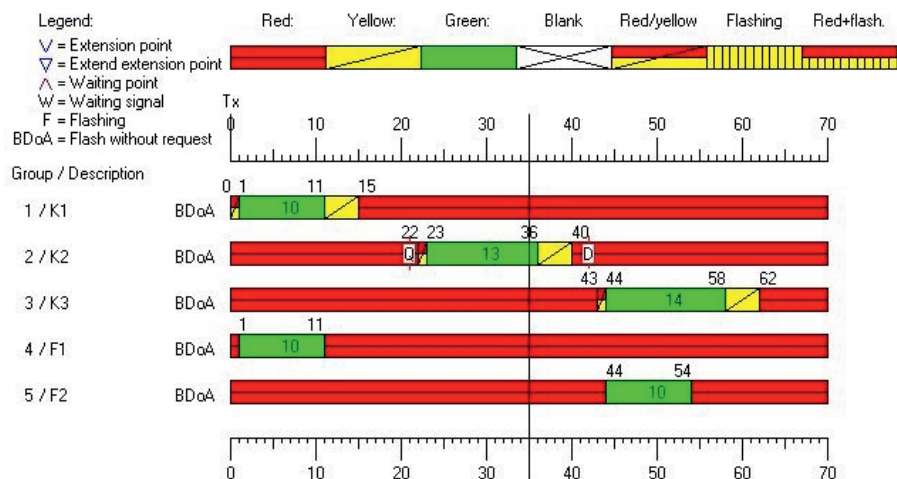

If a target point has been placed and there is no request for this group, a jump is implemented while heeding the ongoing interim times.

A jump is always implemented from the second of the request query to the set target of the affected group.

A jump is permissible directly from one request query to the next request query. This point in time is entered as target for the group doing the jump.

If there are no requests, in this case the cycle counter only shows the corresponding seconds.

Jump information:

If there is a request for a group and the program has reached the query second, a jump is prevented for five seconds (so that this group is not jumped over by subsequent queries - without requests).

Comply with the following jump conditions:

General:

- If a jump is carried out and the interim times have not yet expired, these are automatically moved. The controller waits the corresponding time until the jump.
- The jump target must be selected so that the target second is at least one second before the next signal changeover.
- On entering a jump target, make sure that the jump does not jump over other queries.
- For such a jump target (if there are requests for other groups), no jump is carried out. Instead the respective group remains at red (left out) so that other groups are not jumped over.
- The jump target may not be positioned so that other functions are jumped over (e.g. AZP, waiting points, progressive signalling functions, etc.)

From version 6.40 (only for EPB 12 / EPB 24 / EPB 48)

- Extended jump conditions apply from version 6.40. A jump is only permitted if the same signal pattern is present at the time of the request query as in the corresponding target point (additional flashing is permitted). No jump takes place when the signal patterns differ.

Example of permitted jump conditions:

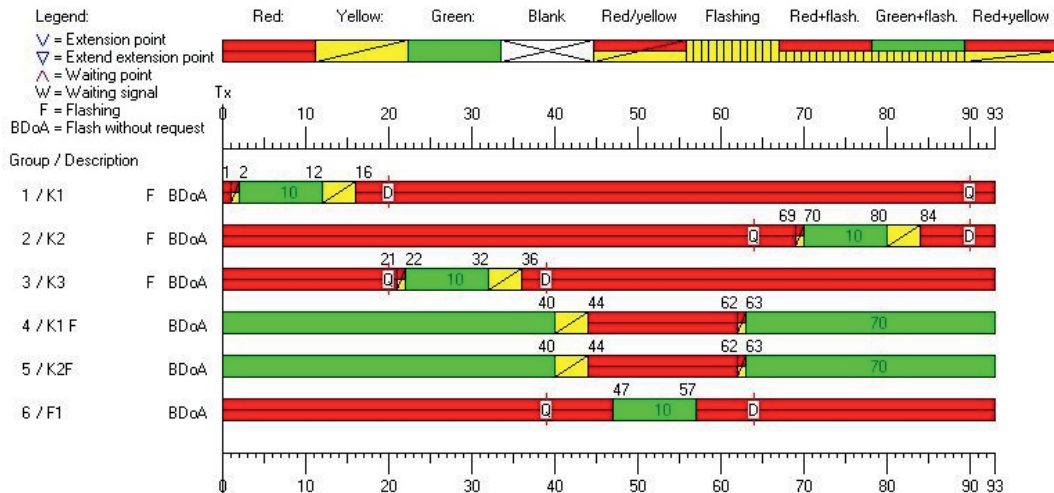

Example of not permitted jump conditions: wrong signal patterns for request query and target for group 6 (F1). The jump from second 38 to second 60 is not carried out.

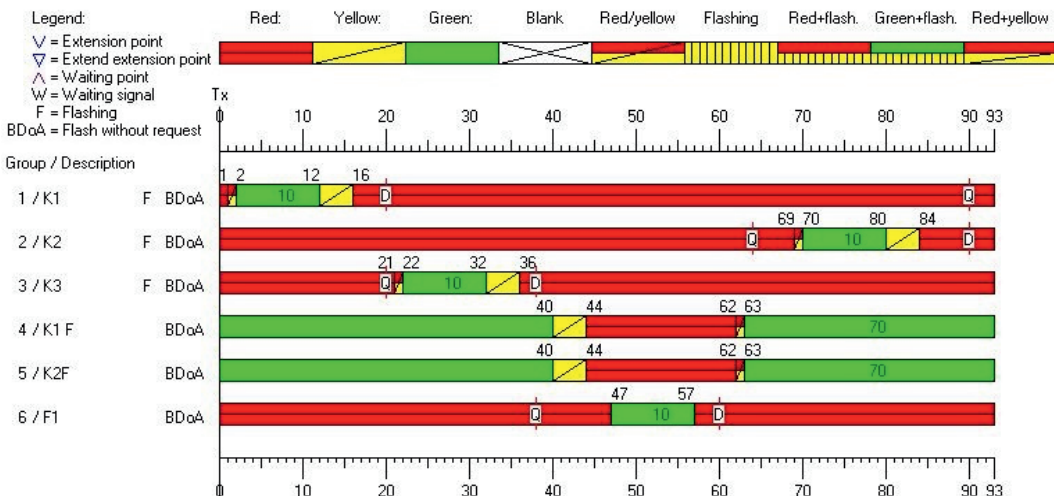

The following jump conditions must be heeded up to and including version 6.32 (only EPB 12 / EPB 24 / EPB 48) and MPB 4xxx:

- A jump is only permitted if CONTINUOUS RED applies at the time of the request query (additional flashing is permitted). No jump takes place for other signal patterns.
- Jump to green is permitted. But it is important to assure that the corresponding target group has the red / green colour sequence. If this is not the case, the controller switches off due to an interim time error.
- A jump is carried out regardless of the signal pattern at the target point. If the jump results in a fault, the controller switches off with the corresponding error.

Example of permitted jump condition in continuous red:

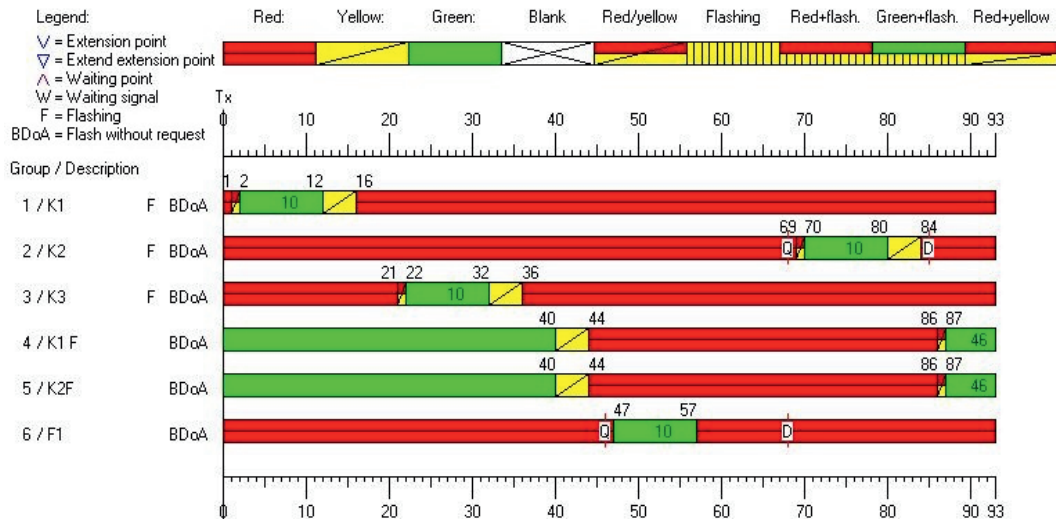

Example of not permitted jump conditions: not in continuous red, jump from second 46 to second 69 is not carried out as group 3 (K3) is at green in the query second (46):

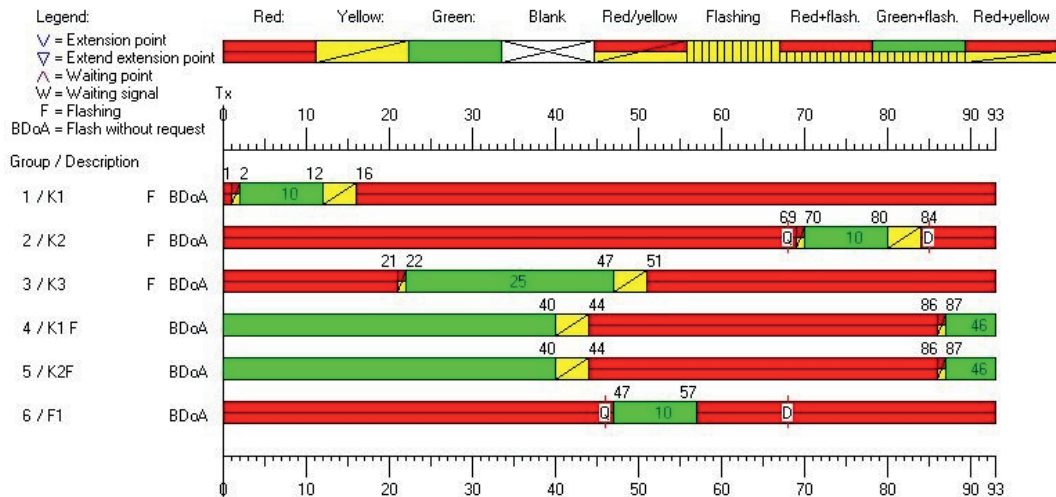

Note:

Maximum two target points can be set per group (not for MPB 4xxx). A target point at second 0 is not possible. If a query point for a request is required at second 0, this must be positioned in the second of the cycle.

Use  to delete individual target points again by simply clicking the mouse button on the corresponding target point.

6.3.6.5 Leave group at green

Use **Verl. DZ** to activate the **Extend large extension time** function for an existing extension point.

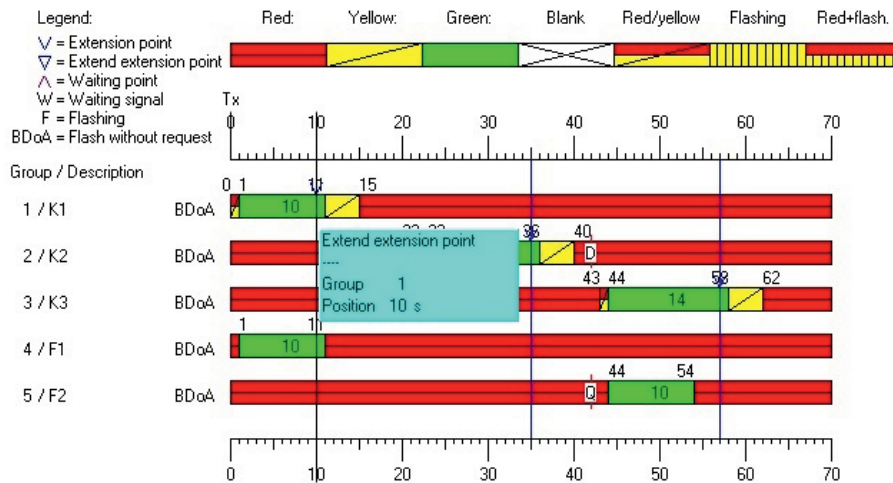

If this function is activated for an extension point, this is shown to be closed and marked with **HP**.

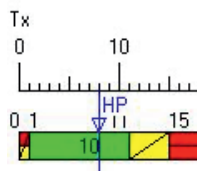

The program remains in this extension point until a request is received for another group, e.g. pedestrian system.

Notes:

- Presets must be disabled in the **Automatic detector presets** mask for groups using special functions (blinker, continuous yellow, continuous red, etc.). Otherwise, the **Extend large extension time** function is disabled again because current presets are only cancelled at green start.
- If the program is in an extension point and a program change is pending, a request is preset for all groups (depending on the requirements for automatic detector presets).

Use **Verl. DZ** to delete these functions again by simply clicking the mouse button on the corresponding extension point.

6.3.6.6 Insert waiting signal

Use **WS** to activate **Waiting signal** for a group: this can then also be used as request confirmation.

If a group switches to a request, this is shown immediately as soon as there is a request for the corresponding group. If this groups comes into the fixed cycle, the system switches immediately after green end.

The waiting signal is deleted automatically at the start of green for the affected group. The waiting signal only appears when the corresponding group is not at green.

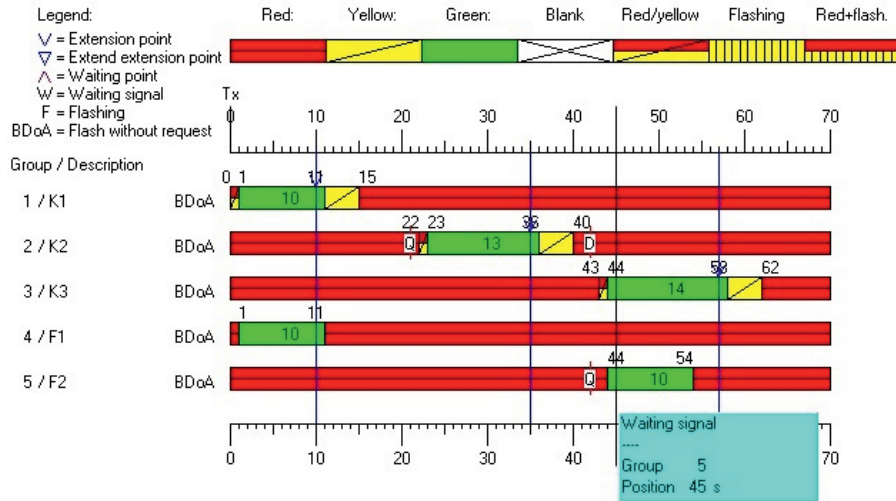

A waiting signal can only be activated in a group if this has no yellow, red-yellow, yellow flashing or continuous yellow phase.

W appears at the start of the green phase for the corresponding group as a visible indication.

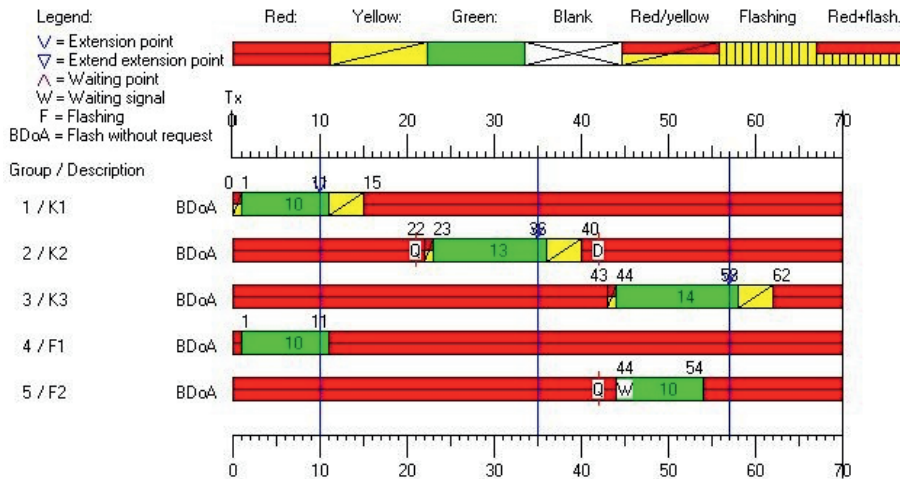

Output waiting signal:

- In EPB controllers, the output of the waiting signal uses the free yellow output of the affected group.
- In MPB 4xxx controllers, the waiting signal is switched via the red 2 output at the parallel signal head output. The signal head must be wired accordingly.

Note:

From software version 6.50 (only EPB 12 / EPB 24 / EPB 48), the waiting signal can also flash as an option.

Use **WS**  to delete these functions again by simply clicking the mouse button on the corresponding waiting signal.

6.3.6.7 Yellow flashing / continuous yellow without request

If a yellow flashing / continuous yellow phase to green has been drawn for a group, it is possible to determine the behaviour of this phase when its green is switched to request. In the default for this function, the yellow flashing / continuous yellow phase is also output when there is no request for this group. For these groups, **BDoA** appears at the start of the intersection time plan as a visible indication.

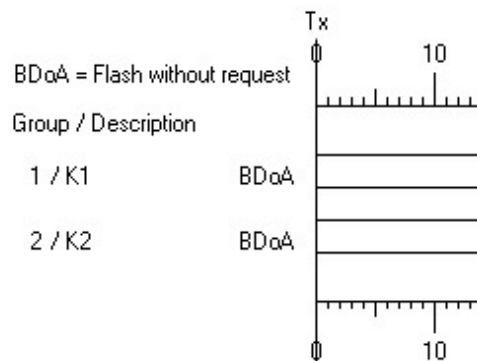

Use **BDoA** to disable this function separately for every group. The yellow flashing / continuous yellow phase is only switched when there is a request for the affected group. **BDoA** at the start of the intersection time plan is then hidden, Click on **BDoA**  to enable the function again.

6.3.7 Progressive signalling

Various functions are available for progressive signalling, depending on the controller. Either cable inputs or a radio clock can be used to synchronise a controller. If the sync. pulse is missing, this is shown by control lamps or in the display, depending on the controller (request 1 or 2 missing). The display goes off again as soon as the corresponding sync. pulse is present.

6.3.7.1 Sync. input 2

Use **Syn 1** to set a waiting point for progressive signalling in an intersection time plan.

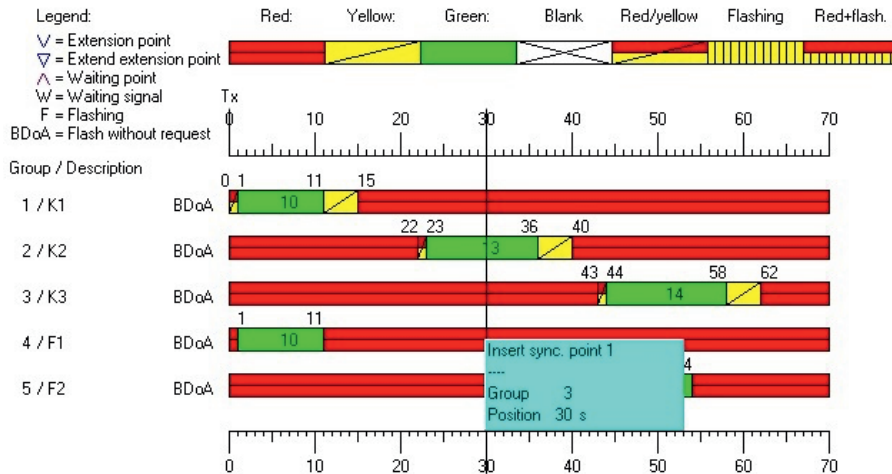

Note:

Radio clocks type BCD only support a cycle time of up to 255 seconds so that a query appears when the sync point is placed at a position larger than 255 seconds:

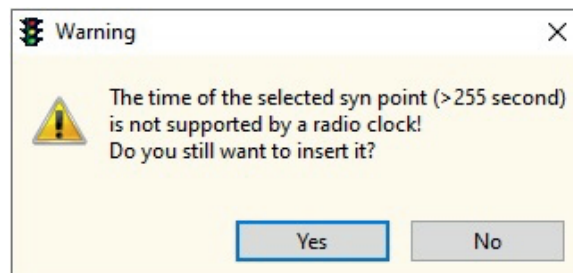

If confirmed with **Yes**, the sync. point is then placed in this position. If the sync. point is to be placed at second 0, it must be placed at the cycle second. Once a sync. point is positioned in the right place, the value appears in the **Syn. 1** box below the editor.

After placing the sync. point, an input window opens automatically to make further mandatory inputs for the respective sync. point. This window also shows the current point in time at which the sync. point was placed.

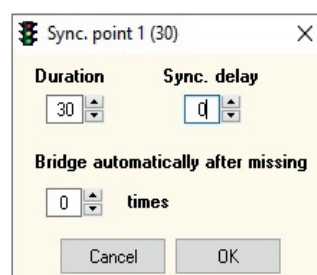

Double click on **Syn. 1** to open this window again for changing the parameters at any time.

Display sync. point 1 set

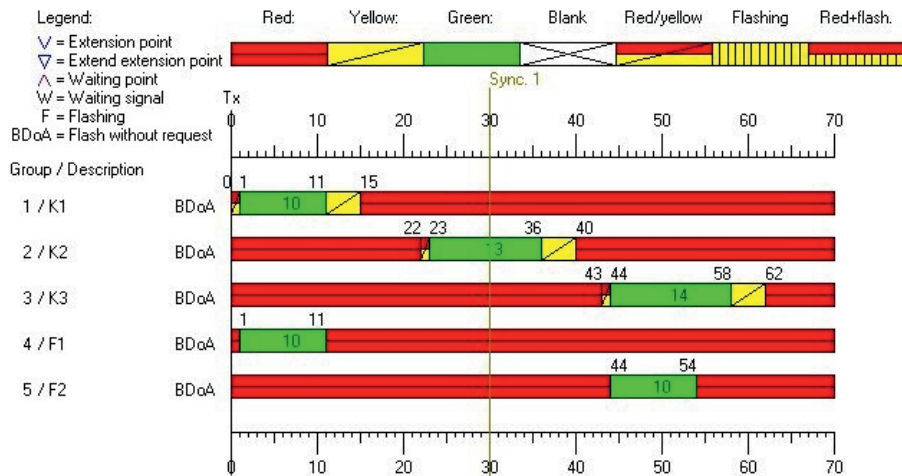

If sync. points are set in the intersection time plan, take the mouse cursor over a sync. point to see more information (duration time, sync. delay and automatic bridging) for the respective sync. point.

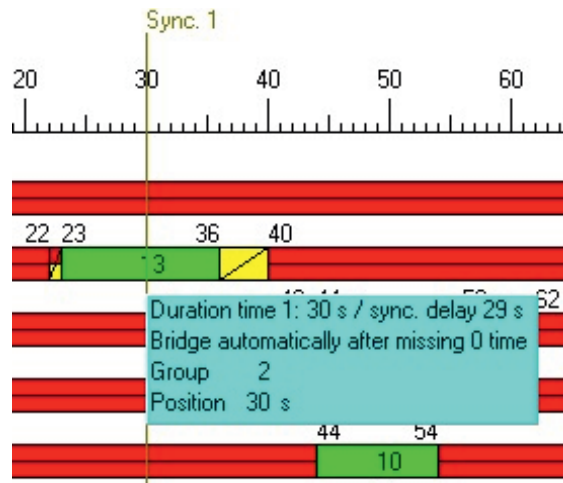

Note:

To delete the sync. point, simply place it at second 0 of the cycle. The following window appears:

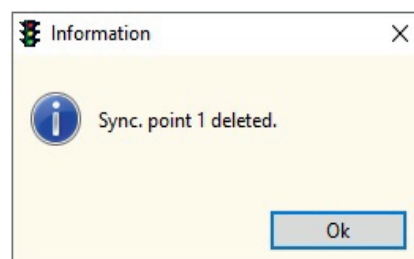

6.3.7.1.1 Duration time sync. input

At the second at which a sync. point has been placed, the controller waits for the corresponding sync. pulse. The duration time stipulates how long the wait lasts. For duration time = 30 s and cycle time 90 s, it takes maximum 3 cycles until the controller is synchronised (the higher the duration time value, the faster the controller is synchronised).

6.3.7.1.2 Sync. delay sync. input

The sync. delay indicates the second at which a sync. delay is carried out. This second is left out of the cycle: instead, the point in time at which the sync. point was placed is doubled. The cycle time thus remains unchanged.

This entry is necessary so that the controller is already in the waiting step before the sync. pulse is present (overlap).

If this function is to be carried out at second 0, the value of the cycle time must be entered.

Note:

The signal pattern at the second with a sync. input delay must correspond to the signal pattern of the corresponding sync. input.

There must not be a red-yellow or yellow phase at this point in time. Also make sure that no other functions (GSP, AZP, etc.) or queries are to be carried out, as these cannot be done then.

If an entry is made for a sync. input delay and no entry for a sync. input, the seconds are jumped over in the cycle and the cycle is shortened accordingly.

The timing of the sync delay must not be one second before a GSP, there must be at least one second between them (sync delay in second 10, GSP in second 12).

6.3.7.1.3 Automatic bridging sync. input

If the controller is synchronised by a cable which no longer switches any progressive signalling pulses (e.g. defective cable), this function can be used to bridge the sync. input automatically.

The value entered for **Bridge automatically after xxx missing** stipulates that the controller should not wait for the duration time after the sync. pulse is missing. The controller then continues to operate normally as soon as the progressive signalling waiting point is reached.

This function is disabled once the synchronisation pulse is present again.

When a radio clock is used for synchronisation, it is usually not necessary to enter this parameter as the radio clock issues the synch. pulse continuously in the event of failure.

Note:

This value can only be entered in program 1. The entered value is just displayed in the other programs.

6.3.7.2 Sync. input 2

Use **Syn 2** to place the values for the second sync. point. See the description for sync. input 1 for instructions and how to enter the additional parameters.

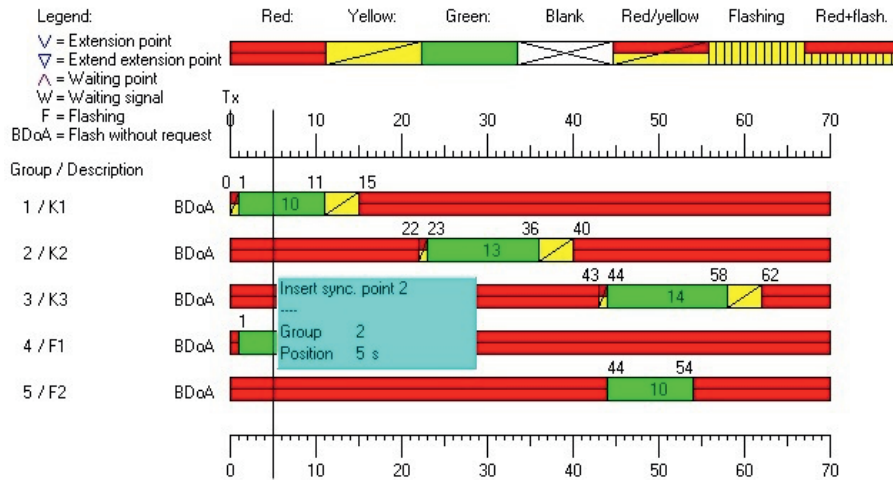

If a second sync. input is used and it remains off, this is shown either in the display or the two lamps **Contr. stands at waiting point** and **Contr. runs to waiting point**.

Note:

A second sync. input is only supported by controllers EPB 12, EPB 24 and EPB 48 with a separate input.

Display sync. point 2 set

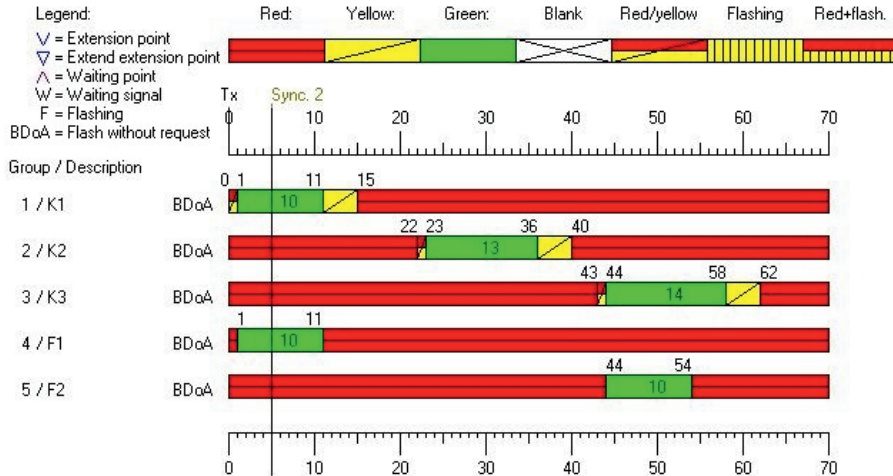

If sync. points are set in the intersection time plan, take the mouse cursor over a sync. point to see more information (duration time, sync. delay and automatic bridging) for the respective sync. point.

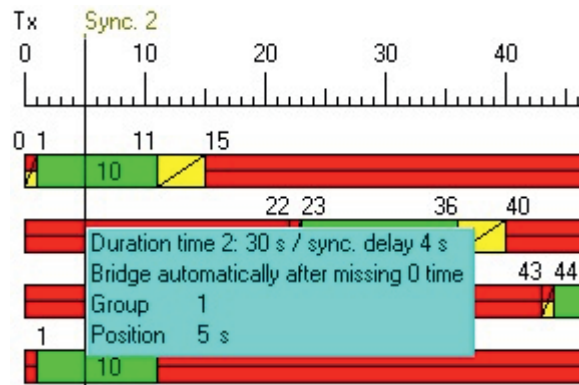

6.3.7.3 Sync. output 1

Use **SynAus 1** to send a sync. pulse (potential-free changeover contact) for synchronising other controllers.

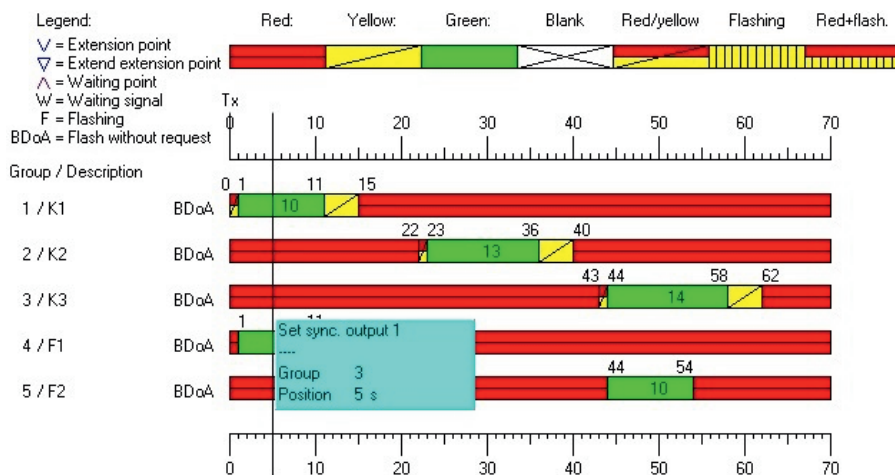

The duration of the sync. pulse is fully variable for controller types EPB 12 / EPB 24 / EPB 48 (controller functions). For all other EPB controllers, the duration is fixed at 2 seconds. From version 6.50 (EPB 12 / EPB 24 / EPB 48) the way the sync. outputs work in the controller functions can be changed. [6.9.1.2](#)

Note:

No sync. output for MPB 4xxx.

6.3.7.4 Sync. output 2

Use **SynAus 2** to send a second sync. pulse. The function corresponds to that of sync. output 1.

Note:

A second sync. output is only supported by controllers EPB 12, EPB 24 and EPB 48.

6.3.7.5 Switch aux. relays

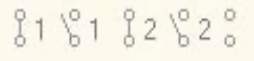
Use  to control the aux. relays of power cards EPB 24 / EPB 48.

Note:

These functions are not yet available and are therefore disabled.

6.3.8 Switch-on programs

There are two variations for creating the switch-on program, depending on controller type:

- switch-on program as program (EPB 12 / EPB 24 / EPB 48).
- switch-on program as steps (MPB 4xxx).

On importing a program (controller type EPB 12 / EPB 24 / EPB 48) with switch-on program in steps, the corresponding editor opens. This version is not available when re-programming these controller types.

The first 15 seconds of the intersection time plan appear to the right of the switch-on program from the ON time (EZP) behind the switch-on program.

This display appears immediately when creating the switch-on program as program (only EPB 12 / EPB 24 / EPB 48). When creating the switch-on program as steps, the display only appears after entering the step duration.

Notes:

- From CPU version 7.10 (EPB 12 / EPB 24 / EPB 48), steps are no longer supported in switch-on programs.
- Depending on the software version set (EPB 12 / EPB 24 / EPB 48), a drawing function for a blank time is displayed.

6.3.8.1 Switch-on program as program (bottleneck)

If the switch-on program is selected and no data have been entered yet, the following query appears:

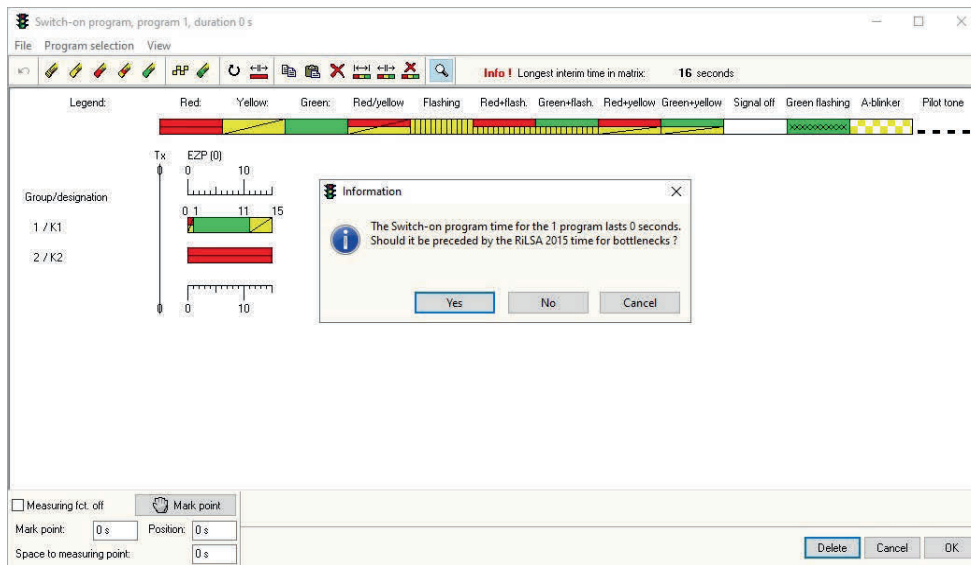

Yes presets the RiLSA 2015 time for bottlenecks as defaults. The total duration is then 4 seconds (yellow VEH) plus the value for the longest interim time.

No opens another dialogue box:

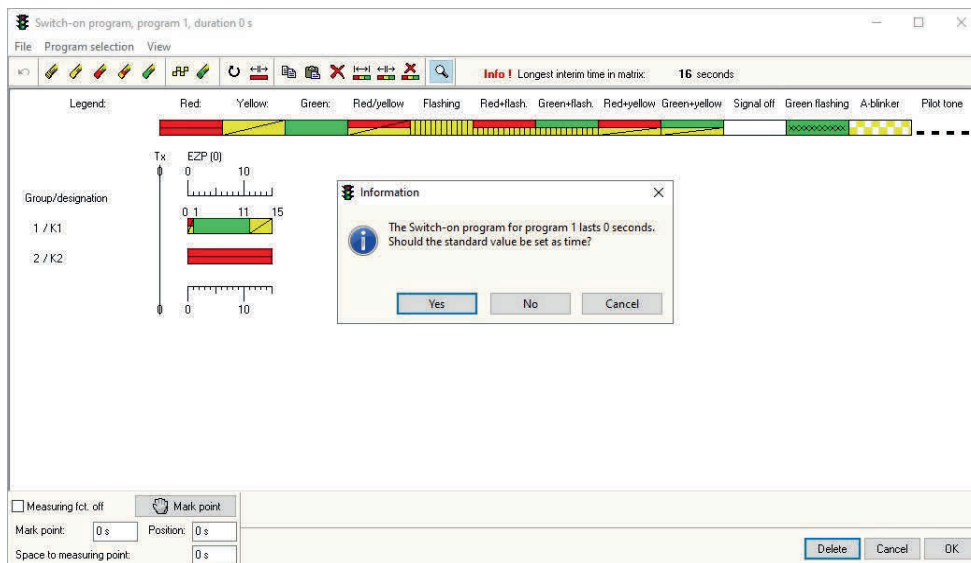

Yes sets the duration of the switch-on flashing program to the value entered in the program settings under cycle time default.

No means that no duration is set for the switch-on program. It is then not possible to create a switch-on program.

6.3.8.2 Switch-on program (larger than bottleneck)

If the switch-on program is selected and no data have been entered yet, the following query appears:

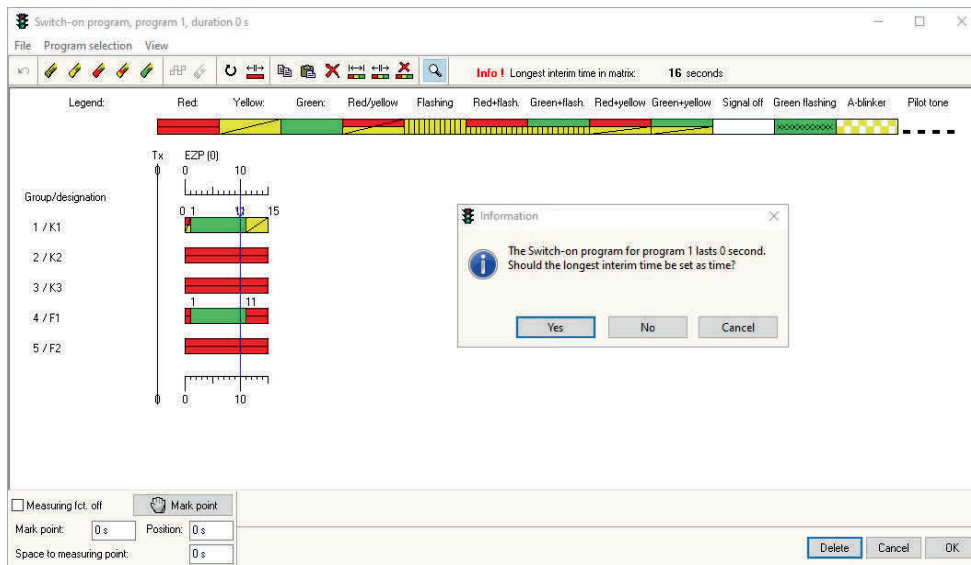

Yes sets the duration for the switch-on program to the highest value in the interim time matrix.

No opens another dialogue box:

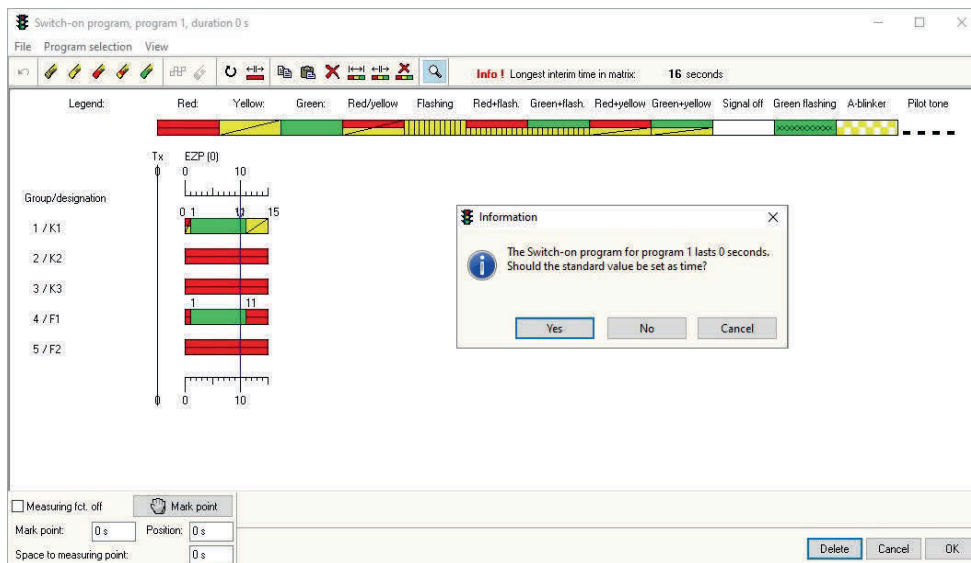

Yes sets the duration of the switch-on program to the value entered in the program settings under cycle time default.

No means that no duration is set for the switch-on program. It is then not possible to create a switch-on program.

The duration of the switch-on program is limited to 240 seconds, depending on the version.

A corresponding message appears on exceeding this value.

If several programs are active, the program choice function is enabled in the menu.

The single-second interval can be adjusted in 3 stages in the View menu.

When the switch-on program editor is closed, the following settings are saved:

- Show phases (green from, green to, continuous green, yellow and red-yellow phases).
- Single-second interval setting.
- Measuring function on or off
- Editor window size.

These functions are preset accordingly every time the switch-on program editor is opened.

Note:

As a rule (as per RiLSA) the duration of the switch-on program should cover the longest interim time.

6.3.8.3 Draw switch-on program as program

The drawing, operating and monitoring functions are the same as for the intersection time plan editor. Colour sequences that are not supported are hidden. **6.3.3**

Every colour is drawn individually. Empty (blank) sections within a group are not filled automatically.

It is not possible to draw a blank phase. Any empty sections in the switch-on program mean that this group remains off (blank) for this time.

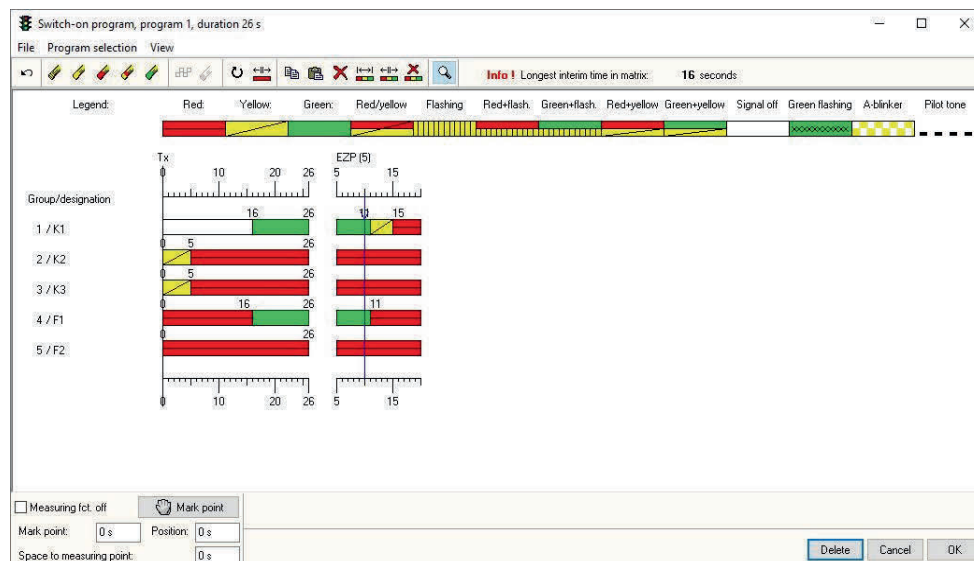
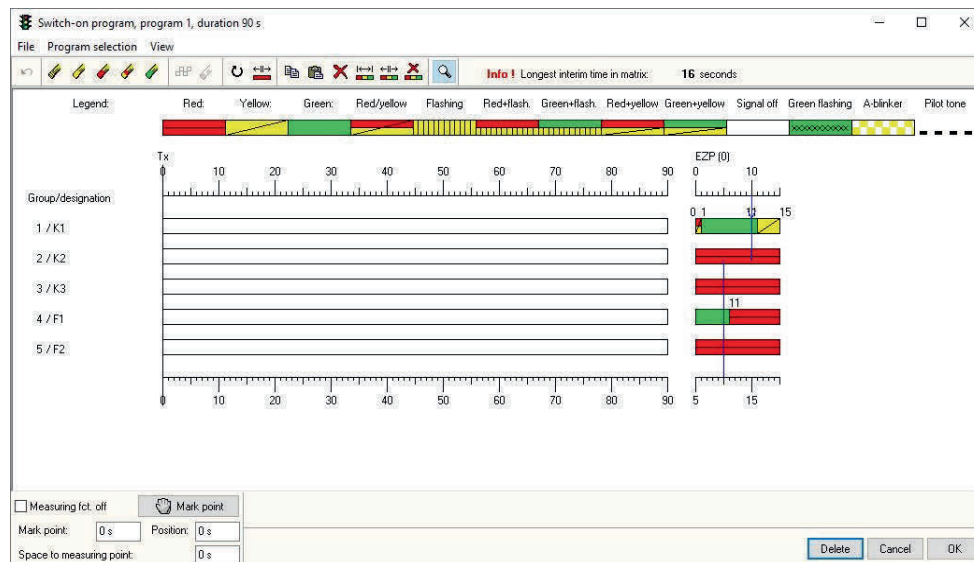

If the mask is closed with **OK**, the system checks whether a switch-on program has been created for all released programs.

Note

To draw green flashing in the switch-on program, see 6.3.4.1.4 (Variable drawing of green flashing)

If this is not the case, the following message appears:

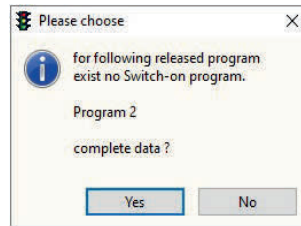

Depending on the confirmation, the editor for the switch-on programs is closed and the data are saved. **Yes** keeps the editor for the switch-on program open and you can make corrections.

6.3.8.4 Switch-on program as steps

After opening the drawing module, a query appears for the time of the individual steps, together with information about the longest interim time from the interim time matrix.

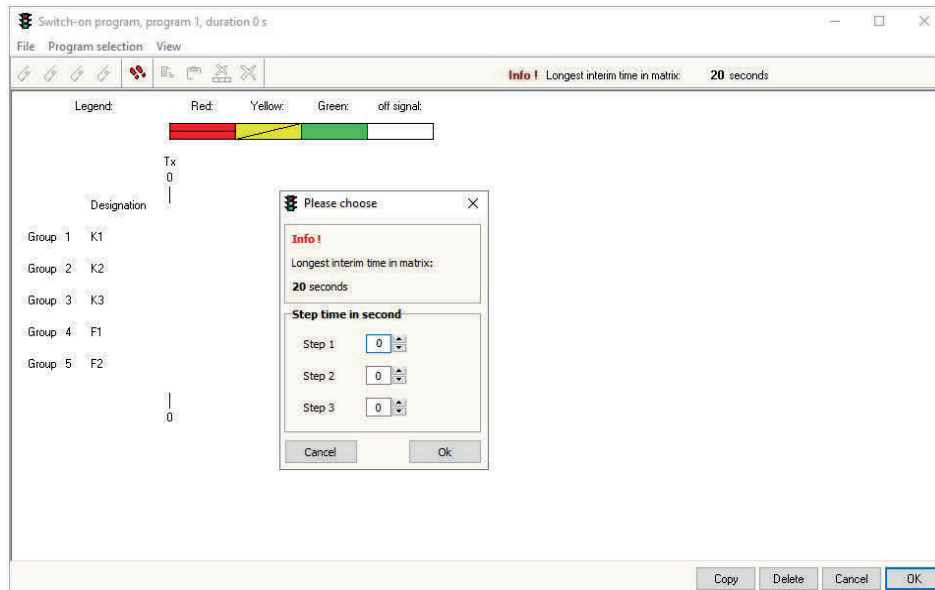

Closing the query window activates the drawing window for the switch-on program. The duration of the switch-on program results from the duration of the individual steps. The individual steps are marked by a dividing line. The current position is shown above the dividing line.

The single-second interval can be adjusted in 3 stages in the **View** menu.

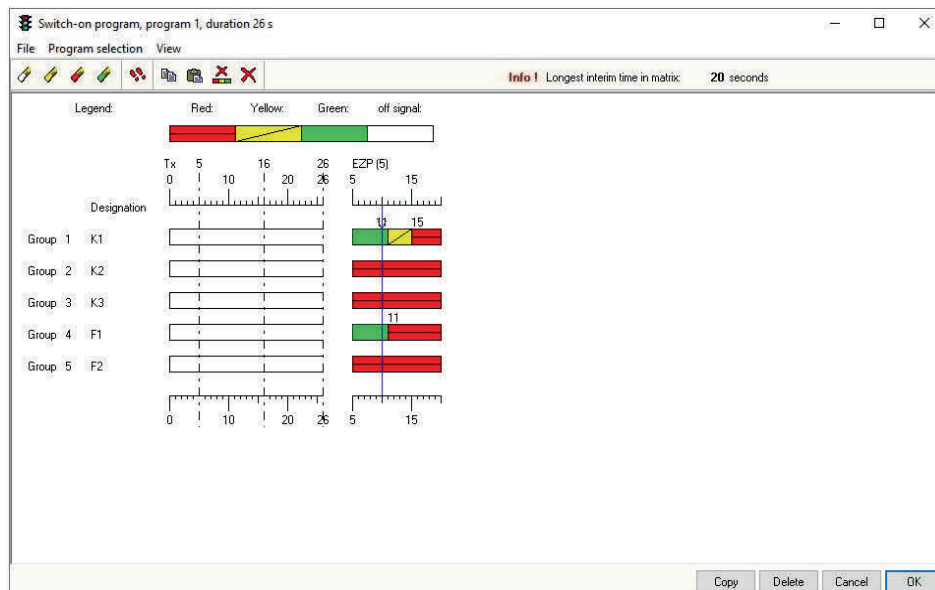

6.3.8.5 Draw switch-on program as steps

The drawing, operating and monitoring functions are the same as for the intersection time plan editor. [6.3.3](#)

Clicking the respective buttons activates the corresponding drawing function.

Clicking the mouse in a step of a group fills the step with the selected colour.

The display size for the signal groups can be adjusted in the View menu.

Use  to extend the step time.

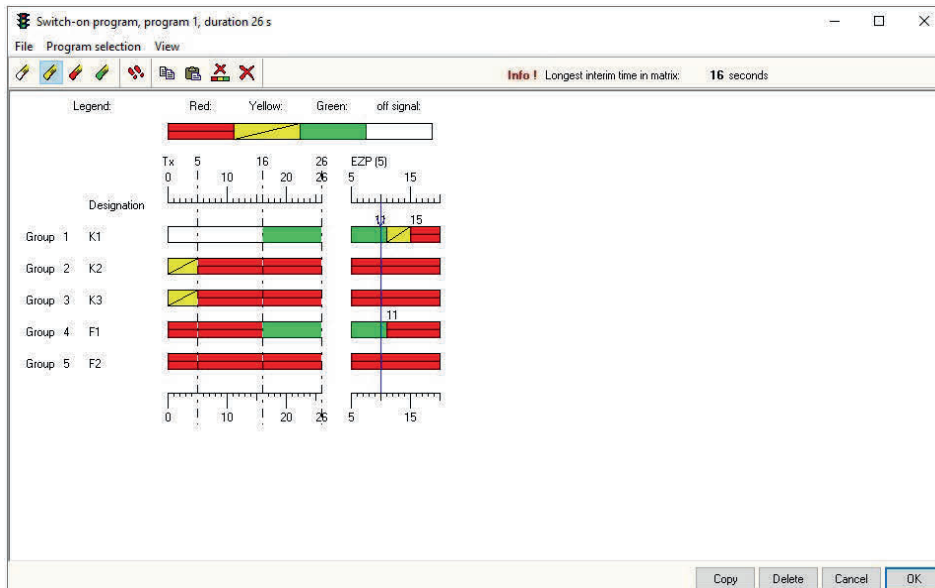
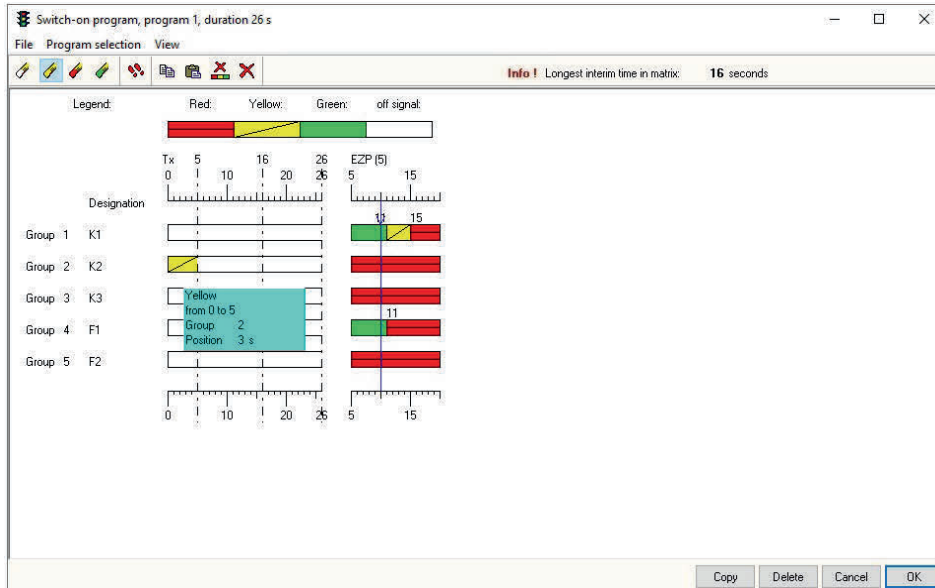

If the mask is closed with **OK**, the system checks whether a switch-on program has been created for all released programs. If this is not the case, the following message appears:

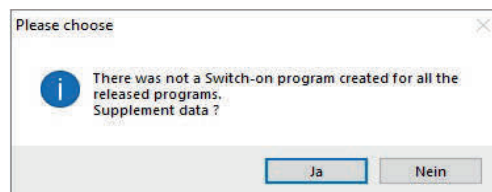

Depending on the confirmation, the editor for the switch-on programs is closed and the data are saved. **Yes** keeps the editor for the switch-on program open and you can make corrections.

6.3.9 Specific switch-off programs

There are two variations for creating the specific switch-off program, depending on controller type:

- switch-off program as program (EPB 12 / EPB 24 / EPB 48).
- switch-off program as steps (MPB 4xxx).

The specific switch-off program does not show the first 15 seconds of the intersection time plan like the switch-on program does. Instead, the last 15 seconds of the intersection time plan before the OFF time (AZP) are shown to the left of the switch-off program.

This display appears immediately when creating the specific switch-off program as program (only EPB 12 / EPB 24 / EPB 48). When creating the switch-off program as steps, the display only appears after entering the step duration.

The specific switch-off program is operated and created in the same way as for the switch-on program.  **6.3.8**

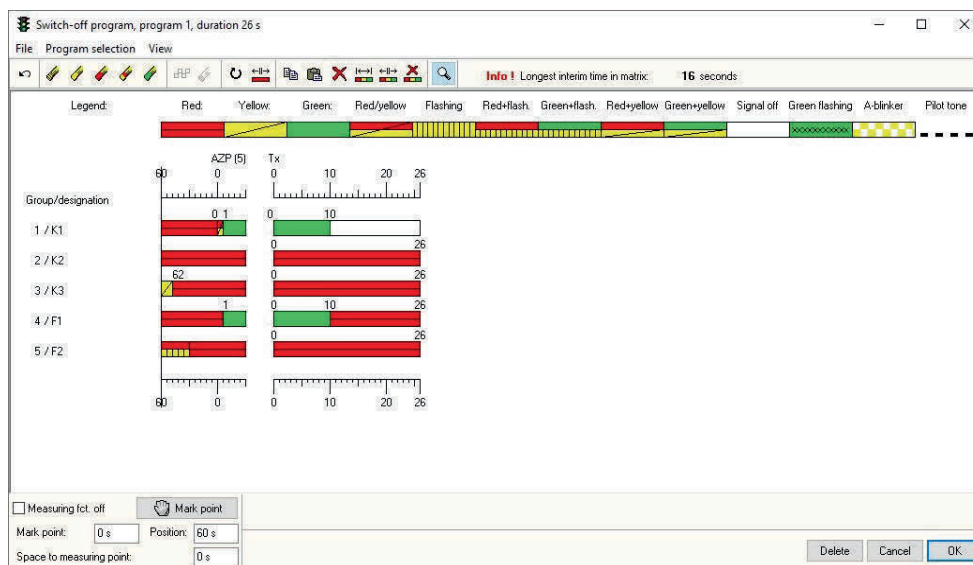

Notes:

- On importing a program (controller type EPB 12 / EPB 24 / EPB 48) with switch-off program in steps, the corresponding editor opens. This version is not available when re-programming these controller types.
- To draw green flashing in the specific switch-off program, see **6.3.4.1.4** (Variable drawing of green flashing)
- From CPU version 7.10 (EPB 12 / EPB 24 / EPB 48), steps are no longer supported in specific switch-off programs.
- Depending on the software version set (EPB 12 / EPB 24 / EPB 48), a drawing function for a blank time is displayed.

6.3.10 Error-off program

The error-off program is created in the same way as the switch-on/off programs. [6.3.8](#), but with the following differences/restrictions:

- An error-off program cannot be created for controller type MPB 4xxx.
- Red phases can be drawn for controller types EPB 12 / EPB 24 / EPB 48. It is **not** possible to select green.
- The last 15 seconds of the intersection time plan do not appear.

In contrast to the switch-on and specific switch-off program, the query only asks whether the time from the program settings should be preset. The time is preset or not, depending on the confirmation.

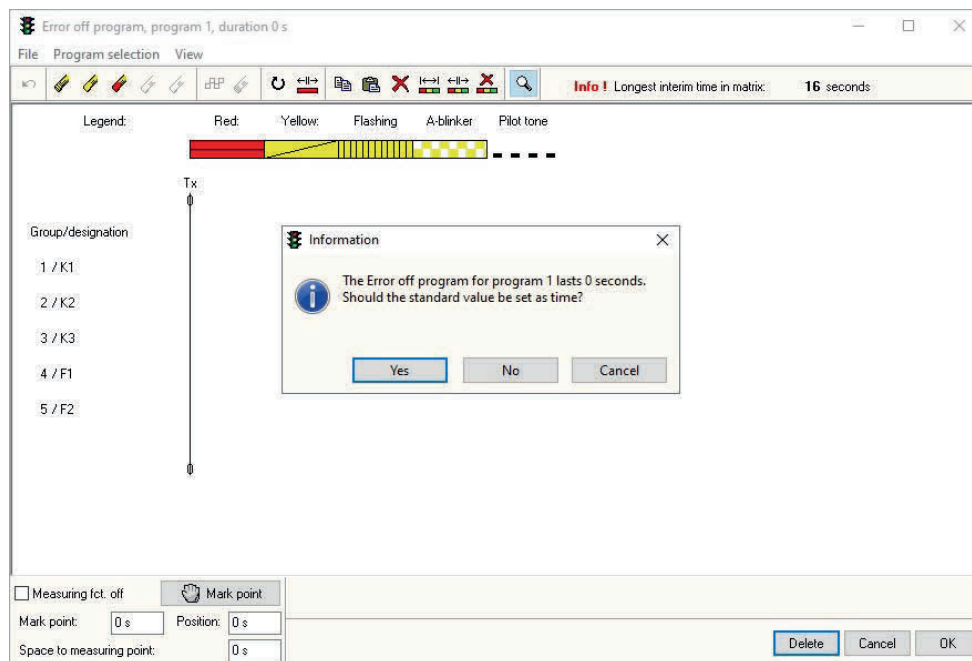

Note:

From CPU version 7.10 (EPB 12 / EPB 24 / EPB 48), steps are no longer supported in error-off programs.

6.3.11 Transition programs

As soon as more than two day programs are enabled, you can use this function to allocate transition programs.

The transition programs are called up when changing program, e.g. when there is no common GSP for a program change.

The corresponding transition program begins as soon as the corresponding GSP of the current program has been reached.

At the end of the transition program, the system goes to the corresponding GSP of the target program.

Note:

This function is only supported from version 7.50 (EPB 12 / EPB 24 / EPB 48).

6.3.11.1 Transition program allocation

Transition program allocation

Transition program:

No.	from	to	Transition program	GSP
1				
2				
3				
4				
5				
6				
7				
8				
9				
10				
11				
12				
13				
14				
15				
16				
17				
18				
19				
20				
21				
22				
23				
24				
25				
26				
27				
28				
29				
30				

Delete Cancel Ok

6.3.11.2 Allocate transition program

Up to 30 transition programs can be allocated.
Click the right mouse button in an empty line to open a selection menu.
Use **"New entry"** to create a new entry: the entry mode appears.

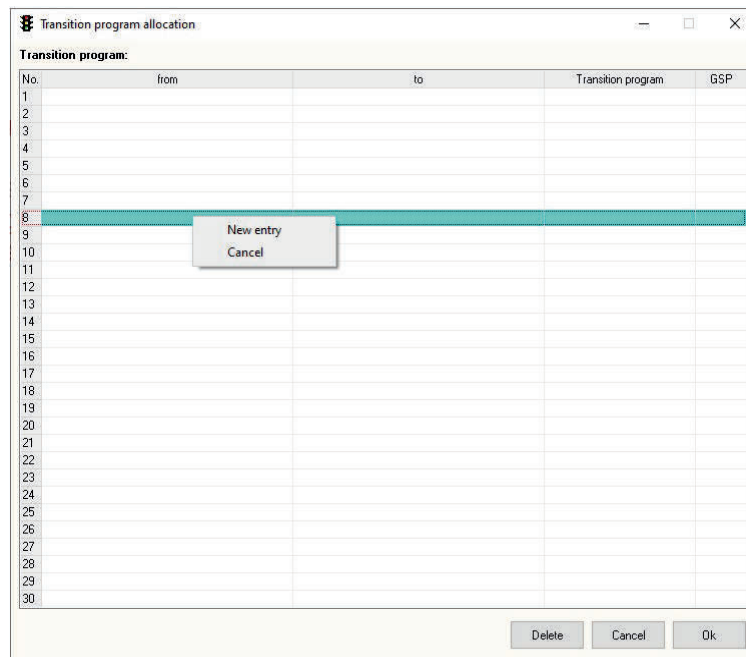

Use the selection boxes to allocate the corresponding transition program. The following entries are necessary:

- used transition program
- program from which the change is being made
- program to which the change is being made
- required GSP

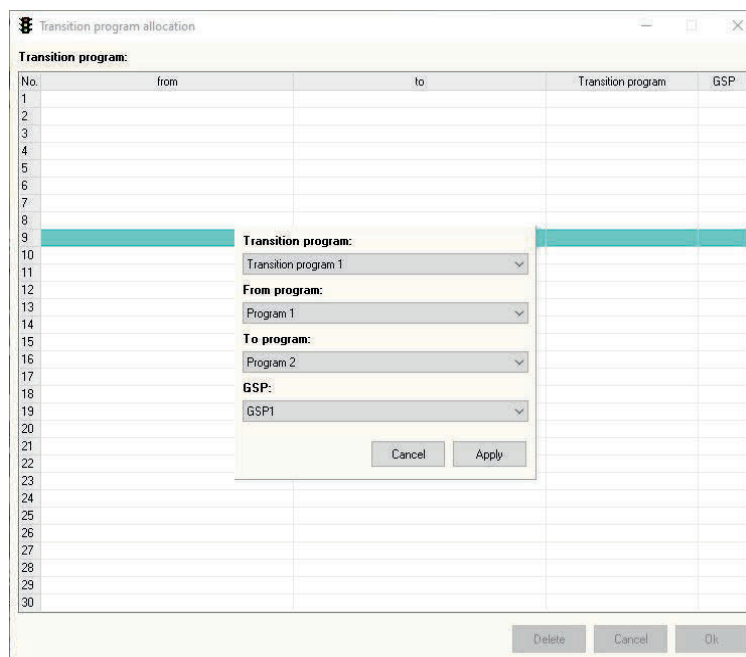

Click on **Save** to save the data and enter them in the list.

The list is sorted automatically. Double entries are not possible.

No.	from	to	Transition program	GSP
1	Program 1	Program 2	Transition program 1	GSP1
2				
3				
4				
5				
6				
7				
8				
9				
10				
11				
12				
13				
14				
15				
16				
17				
18				
19				
20				
21				
22				
23				
24				
25				
26				
27				
28				
29				
30				

Buttons: Delete, Cancel, Ok

6.3.11.3 Edit transition program allocation

To edit an existing entry, mark the entry with the right mouse button and select **“Edit entry”**. Alternatively, simply double click on the corresponding entry. The entry mode appears in both cases.

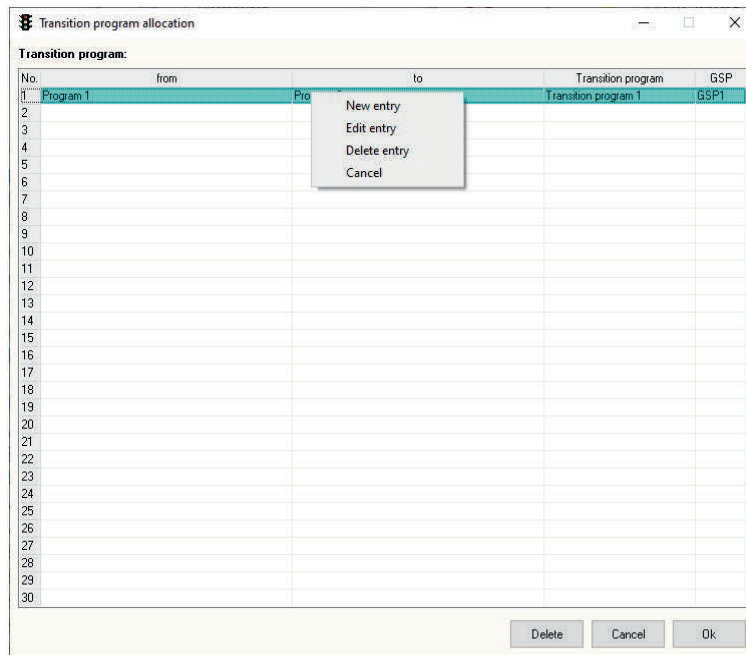

If you select **“Delete entry”**, the marked entry is deleted after a confirmation prompt.

6.3.11.4 Draw transition programs

Handling the editor for the transition programs is the same as handling the editor for the switch-on programs, see point **6.3.8.3**

To check whether the signal pattern of a transition program goes with the corresponding GSPs, select the required combination in the “**Transitions**” selection box.

To the left of the transition program, the last 15 seconds of the program are shown (before GSP) from which the system changes to the transition program.

To the right of the transition program, the first 15 seconds of the program are shown (from GSP) to which the system changes after the end of the transition program.

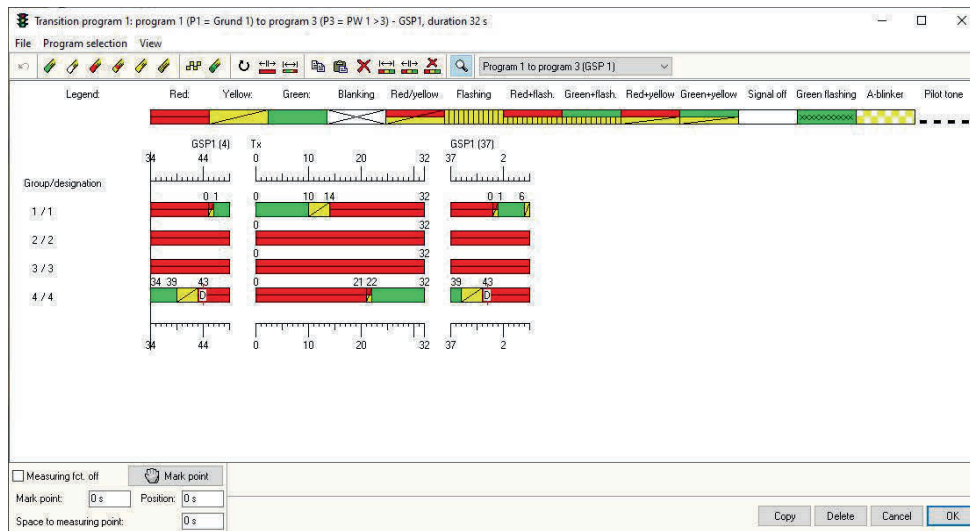

Note:

If no transition program has been allocated, the editor for the transition program is blocked.

6.3.11.5 Special functions Transition programs

- If an assigned transition program is not available, the program change takes place directly from GSP to GSP, error switch-off possible if necessary.
- Requests for special functions are handled as follows:
If a program change has been triggered and a transition program is still active, the set functions (logon, logoff, etc.) of the currently running program apply.
As soon as a transition program is active, the set functions of the program to which the change is made after the end of the transition program apply.

6.4 Special masks

This menu can be used to access special masks for entering special functions.

Note:

The choice varies depending on controller type and version.

6.4.1 Mapping detector inputs

The individual detector inputs are mapped or assigned in this mask.

The entries are adjusted to the selected controller type / version.

Boxes that are not needed are disabled. They are shown cross-hatched.

The number of visible programs changes according to the program release.  6.1.7

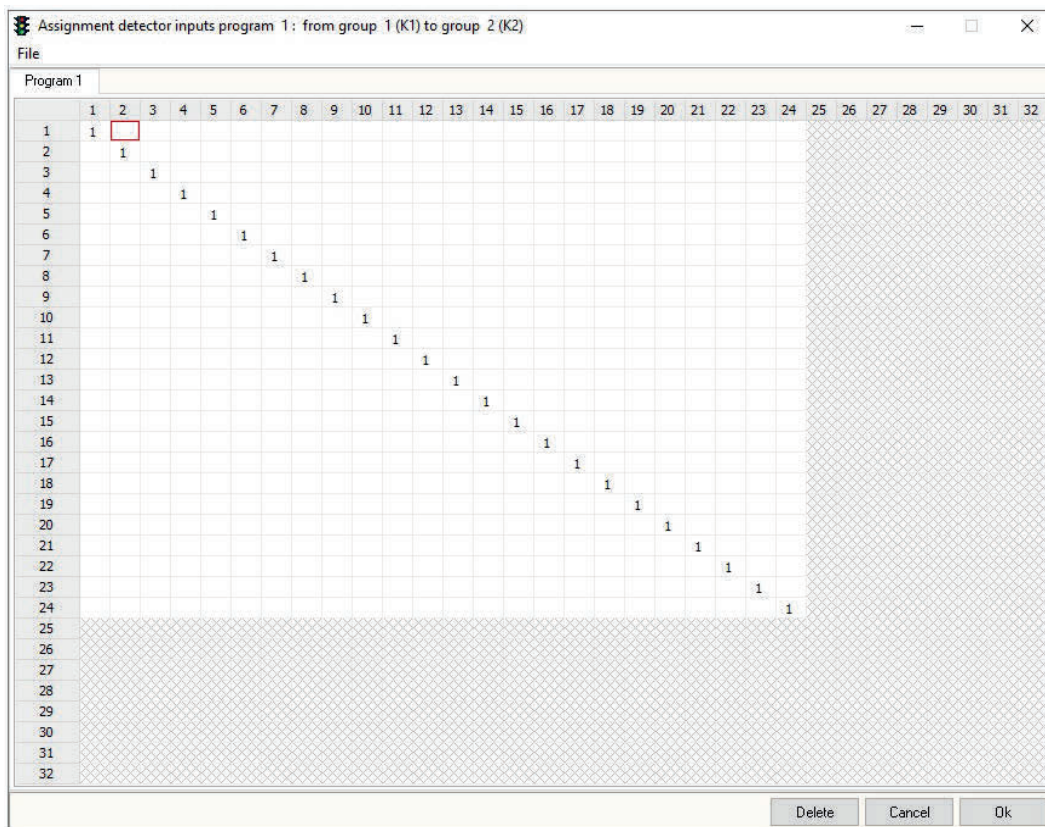

Program 1	1	2	3	4	5	6	7	8	9	10	11	12	13	14	15	16	17	18	19	20	21	22	23	24	25	26	27	28	29	30	31	32
1	1																															
2		1																														
3			1																													
4				1																												
5					1																											
6						1																										
7							1																									
8								1																								
9									1																							
10										1																						
11											1																					
12												1																				
13													1																			
14														1																		
15															1																	
16																1																
17																	1															
18																		1														
19																			1													
20																				1												
21																					1											
22																						1										
23																							1									
24																								1								
25																																
26																																
27																																
28																																
29																																
30																																
31																																
32																																

The entries are made line by line. Line 1 is used to select the groups affected by detector input 1. The second line is for group 2, etc.

Changing the value to 0 disables this detector for this group.

If several detectors are assigned to a group in a line (using the left mouse button), a tick appears accordingly. The function of this mask is not limited to the number of active groups.

Note:

For controller types EPB 12 / EPB 24 / EPB 48, the system only evaluates the detector inputs of the addressed power cards and not any others.

6.4.2 Automatic detector presets

This mask defines which groups have automatic detector presets as a default function for program start, program change, forced cycle and continuous request (control panel). The entries are adjusted to the selected controller type / version. Boxes that are not needed are disabled and shown cross-hatched.

Prg./Grp.	1	2	3	4	5	6	7	8	9	10	11	12	13	14	15	16	17	18	19	20	21	22	23	24
P1	<input checked="" type="checkbox"/>	<input checked="" type="checkbox"/>	<input checked="" type="checkbox"/>	<input checked="" type="checkbox"/>	<input checked="" type="checkbox"/>	<input checked="" type="checkbox"/>	<input checked="" type="checkbox"/>	<input checked="" type="checkbox"/>	<input checked="" type="checkbox"/>	<input checked="" type="checkbox"/>	<input checked="" type="checkbox"/>	<input checked="" type="checkbox"/>	<input checked="" type="checkbox"/>	<input checked="" type="checkbox"/>	<input checked="" type="checkbox"/>	<input checked="" type="checkbox"/>	<input checked="" type="checkbox"/>	<input checked="" type="checkbox"/>	<input checked="" type="checkbox"/>	<input checked="" type="checkbox"/>	<input checked="" type="checkbox"/>	<input checked="" type="checkbox"/>	<input checked="" type="checkbox"/>	<input checked="" type="checkbox"/>
P2	<input checked="" type="checkbox"/>	<input checked="" type="checkbox"/>	<input checked="" type="checkbox"/>	<input checked="" type="checkbox"/>	<input checked="" type="checkbox"/>	<input checked="" type="checkbox"/>	<input checked="" type="checkbox"/>	<input checked="" type="checkbox"/>	<input checked="" type="checkbox"/>	<input checked="" type="checkbox"/>	<input checked="" type="checkbox"/>	<input checked="" type="checkbox"/>	<input checked="" type="checkbox"/>	<input checked="" type="checkbox"/>	<input checked="" type="checkbox"/>	<input checked="" type="checkbox"/>	<input checked="" type="checkbox"/>	<input checked="" type="checkbox"/>	<input checked="" type="checkbox"/>	<input checked="" type="checkbox"/>	<input checked="" type="checkbox"/>	<input checked="" type="checkbox"/>	<input checked="" type="checkbox"/>	<input checked="" type="checkbox"/>
P3	<input checked="" type="checkbox"/>	<input checked="" type="checkbox"/>	<input checked="" type="checkbox"/>	<input checked="" type="checkbox"/>	<input checked="" type="checkbox"/>	<input checked="" type="checkbox"/>	<input checked="" type="checkbox"/>	<input checked="" type="checkbox"/>	<input checked="" type="checkbox"/>	<input checked="" type="checkbox"/>	<input checked="" type="checkbox"/>	<input checked="" type="checkbox"/>	<input checked="" type="checkbox"/>	<input checked="" type="checkbox"/>	<input checked="" type="checkbox"/>	<input checked="" type="checkbox"/>	<input checked="" type="checkbox"/>	<input checked="" type="checkbox"/>	<input checked="" type="checkbox"/>	<input checked="" type="checkbox"/>	<input checked="" type="checkbox"/>	<input checked="" type="checkbox"/>	<input checked="" type="checkbox"/>	<input checked="" type="checkbox"/>
P4	<input checked="" type="checkbox"/>	<input checked="" type="checkbox"/>	<input checked="" type="checkbox"/>	<input checked="" type="checkbox"/>	<input checked="" type="checkbox"/>	<input checked="" type="checkbox"/>	<input checked="" type="checkbox"/>	<input checked="" type="checkbox"/>	<input checked="" type="checkbox"/>	<input checked="" type="checkbox"/>	<input checked="" type="checkbox"/>	<input checked="" type="checkbox"/>	<input checked="" type="checkbox"/>	<input checked="" type="checkbox"/>	<input checked="" type="checkbox"/>	<input checked="" type="checkbox"/>	<input checked="" type="checkbox"/>	<input checked="" type="checkbox"/>	<input checked="" type="checkbox"/>	<input checked="" type="checkbox"/>	<input checked="" type="checkbox"/>	<input checked="" type="checkbox"/>	<input checked="" type="checkbox"/>	<input checked="" type="checkbox"/>
P5	<input checked="" type="checkbox"/>	<input checked="" type="checkbox"/>	<input checked="" type="checkbox"/>	<input checked="" type="checkbox"/>	<input checked="" type="checkbox"/>	<input checked="" type="checkbox"/>	<input checked="" type="checkbox"/>	<input checked="" type="checkbox"/>	<input checked="" type="checkbox"/>	<input checked="" type="checkbox"/>	<input checked="" type="checkbox"/>	<input checked="" type="checkbox"/>	<input checked="" type="checkbox"/>	<input checked="" type="checkbox"/>	<input checked="" type="checkbox"/>	<input checked="" type="checkbox"/>	<input checked="" type="checkbox"/>	<input checked="" type="checkbox"/>	<input checked="" type="checkbox"/>	<input checked="" type="checkbox"/>	<input checked="" type="checkbox"/>	<input checked="" type="checkbox"/>	<input checked="" type="checkbox"/>	<input checked="" type="checkbox"/>
P6	<input checked="" type="checkbox"/>	<input checked="" type="checkbox"/>	<input checked="" type="checkbox"/>	<input checked="" type="checkbox"/>	<input checked="" type="checkbox"/>	<input checked="" type="checkbox"/>	<input checked="" type="checkbox"/>	<input checked="" type="checkbox"/>	<input checked="" type="checkbox"/>	<input checked="" type="checkbox"/>	<input checked="" type="checkbox"/>	<input checked="" type="checkbox"/>	<input checked="" type="checkbox"/>	<input checked="" type="checkbox"/>	<input checked="" type="checkbox"/>	<input checked="" type="checkbox"/>	<input checked="" type="checkbox"/>	<input checked="" type="checkbox"/>	<input checked="" type="checkbox"/>	<input checked="" type="checkbox"/>	<input checked="" type="checkbox"/>	<input checked="" type="checkbox"/>	<input checked="" type="checkbox"/>	<input checked="" type="checkbox"/>
P7	Cross-hatched																							
P8	Cross-hatched																							
P9	Cross-hatched																							
P10	Cross-hatched																							
P11	Cross-hatched																							
P12	Cross-hatched																							

Note:

The mask has no influence on the function for program change on request which is only triggered directly by detector inputs.

6.4.3 Delete request presets

This mask defines the groups for which requests prestests should be deleted. These are deleted for every program start, program change and possibly after ending continuous red / preemption. The entries are adjusted to the selected controller type / version. Boxes that are not needed are disabled and shown cross-hatched.

Prg./Grp.	1	2	3	4	5	6	7	8	9	10	11	12	13	14	15	16	17	18	19	20	21	22	23	24
P1	<input type="checkbox"/>																							
P2																								
P3																								
P4																								
P5																								
P6																								
P7	Cross-hatched																							
P8	Cross-hatched																							
P9	Cross-hatched																							
P10	Cross-hatched																							
P11	Cross-hatched																							
P12	Cross-hatched																							

Note:

This function is only available for controller type EPB 12 / EPB 24 / EPB 48 from version 6.80.

6.4.4 Delete linked requests with green

Here you can stipulate the groups where linked requests made during the green phase are deleted.

In the default setting, all requests are deleted with green.

In special cases (e.g. groups that switch to green together but **stop** separately), requests made with **"Allocate detector inputs"** are deleted for groups switching to red later. Disable the ticks for the groups where this deleting should no longer take place.

Requests from the group switching earlier to red are not deleted in the group switching later to red. Both groups then switch to green at the defined time.

Prg./Grp	1	2	3	4	5	6	7	8	9	10	11	12	13	14	15	16	17	18	19	20	21	22	23	24
P1	<input checked="" type="checkbox"/>	<input checked="" type="checkbox"/>	<input checked="" type="checkbox"/>	<input checked="" type="checkbox"/>	<input checked="" type="checkbox"/>	<input checked="" type="checkbox"/>	<input checked="" type="checkbox"/>	<input checked="" type="checkbox"/>	<input checked="" type="checkbox"/>	<input checked="" type="checkbox"/>	<input checked="" type="checkbox"/>	<input checked="" type="checkbox"/>	<input checked="" type="checkbox"/>	<input checked="" type="checkbox"/>	<input checked="" type="checkbox"/>	<input checked="" type="checkbox"/>	<input checked="" type="checkbox"/>	<input checked="" type="checkbox"/>	<input checked="" type="checkbox"/>	<input checked="" type="checkbox"/>	<input checked="" type="checkbox"/>	<input checked="" type="checkbox"/>	<input checked="" type="checkbox"/>	<input checked="" type="checkbox"/>
P2	<input checked="" type="checkbox"/>	<input checked="" type="checkbox"/>	<input checked="" type="checkbox"/>	<input checked="" type="checkbox"/>	<input checked="" type="checkbox"/>	<input checked="" type="checkbox"/>	<input checked="" type="checkbox"/>	<input checked="" type="checkbox"/>	<input checked="" type="checkbox"/>	<input checked="" type="checkbox"/>	<input checked="" type="checkbox"/>	<input checked="" type="checkbox"/>	<input checked="" type="checkbox"/>	<input checked="" type="checkbox"/>	<input checked="" type="checkbox"/>	<input checked="" type="checkbox"/>	<input checked="" type="checkbox"/>	<input checked="" type="checkbox"/>	<input checked="" type="checkbox"/>	<input checked="" type="checkbox"/>	<input checked="" type="checkbox"/>	<input checked="" type="checkbox"/>	<input checked="" type="checkbox"/>	<input checked="" type="checkbox"/>
P3	<input checked="" type="checkbox"/>	<input checked="" type="checkbox"/>	<input checked="" type="checkbox"/>	<input checked="" type="checkbox"/>	<input checked="" type="checkbox"/>	<input checked="" type="checkbox"/>	<input checked="" type="checkbox"/>	<input checked="" type="checkbox"/>	<input checked="" type="checkbox"/>	<input checked="" type="checkbox"/>	<input checked="" type="checkbox"/>	<input checked="" type="checkbox"/>	<input checked="" type="checkbox"/>	<input checked="" type="checkbox"/>	<input checked="" type="checkbox"/>	<input checked="" type="checkbox"/>	<input checked="" type="checkbox"/>	<input checked="" type="checkbox"/>	<input checked="" type="checkbox"/>	<input checked="" type="checkbox"/>	<input checked="" type="checkbox"/>	<input checked="" type="checkbox"/>	<input checked="" type="checkbox"/>	<input checked="" type="checkbox"/>
P4	<input checked="" type="checkbox"/>	<input checked="" type="checkbox"/>	<input checked="" type="checkbox"/>	<input checked="" type="checkbox"/>	<input checked="" type="checkbox"/>	<input checked="" type="checkbox"/>	<input checked="" type="checkbox"/>	<input checked="" type="checkbox"/>	<input checked="" type="checkbox"/>	<input checked="" type="checkbox"/>	<input checked="" type="checkbox"/>	<input checked="" type="checkbox"/>	<input checked="" type="checkbox"/>	<input checked="" type="checkbox"/>	<input checked="" type="checkbox"/>	<input checked="" type="checkbox"/>	<input checked="" type="checkbox"/>	<input checked="" type="checkbox"/>	<input checked="" type="checkbox"/>	<input checked="" type="checkbox"/>	<input checked="" type="checkbox"/>	<input checked="" type="checkbox"/>	<input checked="" type="checkbox"/>	<input checked="" type="checkbox"/>
P5	<input checked="" type="checkbox"/>	<input checked="" type="checkbox"/>	<input checked="" type="checkbox"/>	<input checked="" type="checkbox"/>	<input checked="" type="checkbox"/>	<input checked="" type="checkbox"/>	<input checked="" type="checkbox"/>	<input checked="" type="checkbox"/>	<input checked="" type="checkbox"/>	<input checked="" type="checkbox"/>	<input checked="" type="checkbox"/>	<input checked="" type="checkbox"/>	<input checked="" type="checkbox"/>	<input checked="" type="checkbox"/>	<input checked="" type="checkbox"/>	<input checked="" type="checkbox"/>	<input checked="" type="checkbox"/>	<input checked="" type="checkbox"/>	<input checked="" type="checkbox"/>	<input checked="" type="checkbox"/>	<input checked="" type="checkbox"/>	<input checked="" type="checkbox"/>	<input checked="" type="checkbox"/>	<input checked="" type="checkbox"/>
P6	<input checked="" type="checkbox"/>	<input checked="" type="checkbox"/>	<input checked="" type="checkbox"/>	<input checked="" type="checkbox"/>	<input checked="" type="checkbox"/>	<input checked="" type="checkbox"/>	<input checked="" type="checkbox"/>	<input checked="" type="checkbox"/>	<input checked="" type="checkbox"/>	<input checked="" type="checkbox"/>	<input checked="" type="checkbox"/>	<input checked="" type="checkbox"/>	<input checked="" type="checkbox"/>	<input checked="" type="checkbox"/>	<input checked="" type="checkbox"/>	<input checked="" type="checkbox"/>	<input checked="" type="checkbox"/>	<input checked="" type="checkbox"/>	<input checked="" type="checkbox"/>	<input checked="" type="checkbox"/>	<input checked="" type="checkbox"/>	<input checked="" type="checkbox"/>	<input checked="" type="checkbox"/>	<input checked="" type="checkbox"/>
P7																								
P8																								
P9																								
P10																								
P11																								
P12																								

Note:

This function is only available for controller type EPB 12 / EPB 24 / EPB 48 from version 7.10

6.4.4 Switch max. green

This function is currently a work in progress and will be made available in one of the next versions.

6.4.5 Set continuous requests

This function is currently a work in progress and will be made available in one of the next versions.

6.4.6 Switch max. extension time extension point 1

This function is currently a work in progress and will be made available in one of the next versions.

6.4.7 Switch max. extension time extension point 2

This function is currently a work in progress and will be made available in one of the next versions.

6.4.8 Set detector inputs

This function is currently a work in progress and will be made available in one of the next versions.

6.4.9 Suppress request

This mask can be used to delete and buffer requests that occur during ongoing operation.

Program 1

Activate by detector input

No.	1	2	3	4	5	6	7	8	9	10	11	12	13	14	15	16	17	18	19	20	21	22	23	24
	<input checked="" type="checkbox"/>																							

Suppress requests at group

No.	1	2	3	4	5	6	7	8	9	10	11	12	13	14	15	16	17	18	19	20	21	22	23	24

Deactivate by detector input

No.	1	2	3	4	5	6	7	8	9	10	11	12	13	14	15	16	17	18	19	20	21	22	23	24

Automatic deactivate function

Automatically deactivate after seconds

Request lock

seconds

Deactivate function in circulation second

Program 1	<input type="text" value="0"/>	Program 2	<input type="text" value="0"/>	Program 3	<input type="text" value="0"/>	Program 4	<input type="text" value="0"/>	Program 5	<input type="text" value="0"/>	Program 6	<input type="text" value="0"/>
Program 7	<input type="text" value="0"/>	Program 8	<input type="text" value="0"/>	Program 9	<input type="text" value="0"/>	Program 10	<input type="text" value="0"/>	Program 11	<input type="text" value="0"/>	Program 12	<input type="text" value="0"/>

Delete Cancel OK

Note:

This function is only supported from version 7.40 (EPB 12 / EPB 24 / EPB 48).
The number of visible programs changes according to the program release. 6.1.7

6.4.9.1 Activate the suppress request function

Use **Activate function** to adjust detector inputs for switching on the suppress request function. Select the groups where a request is to be deleted and buffered in **Suppress request for group**. For these groups, requests are not processed and only buffered until the function is deactivated again.

6.4.9.2 Deactivate the suppress request function

Use **Deactivate function** to adjust the detector inputs for switching the suppress request function off again.

As an alternative, the function can also be switched off automatically after an adjustable time. The time is entered in **Automatically deactivate after xx seconds**.

The time counter for automatic deactivation starts immediately (when triggered).

If there is a program change in this status and the value for Automatically deactivate after xx seconds is higher in the new program, this value is taken as maximum value for the clear-down counter.

6.4.9.3 Deactivate the suppress request function in cycle second

As an alternative, the suppress request function can also be ended at a fixed second in the respective program.

Notes:

- It is possible to combine the various options for switching off the suppress request function.
- As soon as the suppress request function is deactivated, the requests are processed again for all groups (groups switch to green).
- If no function is selected to deactivate the suppress request function, this is only deactivated after a reset or if the controller is rebooted.
From CPU version 7.00, in this case the contact control function is carried out.

☞ 6.4.9.5

6.4.9.4 Blocking time

Here you can activate a request blocking time (1 - 999 seconds) which is deactivated when set to 0.

If this function is activated, renewed activation of the suppress request function is blocked for this time and cannot be processed again until this time has expired.

The request blocking time begins immediately after clear-down of the suppress request function.

6.4.9.5 Suppress request by contact control

For contact control to be carried out, no clear-down function (detector inputs, clear-down in second, deactivate automatically after time) may be present in the respective program.

How it works:

As soon as one of the defined inputs that trigger the suppress request function is in use, this function is not ended again until there is no longer any signal present at these inputs.

6.4.10 Program change on request EPB

The settings for an external program change (detector, push-button, etc.) are adjusted in this mask. When a request comes, the system changes to the requested program. Changing back is implemented by a detector input or by a release in the program. The entries are adjusted to the selected controller type / version. Boxes that are not needed are disabled and shown cross-hatched.

The screenshot shows a configuration window titled "Program change on request : group 1 (K1)". It is split into two main sections: "Login" and "Logout".

Login Section:

- A grid with 12 rows (Program 1-12) and 24 columns (1-24). A small red box is visible in the cell for Program 1, column 1.
- Below the grid, rows 7-12 are cross-hatched.
- Controls for "Release in seconds" and "Change to" (dropdown menu) are provided for P1 through P12.
- A "Request lock" field is set to 0 seconds.

Logout Section:

- A similar grid to the Login section.
- Below the grid, rows 7-12 are cross-hatched.
- Controls for "Logout in seconds" and "Deregistration after time" are provided for P1 through P12.

At the bottom of the window are buttons for "Delete", "Cancel", and "Ok".

6.4.10.1 Request program change on request EPB

In the top table, choose the detector inputs to trigger a program change in this program (a tick appears).

The requested target program is entered in the selection menu **Change to**.

The entries made in the **Release in seconds** box defines the point in time when program change is released in a program. If a value is entered here, when a request comes, the system takes the next additional GSP2 - 6 (intersection time plan editor) found from this second in the cycle.

If 0 is entered here, the release is effective immediately. When a request comes, the system takes the next additional GSP2 - 6 (intersection time plan editor) to be found.

Notes:

- Only the additional GSP 2 - 6 are taken for program change on request.
- To change to the requested program, this also must have been released (basic data - program release).
- The additional GSPs may not be set to the GSP1 (enter programs) as they are then not carried out.

6.4.10.1 Request block

Here you can activate a request block (1 - 999 seconds) which is deactivated when set to 0. If this function is activated, a renewed request for a program change on request is blocked for this time and cannot be processed again until this time has expired. The request block time begins immediately after cleardown of a program change on request.

Note:

This function is only supported from version 7.20 (EPB 12 / EPB 24 / EPB 48).

6.4.10.2 Cleardown for program change on request EPB

As for the request function, in the bottom table choose the detector inputs that release the change back to the currently active program.

The change back can also be released at any second in the respective program. The entry is made separately for every program in the seconds box for the respective program.

The change back then takes place at the next GSP2 – 6 to be found.

Note:

If no cleardown is entered, the system does not change back to the currently active program. In a program, a detector input can only be selected for request or for cleardown (locked against each other).

6.4.10.2.1 Cleardown for program change on request EPB after time

If you want cleardown for a program change on request after time, please enter the required time in the corresponding input boxes.

The time for automatic cleardown begins as soon as the target program is active.

Note:

This function is only supported from version 7.20 (EPB 12 / EPB 24 / EPB 48).

6.4.10.3 Subsequent request for program change on request EPB

To make a subsequent request for a program change on request, the detector inputs requesting the program change must be entered in the program to which the change should be made.

The system then only remains in the program if there is no cleardown using a detector input or release in this program.

From CPU version 7.00, in this case the contact control function is carried out. ☞ **6.4.10.4**

6.4.10.4 Program change on request EPB per contact control

From CPU version 7.00, program change on request can be carried out with contact control. For contact control to be carried out, no cleardown function (detector inputs, cleardown in second, cleardown after time) may be present in the program to which the system is to change.

How it works:

As soon as one of the defined inputs that trigger program change on request is in use, the system changes to the previously stipulated program. The controller then remains in this program until there is no longer any signal at these inputs.

6.4.11 Program change on request MPB 4xxx

This mask is used to adjust the settings for an external program change using detector inputs. This function is supported from version 6.00 in MPB 4xxx.

The entries are adjusted to the selected controller type (radio / cable). Boxes that are not needed are disabled and shown cross-hatched.

At least two suitable programs must be released to make the entry mask accessible in the **Special masks** menu.

Program change on request is always from program 1 to program 2, respectively from program 3 to program 4. Programs 1 and 3 are the basic programs in each case. Programs 2 and 4 are the corresponding special programs.

If a program change on request is active and the controller is in a special program, a regular program change (clock mode / manual selection) only takes place if program change on request has been finished. Regular program changes always take place in the basic programs (1 or 3). There are two input blocks for each program change on request. Entry is enabled when the program is released accordingly.

The screenshot shows a configuration window for 'Program change on request : group 1 (K1)'. It is divided into two main sections: 'Program change from program 1 to program 2' and 'Program change from program 3 to program 4'. Each section contains two sub-sections: 'Activation by' and 'Logout program X either by'. The 'Activation by' sub-sections include a 'Detector input' field with a grid of 12 buttons (1-12) and a 'Request' checkbox. The 'Logout program X either by' sub-sections include a 'Detector input' field with a grid of 12 buttons (1-12) and an 'in second' field with a spinner. Below each 'Logout' sub-section are 'Change of program X at second' and 'in second' fields with spinners. At the bottom right of the window are 'Delete', 'Cancel', and 'Ok' buttons.

There are separate input blocks for every program change (program 1 to 2 respectively program 3 to 4).

A program change on request is triggered by the detector inputs entered in the top list of the respective input block.

If a program change on request is triggered, the display shows **P** in the display of traffic light 1. After a cleardown of the program on request, this goes off.

Other entries (program change points) are also necessary, e.g. the second in the current program at which the program is left and the second in which the system should jump to the special program.

Cleardown is either at a fixed second in the special program or by means of a detector input entered in the bottom list in the input block. Program change points also have to be entered to change from the special program back to the basic program. The subsequent request function can be activated as an option.

If after cleardown of a program change on request a new request comes, the controller remains in the special program if the subsequent request function was activated. However, if the subsequent request function was not activated, the controller changes back to the basic program and then to the special program again.

Notes:

- After closing the mask, the system checks whether the data for program change on request are complete. Otherwise, corresponding messages appear.
- To use the program change on request function, traffic light 1 must have at least the software version N10:01 – 10:00.
- For online data transfer to the traffic light, an interface with version 5.04 can also be used.

- If the data are transferred to the interface or online to the handbox, interface version 6.00 and handbox version G0311 – 18:57 are needed.
- Corresponding messages appear if an attempt is made to use versions that are not compatible with each other.

If there is a version 6.00 program in the traffic light, in the interface or in the handbox with data for program change on request, the old version (5.04) cannot be used to transfer data to the traffic light.

To do so, the data have to be deleted in the corresponding controller. Switch traffic light 1 off and wait for at least 10 seconds before switching on again.

Please select the corresponding menu point in the interface or handbox.

Special function program change on request:

If an extension is active and a program change on request comes, the program changes immediately if the extension point and program change point are at the same second.

If the controller is standing at the waiting point (manual mode) and a program change on request comes, this is not changed until the manual button is pressed.

If the controller is running to a waiting point and a program change on request comes, the program change takes place when the corresponding program change point is at a waiting point.

If a program change on request is active for changing to flashing or blank, the controller runs to the AZP (OFF time) and then switches to flashing or blank as chosen. An active program change on request is then ended.

If a program change on request is active and manual mode is changed to ON or continuous red, the controller remains in the current program. An active program change on request is then not ended.

If a program change on request is active and the programs are changed using the handbox, these have priority. An active program change on request is then ended.

6.4.12 Program change extended on request / blanking

This mask is used to adjust the settings for an external, extended program change (detector, push button, etc.) or blanking.

The system changes to the required program or operating mode when a corresponding request is made.

Changing back is implemented by a detector input or by enabling in the program or cleardown after time.

The entries in this mask are adjusted to the selected basic setting. Boxes that are not needed are disabled and shown cross-hatched.

Note:

This function is only available for controller type EPB 12 / EPB 24 / EPB 48 from version 7.30.

6.4.12.1 Stipulate basic setting

Stipulate the required basic setting in the **basic setting** selection box. The choice is between:

- Standard function active
The standard function **Program change on request** is processed in the controller. The extended program change is not implemented by the controller.
- Program 1 to 6
Activates the **Program change extended on request** function. The standard function **Program change on request** is not implemented by the controller.
- Blanking / Flashing
Activates the **Blanking** function. The standard function **Program change on request** is not implemented by the controller.
- The value in the **min time basic setting** input box defines the minimum time that the controller remains in the basic setting until the function of the requested channel is implemented. The time counter starts as soon as the basic setting is reached.

Note:

On switching back to the basic setting **Standard function active**, the display shows the default settings for all entered values (but data are not deleted).

On choosing another basic setting, the display shows the values that were entered previously.

6.4.12.2 Request program change extended on request / blanking

In the top table, choose the detector inputs (a tick appears) for effecting a changeover in the active channel (program change, operating mode change).

Note:

If a channel function is active and blanking or program change extended is activated via one of the operating modes clock mode, radio clock or external, all channel functions must be cleared so that they are deactivated via the operating modes that are switched on. Changing the operating mode manually is an exception to this rule.

6.4.12.3 Channel allocation

Define the required function (program change, operating mode change) for the corresponding channel in the selection box.

6.4.12.4 Enable channel in seconds / program in seconds

Use the input boxes to specify when the respective change in the active channel / program is to be enabled.

If an enabling value is entered in seconds, when a request comes, the system takes the next additional GSP2 - 6 (intersection time plan editor) found from this second in the cycle.

If 0 is entered here, enabling is effective immediately.

When a request comes, before the program is changed the system checks whether a matching pair of GSP2-6 (intersection time plan editor) is present for the basic program and the target program.

If this is the case, the next additional GSP2 - 6 to be found is taken for the program change.

If no matching pair of additional GSP2 - 6 is present, then GSP1 is used for the program change.

If the **Back to basic setting** function is active, a change is always made from the program defined in the basic setting. **Enable channel in seconds** then always refers to this program. In this second, changing the program is enabled from the basic program to the requested target program.

If the **Back to basic setting** function is inactive, when corresponding requests come a program change can also take place directly between the programs without going back to the basic setting. **Enable channel in seconds** then always refers to the current program. In this second, changing the program is enabled from the current program to a requested program of another channel.

Notes:

- If **blanking** or **flashing** was chosen as basic setting, the input boxes for **Enable channel in seconds** have no function and are blocked.
- To change to the requested program, this also must have been enabled (Basic data - Program release).

6.4.12.5 Functioning of the channels

All channels are always processed in the sequence 1 to 8. If there is no request for a certain channel, the next channel is queried and processed if applicable. After working through all channels, the system starts again with the first one.

6.4.12.5.1 Functioning of extended program change on request

With the extended program change, the system always changes from program to program via the basic program or directly between programs, depending on the setting.

6.4.12.5.2 Functioning of blanking

When blanking (blanking / flashing) is the basic setting, when a request comes the switch-on program begins and then changes to the EZP of the program that is then valid. After clear-down, the controller runs on to the AZP and then via the switch-off program back to the basic setting. Depending on the setting, the system changes to another requested channel directly or via the basic setting.

6.4.12.6 Preemption

Depending on the channel, a preemption function can be activated. When a corresponding request comes for a channel, this is then given preemption treatment. In the **Continue with** selection box, you can select which channel the program should continue with after clear-down of a channel.

The choice is between the following possibilities:

- **Last channel**
After clear-down of the active channel, the channel that was last active is then processed.
- **Next channel**
After clear-down of the active channel, the channel that was requested is the next to be processed, always complying with the basic sequence channel 1 to 8.
- **Specific selection**
If you select one of the 8 channels to be processed next and there is no request for this channel, the system always works through the basic sequence.

Notes:

- If a preemption function is activated for several channels, the system always works through them in the sequence from 1 to 8.
- An active continuous red / preemption is not terminated by a channel request with priority. This channel request is then processed after the continuous red / preemption has been deregistered.

6.4.12.6. Priority lock

If this function is activated, after all channels with priority have been processed, the requested channels without priority are processed once. The requested channels without priority are processed once. Once these have been processed, the channels with priority are processed if requested. This function ensures that channels without priority are also processed.

Note:

If this function is switched off, only the channels with priority are processed.

6.4.12.7 Request options

When a channel request comes, various functions are available that can be chosen as options.

6.4.12.7.1 Detector presets

Depending on the setting, on reaching the target program the **detector preset** function is carried out once. 📄 6.4.2

6.4.12.7.2 Delete preset groups

Depending on the setting, on reaching the target program the **delete preset groups** function is carried out once. 📄 6.4.2

6.4.12.7.3 Trigger continuous red / preemption

Depending on the setting, here you can trigger continuous red / preemption for the requested target program so that it is active for a channel request.

No more green phase extensions (extensions) are then carried out until there is a program change.

On changing to the target program, continuous red / preemption is then active here.

Note:

- The function is not carried out if there are no data for continuous red / preemption in the target program.
- All clear-down functions and options entered in the continuous red / preemption mask for the target program are active.

6.4.12.7.4 Preemption contact control

This function stipulates the behaviour of the controller when this is in **Contact control** mode and other channels are requested.

Depending on the setting, the system waits until the contact control has ended (tick) – or the active channel is interrupted (no tick), and then works through the requested channels.

If several channels are requested permanently, these are worked through in succession.

If none of these channels is active any longer, the controller changes back to the **Contact control** mode and the function allocated there is carried out again.

Notes:

- If the function is activated and a request is made for a channel with contact control, these are processed with priority. Active channels with a priority function are cancelled.
- An active continuous red / pre-emption is not terminated by the contact control with priority.
This channel request is saved and then processed.

6.4.12.7.5 Premature clear-down

Depending on the setting, here you can choose whether premature channel clear-down is possible. If this option is switched on, the defined detector inputs for the clear-down are already evaluated before the system changes to the target program of the requested channel.

In the default setting, evaluation only takes place when the target program of the requested channel is active.

Note:

Early logout is only carried out up to the release second of a requested channel.

If a channel is already active (release received), premature deregistration is no longer performed for this channel.

In this case, the active channel can only be deregistered using one of the defined deregistration functions.

6.4.12.7.6 Forced trigger

Depending on the setting, here you can choose whether a forced channel request should be triggered. When this function is active, an automatic request for a channel is triggered within a stipulated period if this has no longer been requested for a certain time (similar to the forced cycle). The choice of time is taken from the data in the forced cycle mask for the respective program.

The time counter always starts immediately after cleardown of an active channel. Each channel has its own counter.

Note:

This function is only carried out if a program has been adjusted as channel function. This function does not apply to channels that trigger a change in operating mode.

6.4.12.8 Cleardown for program change extended to request / blanking

As for the request function, in the bottom table choose the detector inputs that release the change back to the currently active channel.

The change back can also be released at any second in the respective program. The entry is made separately for every program in the seconds box for the respective program.

Changing back to the basic setting takes place with the next GSP2 – 6 (intersection time plan editor) to be found with blanking via the AZP.

If the additional GSP2 - 6 (intersection time plan editor) are not supplied, then GSP1 is used for the program change.

Note:

If no cleardown is entered, the system does not change back to the basic setting.

In a channel, a detector input can only be selected for request or for cleardown (locked against each other).

The contact control function is not carried out in this case. ☞ 6.4.12.4

6.4.12.8.1 Cleardown for program change extended on request / blanking in seconds

If you want cleardown for a program change extended on request / blanking in a second in the cycle, please enter the required time in the corresponding input boxes.

Note:

The function **Cleardown program in seconds** is not carried out if **Continuous red** is adjusted as channel function.

6.4.12.8.2 Cleardown for program change extended on request / blanking after time

If you want cleardown for a program change on request / blanking after time, please enter the required time in the corresponding input boxes.

The time for automatic cleardown begins as soon as the target function is reached.

6.4.12.9 Request options

As with a channel request, here too various functions are available that can be chosen as options.

6.4.12.9.1 Back to basic setting

If this option is activated, the controller always goes back to the basic setting after a clear-down. If a further request has been received, the system starts changing to a new target function from the basic setting. If no tick has been set, changing to the target function takes place immediately from the current function (program change via GSP or change in operating mode).
If this function is active, the controller remains in a cleared down channel if a new request has been triggered for this channel.

6.4.12.9.2 Detector presets

Depending on the setting, on reaching the target program the **detector preset** function is carried out once. ☞ 6.4.2

6.4.12.9.3 Delete preset groups

Depending on the setting, on reaching the target program the **delete preset groups** function is carried out once. ☞ 6.4.2

6.4.12.10 Program change extended on request / blanking by contact control

For contact control to be carried out, no clear-down function (detector inputs, clear-down in second, clear-down after time) may be present in the channel to which the system is to change.

How it works:

As soon as one of the defined inputs triggering the program change extended on request / blanking is busy, the controller changes to the previously stipulated channel. The controller then remains in this channel until there is no longer any signal at these inputs.

6.4.12.11 Display notifications for program change extended on request / blanking

The notifications on the first display side in the controller change when blanking is activated. **Blanking** is shown as program in the program display.

The text after the mode display changes depending on which program / blanking mode was requested by a channel request:

- Cont red blank = continuous red functions requested via blanking
- Manual - blank = program 1 to 6 requested via blanking
- Clock - blank = clock mode requested via blanking
- Rad clock – blank = radio clock mode requested via blanking
- External - blank = external programs requested via blanking
- Emerg. - blank = emergency program requested via blanking

If **prog.ch** appears instead of **blank**, the current program/mode has been requested by a channel request in the extended program change.

Note:

If there is no active channel request for the extended program change / blanking, then the default displays appear again.

6.4.13 End extension prematurely

This mask can be used to end an active extension via individual detector inputs while the system is running. The setting can be adjusted separately for every program.

Note:

This function is only supported from CPU version 6.20. The full scope of the entry mask is supported from version 6.30.

The entries are adjusted to the selected controller type / version. Boxes that are not needed are disabled and shown cross-hatched.

The number of visible programs changes according to the program release.  **6.1.7**

6.4.13.1 Activate end extension prematurely

Use **Activate by detector input** for adjust the detector inputs to activate the end extension prematurely function.

Select the groups where an extension is to be ended in **End extension for group**. On receiving input from an assigned detector, the selected groups switch only to minimum release time or an active extension is ended.

When a value is entered for **Stopping point in seconds** (0 = no function), the running program stops in this cycle second until the end extension prematurely function is switched off again.

If the system is standing at a stopping point and the end extension prematurely function is switched off, the program remains at the stopping point for the value entered in **delay time**. Every stopping point can be allocated its own delay time. The stopping points do not have to be entered in sequence. When the function is active, the program stops at the next stopping point until cleardown.

Notes:

- When the manual mode is switched on, the end extension prematurely function ends immediately because manual mode takes priority.
- If manual mode is active and a request comes for the end extension prematurely function, this is ignored and also not saved.
- From CPU version 6.91, no more progressive signalling continue times are carried out when this function is triggered.

6.4.13.2 Deactivate end extension prematurely

Use **Deactivate function** for adjusting the detector inputs to deactivate the **End extension prematurely** function.

As an alternative, the function can also be switched off automatically after an adjustable time.

The time is entered in **Automatically deactivate after xx seconds**.

Depending on the setting, the time counter for automatic deactivation starts immediately (when triggered) or when the program is at a stopping point.

If there is a program change in this status and the value for **Automatically deactivate after xx seconds** is higher in the new program, this value is taken as maximum value for the clear-down counter.

Note:

In version 6.20 programs, the start of the counter is preset to when triggered, as the function is fixed in that way for this software version.

Nor does this version support several stopping points with their own delay times!

6.4.13.3 Deactivate end extension prematurely at cycle second

As an alternative, the **End extension prematurely** function can be ended at a fixed second in the respective program.

Notes:

- It is possible to combine the various options for switching off the **End extension prematurely** function.
- As soon as the **End extension prematurely** function has been deactivated, the extension function is enabled again for all groups.
- If deactivating the **End extension prematurely** function is ended before an entered stopping point, this and the following delay time are not carried out!
- If no function to deactivate the **End extension prematurely** function is selected, this is only deactivated after a reset or if the controller is rebooted.
From CPU version 7.00, in this case the contact control function is carried out.

☞ 6.4.13.6

6.4.13.4 Special functions: cancel extension prematurely

If **End extension prematurely** is active and there is a program change, this function is automatically ended if there are no corresponding data in the new program.

If no signal groups whose extension should be ended have been selected in the new program, the **End extension prematurely** function is then ended in this function.

If the new program has corresponding data, this function is not deactivated; the counter values may be possibly be updated.

If there is a program change, the counter values are taken from the new active program. If a counter is already running and the new value is higher, the difference is added to the counter.

If the new value is smaller, the counter is deemed to have expired and the respective function is ended immediately.

6.4.13.5 Counter start at stopping point / start when triggered

If there is a program change and the counter start function changes, the controller reacts as follows:

Variation 1 (current program **Start when triggered**, new program **Start at stopping point**)

If the counter is already running and **Start at stopping point** is adjusted in the new program, the counter is stopped, set to the new value and restarted at the stopping point.

If the controller is standing at a stopping point and the counter is already running, the difference is added to the counter if the new value is higher. If the new value is smaller, the counter is deemed to have expired and the delay time is ended.

Variation 2 (current program **Start at stopping point**, new program **Start when triggered**)

If there is a program change where the start function is changed from **Start at stopping point** to **Start when triggered**, the counter begins immediately with the current value when the program change has been carried out.

6.4.13.6 End extension prematurely with contact control

From CPU version 7.00, the end extension prematurely function can be carried out with contact control. For contact control to be carried out, no clear-down function (detector inputs, clear-down in second, deactivate automatically after time) may be present in the respective program.

How it works:

As soon as one of the defined inputs that trigger the end extension prematurely function is in use, this function only ends when there is no longer any signal at these inputs.

6.4.13.7 End extension prematurely displays

Various displays appear when the function is activated:

- (ET canc.) = Cancel extension time function is active
- SP1 N:000 = Controller standing at stopping point (SP1 to 8), delay time duration
- End: 000 = Time until automatic deactivation of the function (time-out counter)

Note:

If several special functions are active, the corresponding displays appear at single-second intervals.

6.4.14 Continuous red / preemption

This mask can be used to trigger continuous red / preemption while the system is running. The setting can be adjusted separately for every program. The following functions are possible:

- **Continuous red**
The controller switches to continuous red as soon as possible; after clear-down after a specified second it then continues to run in the program. 🗨 6.4.14.2
- **Jump to second**
The controller switches to continuous red as soon as possible and then jumps to a specified second in the program where it remains standing at a specified second possibly until clear-down. 🗨 6.4.14.3

Continuous red/priority circuit: Program 1 / group 1

Program 1

Activate function

Activate by detector input

No.	1	2	3	4	5	6	7	8	9	10	11	12	13	14	15	16	17	18	19	20	21	22	23	24
	<input checked="" type="checkbox"/>	<input type="checkbox"/>	<input type="checkbox"/>	<input type="checkbox"/>	<input type="checkbox"/>	<input type="checkbox"/>	<input type="checkbox"/>	<input type="checkbox"/>	<input type="checkbox"/>	<input type="checkbox"/>	<input type="checkbox"/>	<input type="checkbox"/>	<input type="checkbox"/>	<input type="checkbox"/>	<input type="checkbox"/>	<input type="checkbox"/>	<input type="checkbox"/>	<input type="checkbox"/>	<input type="checkbox"/>	<input type="checkbox"/>	<input type="checkbox"/>	<input type="checkbox"/>	<input type="checkbox"/>	<input type="checkbox"/>

Disable function

Disable by detector input

No.	1	2	3	4	5	6	7	8	9	10	11	12	13	14	15	16	17	18	19	20	21	22	23	24
	<input type="checkbox"/>	<input type="checkbox"/>	<input type="checkbox"/>	<input type="checkbox"/>	<input type="checkbox"/>	<input type="checkbox"/>	<input type="checkbox"/>	<input type="checkbox"/>	<input type="checkbox"/>	<input type="checkbox"/>	<input type="checkbox"/>	<input type="checkbox"/>	<input type="checkbox"/>	<input type="checkbox"/>	<input type="checkbox"/>	<input type="checkbox"/>	<input type="checkbox"/>	<input type="checkbox"/>	<input type="checkbox"/>	<input type="checkbox"/>	<input type="checkbox"/>	<input type="checkbox"/>	<input type="checkbox"/>	<input type="checkbox"/>

Options at the end of the function

Proceed with detector presets

Delete preset requirements

Request lock

0 seconds

Function

Continuous red - change in 0 seconds

Change in 0 seconds

Stopping point in 0 seconds

Priority circuit

Automatic log-off

Disable automatically after 0 seconds

Start counter in continuous red / stopping point

Start counter at resolution

Delete Cancel OK

Notes:

- This function is only available for controller type EPB 12 / EPB 24 / EPB 48 from version 6.80.
- If manual mode is active, **Continuous red / preemption** ends immediately because manual mode takes priority
- If manual mode is active and a request comes for **Continuous red / preemption**, this is ignored and also not saved.
- No program change is carried out when **Continuous red / preemption** is active. If a program change is present, it is carried out only after the end of **Continuous red / preemption**.
- No more progressive signalling continue times are carried out when this function is triggered.

6.4.14.1 Activate continuous red / preemption

Use **Activate by detector input** for adjusting the detector inputs to activate **Continuous red / preemption**. If a detector input is selected that is already use for clear-down, the selection is removed when deactivating the function.

Note:

If a group in the current program has continuous green, **continuous red / preemption** is not carried out and the request is rejected.

6.4.14.2 Continuous red - continue in second

When this function is selected, the controller switches to continuous red as quickly as possible. Groups at green end their green phase at after their release time phase (referred to the minimum release time in the intersection time plan).

As soon as the controller has reached continuous red status, it remains in the continuous red status until the function is deactivated by a detector input or by the timeout.

If the contact control is active, the function only ends when the corresponding conditions are fulfilled.

6.4.14.7

Note:

On reaching the continuous red status, the time counter remains at second 255 as a visual check.

6.4.14.3 Jump to second

When this function is selected, the controller switches to continuous red as quickly as possible. Groups at green end their green phase at after their minimum release time (referred to the minimum release time in the intersection time plan).

On reaching the continuous red status, there are various options for continuing the program:

- **Jump to second**
Taking account of the interim times, the controller jumps at the second entered in the input box **Jump to second** and continues the program from this second. The function then no longer has to be deactivated. If **0** is entered for **Jump to second**, then the jump is carried out at the cycle second.
- **Stopping point**
Taking account of the interim times, the controller jumps in the second entered in the input box **Jump in second**. The controller then stops in the program second entered in the input box **Stopping point in**. The controller stops here until the function is deactivated by a detector input or the timeout.
If there is no stopping point, the controller continues from the program second entered in **Jump in second**. The function then no longer has to be deactivated.

Note:

If both functions are combined, the controller remains standing in the entered stopping point as soon as the jump has been carried out.

6.4.14.4 Special function for jump to second with stopping point

When continuous red / preemption is triggered, the system checks whether the current cycle second is the range of the values entered for **Jump to second** and **Stopping point**.

If this is the case, the controller stops in the stopping point as soon as it has been reached (unless already in this second). The controller then remains standing in the stopping point until clear-down (input or timeout).

If the current cycle second is outside this range or if there is no stopping point, all groups cancel their release time after their minimum release time phase. Taking account of the interim times, the controller then jumps to the second entered in **Jump to second**. The program continues from this second and remains standing at the stopping point if one is present, until clear-down.

Note:

This special function is only supported from version 6.81 (EPB 12 / EPB 24 / EPB 48).

In version 6.80 (EPB 12 / EPB 24 / EPB 48), all groups cancel their green phase after their minimum release time. Taking account of the interim times, the controller then jumps to the specified second and remains standing at the stopping point if one is present, until clear-down.

6.4.14.5 Preemption

This additional option can be used to control the behaviour on triggering **Continuous red / preemption**.

- **Preemption active**
If **End extension prematurely** is active, this is ended immediately as soon as there is a request for **Continuous red / preemption**.
Continuous red / preemption is then carried out immediately.
- **Preemption inactive**
If **End extension prematurely** is active and there is a request for **Continuous red / preemption**, this is given secondary priority.
Continuous red / preemption is not carried out until **End extension prematurely** has finished.

6.4.14.6 Deactivate continuous red / preemption

Use **Deactivate function** for adjusting the detector inputs to switch **Continuous red / preemption** off again.

As an alternative, the function can also be switched off automatically after an adjustable time. The time is entered in **Automatically deactivate after xx seconds**. Depending on the setting, the time counter for automatic deactivation starts immediately (when triggered) or when the program is at the stopping point or in continuous red.

Notes:

- It is not possible to select a detector input that is already being used for request.
- If no function is selected to deactivate continuous red / pre-emption, this is only deactivated after a reset or if the controller is rebooted.
From CPU version 7.00, in this case the contact control function is carried out.
☞ **6.4.14.7**

6.4.14.7 Continuous red / preemption with contact control

From CPU version 7.00, continuous red / preemption can be carried out with contact control. For contact control to be carried out, no clear-down function (detector inputs, deactivate automatically after time) may be present in the respective program.

How it works:

As soon as one of the defined inputs that trigger continuous red / preemption is triggered, this function only ends when there is no longer any signal at these inputs.

Note:

There must not be any values in the **Automatic clear-down** input box for the timeout. As soon as a value is present here, the timeout counter starts when the function is activated, depending on the setting. Contact control is not carried out in this case.

6.4.14.8 Continuous red / preemption options

6.4.14.8.1 Proceed with detector presets

On selecting this function, after **Continuous red / preemption** is finished, the **Automatic detector presets** function is carried out. ☞ 6.4.2

6.4.14.8.2 Delete request presets

On selecting this function, after **Continuous red / preemption** is finished, the **Delete request presets** is function carried out once. ☞ 6.4.3

6.4.14.9 Request block

Here you can activate a request block (1 - 999 seconds) which is deactivated when set to 0. If this function is activated, a renewed request for continuous red / preemption is blocked for this time and cannot be processed again until this time has expired. The request block time begins immediately after clear-down of continuous red / preemption.

Note:

This function is only supported from version 7.20 (EPB 12 / EPB 24 / EPB 48).

6.4.14.10 Continuous red / preemption displays

Various displays appear when the function is activated:

- (continuous red) **Continuous red / preemption** is active
- HP controller is standing at the stopping point (SP)
- End: 000 Time until automatic deactivation of the function (timeout counter)

Note:

If several special functions are active, the corresponding displays appear at single-second intervals.

6.4.15 Manage outputs

In this menu point, individual lamp outputs of the signal groups can be moved to another group. This function is only available for controller type EPB 12 / EPB 24 / EPB 48.

On selecting this function, a password query appears first.

The required outputs can be moved when the password is entered correctly (available on request). An error message appears if the password is entered incorrectly.

If an incorrect password is entered, the input window only opens in viewer mode: no data can be entered or changed.

Outputs that have already been moved are listed.

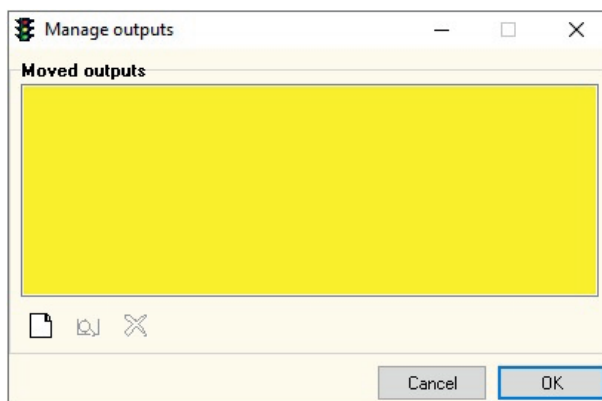

There are three buttons on the left: new entry, edit marked entry and delete marked entry. The edit and delete buttons are only enabled if there are entries in the list.

Note:

The buttons are generally disabled when an incorrect password is entered.

6.4.15.1 Move outputs

Selecting the left button **New entry** opens the following entry mask:

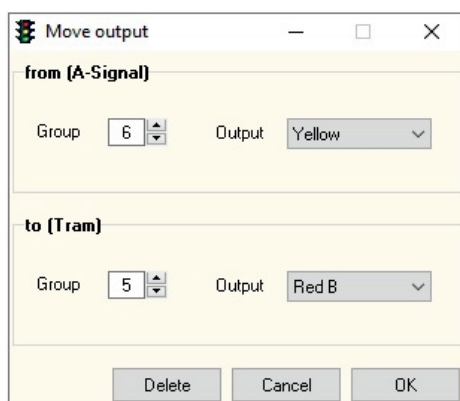

Select the required group at the top after **From** and indicate the lamp output to be moved at **Output**.

Enter the group and lamp output to which the signal should be moved at the bottom **To**.

On selecting a group, the group name of this group automatically appears in brackets after **From** or **To**. Some input boxes are disabled if no data have been entered.

On selecting a group after **From**, the corresponding **Output** box is enabled.

As soon as an output has been selected here, the target group can be entered after **To**.

Once this has been selected, the corresponding target output can be defined.

The following target outputs can be selected:

Red A - the selected lamp output is triggered at output red A of the target group

- Red B - the selected lamp output is triggered at output red B of the target group
- Yellow - the selected lamp output is triggered at the yellow output of the target group
- Green - the selected lamp output is triggered at the green output of the target group
- Output off - the selected lamp output remains off, selection of the target group is hidden

Close with **OK** to save the data in the list of the moved outputs

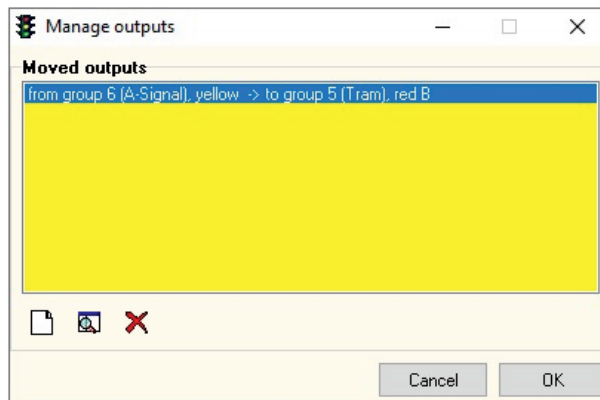

Note:

- The controller continues to trigger moved outputs until they are cancelled again. Moved outputs apply to all active power cards of the affected group.
- If **Output off** is selected for an output, lamp monitoring must be disabled for this group if no lamp is connected to this output.
- If outputs have been moved, lamp or status monitoring at the original groups must be disabled if no lamps are connected here.
- If lamp or status monitoring is necessary for moved groups, this must be adjusted on the power cards triggering the signal.
- In view of the fact that among others, green/green monitoring constantly checks the green outputs of the power cards, it is important to ensure that moving the outputs does not generate any hostile green.
- If lamp or status errors are reported from moved groups, the physical output (the power card triggering the error) is always shown as the cause.

Example:

The yellow output of group 6 was moved to red B of group 5. If there is a lamp defect in group 5 red B, this is reported as the cause although this is in fact the yellow of group 6.

6.4.15.2 Editing manage outputs

To edit an entry, it must be marked in the list.

To open the input window for editing the data, press the middle button or double click the left mouse button on the marked entry.

The current values are preset. If these are changed and the window closed with **OK**, the list of moved outputs is updated accordingly.

6.4.15.3 Deleting manage outputs

To delete an entry, it must be marked in the list.

If you press the right-hand button, a query appears to confirm whether the marked entry should be deleted.

Depending on the confirmation, the window is closed and the list of moved outputs is updated accordingly.

6.4.15.4 Example move outputs

In the following example, the yellow output from group 6 was moved to the red B output of group 5.

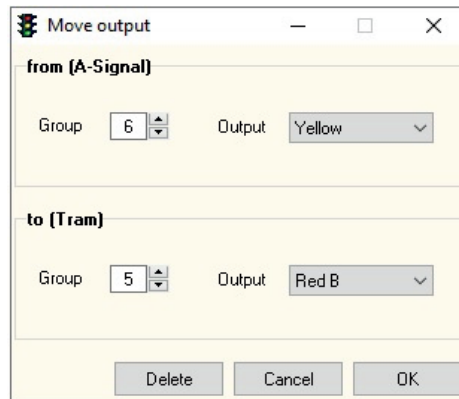

If the program actuates yellow of group 6, the output appears at the signal head connected to group 5 red B.

6.4.16 Group mapping list EPB 12

This entry mask is only available for controller type EPB 12. It is used for mapping/assigning the signal groups to the respective outputs of the power cards (standard default is 1:1).

Every active group must be assigned a power card output.

This mask is only visible if controller type EPB 12 Master + Slave is activated. It is not visible if controller type EPB 12 Master is selected.

From Ampeltools version 1.20, the group name appears in this mask.

Exceptions:

- Switching controller type from EPB 12 Master and Slave to EPB 12 Master: mapping is not 1:1.
- A program has been loaded with changed mapping. In this case, a corresponding message appears.

Mapping master				Mapping slave			
Slot 1		Slot 2		Slot 1		Slot 2	
Output	Group	Output	Group	Output	Group	Output	Group
1	1 (K1)	1	3 (K2)	1	9 (F25/26)	1	11 (F29/30)
2	2 (K1L)	2	4 (K2L)	2	10 (F27/28)	2	12 (F31/32)
Slot 3		Slot 4					
Output	Group	Output	Group				
1	5 (K3)	1	7 (F21/22)				
2	6 (K4)	2	8 (F23/24)				

If only the master controller is used (8 groups), standard mapping does not need to be changed as all signal group connections are in the controller.

When using the slave control as well, it can make sense to change the mapping. For example, if group 5 (intersection time plan sequence) were at the site of the slave, group 5 would be assigned a slave output.

The following entries are possible: 1 to 12 and 0 (output not in use).

Closing the mask with OK results in a check of the data (only for the active groups).

A corresponding warning appears if a faulty entry is found.

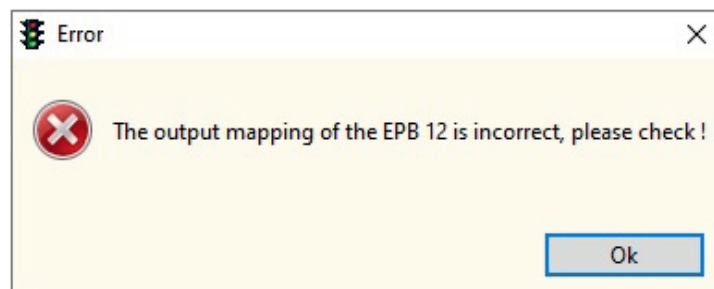

Note:

A message appears if a program is transferred to the controller with a different group mapping list from the current program in the controller.

The message lists all differences. Data transfer then begins, depending on how the list is confirmed.

6.5 Parameter lists

This function can be used to manage up to 24 parameter lists each for extension time 1 + 2. The parameter lists can be combined with 6 possible day programs. In each case, different parameters (max. extension times) are loaded for the current day program. The parameter lists can be activated either with the manual program selection or with a switching time of the weekly automatic radio clock. Up to 150 program variants can be switched with this function.

Note:

This function is only available for controller type EPB 12 / EPB 24 / EPB 48 from version 7.10

6.5.1 Parameter lists names

This mask is used to give every parameter list a name. The name then appears in the heading of the parameter lists and when selecting the day's schedules (weekly automatic radio clock).

The screenshot shows a window titled "Parameter list names" with a standard Windows-style title bar (minimize, maximize, close buttons). The window contains 24 text input fields, arranged in two columns of 12. Each field is preceded by a label: "Parameter list 1", "Parameter list 2", ..., "Parameter list 12" in the left column, and "Parameter list 13", "Parameter list 14", ..., "Parameter list 24" in the right column. The first input field is selected with a blue border. At the bottom of the window, there are three buttons: "Clear", "Cancel", and "Ok".

Note:

This function is only available for controller type EPB 12 / EPB 24 / EPB 48 from version 7.10

6.5.2 Extension time 1

This mask is used to manage the maximum extension times of extension point 1. The maximum input is 240 seconds.

As soon as a parameter list is active, these extension times are used for the corresponding groups in the currently active day program.

Groups with a zero in the parameter list still use the extension times from the day program that is active in each case.

Parameter list extension time 1, group: 1, Plan 15

No./Grp.	1	2	3	4	5	6	7	8	9	10	11	12	13	14	15	16	17	18	19	20	21	22	23	24
1	0	0	0	0	0	0	0	0	0	0	0	0	0	0	0	0	0	0	0	0	0	0	0	0
2	0	0	0	0	0	0	0	0	0	0	0	0	0	0	0	0	0	0	0	0	0	0	0	0
3	0	0	0	0	0	0	0	0	0	0	0	0	0	0	0	0	0	0	0	0	0	0	0	0
4	0	0	0	0	0	0	0	0	0	0	0	0	0	0	0	0	0	0	0	0	0	0	0	0
5	0	0	0	0	0	0	0	0	0	0	0	0	0	0	0	0	0	0	0	0	0	0	0	0
6	0	0	0	0	0	0	0	0	0	0	0	0	0	0	0	0	0	0	0	0	0	0	0	0
7	0	0	0	0	0	0	0	0	0	0	0	0	0	0	0	0	0	0	0	0	0	0	0	0
8	0	0	0	0	0	0	0	0	0	0	0	0	0	0	0	0	0	0	0	0	0	0	0	0
9	0	0	0	0	0	0	0	0	0	0	0	0	0	0	0	0	0	0	0	0	0	0	0	0
10	0	0	0	0	0	0	0	0	0	0	0	0	0	0	0	0	0	0	0	0	0	0	0	0
11	0	0	0	0	0	0	0	0	0	0	0	0	0	0	0	0	0	0	0	0	0	0	0	0
12	0	0	0	0	0	0	0	0	0	0	0	0	0	0	0	0	0	0	0	0	0	0	0	0
13	0	0	0	0	0	0	0	0	0	0	0	0	0	0	0	0	0	0	0	0	0	0	0	0
14	0	0	0	0	0	0	0	0	0	0	0	0	0	0	0	0	0	0	0	0	0	0	0	0
15	0	0	0	0	0	0	0	0	0	0	0	0	0	0	0	0	0	0	0	0	0	0	0	0
16	0	0	0	0	0	0	0	0	0	0	0	0	0	0	0	0	0	0	0	0	0	0	0	0
17	0	0	0	0	0	0	0	0	0	0	0	0	0	0	0	0	0	0	0	0	0	0	0	0
18	0	0	0	0	0	0	0	0	0	0	0	0	0	0	0	0	0	0	0	0	0	0	0	0
19	0	0	0	0	0	0	0	0	0	0	0	0	0	0	0	0	0	0	0	0	0	0	0	0
20	0	0	0	0	0	0	0	0	0	0	0	0	0	0	0	0	0	0	0	0	0	0	0	0
21	0	0	0	0	0	0	0	0	0	0	0	0	0	0	0	0	0	0	0	0	0	0	0	0
22	0	0	0	0	0	0	0	0	0	0	0	0	0	0	0	0	0	0	0	0	0	0	0	0
23	0	0	0	0	0	0	0	0	0	0	0	0	0	0	0	0	0	0	0	0	0	0	0	0
24	0	0	0	0	0	0	0	0	0	0	0	0	0	0	0	0	0	0	0	0	0	0	0	0

0

Note:

Parameter lists with extension times are always saved at the start of an extension point. If the program is currently in an extension point, the remaining extension time of the current program is completed.

This function is only available for controller type EPB 12 / EPB 24 / EPB 48 from version 7.10

6.5.3 Extension time 2

This mask is used to manage the maximum extension times of extension point 2. The maximum input is 240 seconds.

As soon as a parameter list is active, these extension times are used for the corresponding groups in the currently active day program.

Groups with a zero in the parameter list still use the extension times from the day program that is active in each case.

Parameter list extension time 2, group: 1, Plan 15

No./Grp.	1	2	3	4	5	6	7	8	9	10	11	12	13	14	15	16	17	18	19	20	21	22	23	24
1	0	0	0	0	0	0	0	0	0	0	0	0	0	0	0	0	0	0	0	0	0	0	0	0
2	0	0	0	0	0	0	0	0	0	0	0	0	0	0	0	0	0	0	0	0	0	0	0	0
3	0	0	0	0	0	0	0	0	0	0	0	0	0	0	0	0	0	0	0	0	0	0	0	0
4	0	0	0	0	0	0	0	0	0	0	0	0	0	0	0	0	0	0	0	0	0	0	0	0
5	0	0	0	0	0	0	0	0	0	0	0	0	0	0	0	0	0	0	0	0	0	0	0	0
6	0	0	0	0	0	0	0	0	0	0	0	0	0	0	0	0	0	0	0	0	0	0	0	0
7	0	0	0	0	0	0	0	0	0	0	0	0	0	0	0	0	0	0	0	0	0	0	0	0
8	0	0	0	0	0	0	0	0	0	0	0	0	0	0	0	0	0	0	0	0	0	0	0	0
9	0	0	0	0	0	0	0	0	0	0	0	0	0	0	0	0	0	0	0	0	0	0	0	0
10	0	0	0	0	0	0	0	0	0	0	0	0	0	0	0	0	0	0	0	0	0	0	0	0
11	0	0	0	0	0	0	0	0	0	0	0	0	0	0	0	0	0	0	0	0	0	0	0	0
12	0	0	0	0	0	0	0	0	0	0	0	0	0	0	0	0	0	0	0	0	0	0	0	0
13	0	0	0	0	0	0	0	0	0	0	0	0	0	0	0	0	0	0	0	0	0	0	0	0
14	0	0	0	0	0	0	0	0	0	0	0	0	0	0	0	0	0	0	0	0	0	0	0	0
15	0	0	0	0	0	0	0	0	0	0	0	0	0	0	0	0	0	0	0	0	0	0	0	0
16	0	0	0	0	0	0	0	0	0	0	0	0	0	0	0	0	0	0	0	0	0	0	0	0
17	0	0	0	0	0	0	0	0	0	0	0	0	0	0	0	0	0	0	0	0	0	0	0	0
18	0	0	0	0	0	0	0	0	0	0	0	0	0	0	0	0	0	0	0	0	0	0	0	0
19	0	0	0	0	0	0	0	0	0	0	0	0	0	0	0	0	0	0	0	0	0	0	0	0
20	0	0	0	0	0	0	0	0	0	0	0	0	0	0	0	0	0	0	0	0	0	0	0	0
21	0	0	0	0	0	0	0	0	0	0	0	0	0	0	0	0	0	0	0	0	0	0	0	0
22	0	0	0	0	0	0	0	0	0	0	0	0	0	0	0	0	0	0	0	0	0	0	0	0
23	0	0	0	0	0	0	0	0	0	0	0	0	0	0	0	0	0	0	0	0	0	0	0	0
24	0	0	0	0	0	0	0	0	0	0	0	0	0	0	0	0	0	0	0	0	0	0	0	0

0

Note:

Parameter lists with extension times are always saved at the start of an extension point. If the program is currently in an extension point, the remaining extension time of the current program is completed.

This function is only available for controller type EPB 12 / EPB 24 / EPB 48 from version 7.10

6.5.4 Options parameter lists

In this mask, you can stipulate when a parameter list ends, when another program becomes active, when the operating mode changes or when a special mask becomes active.

Deactivate program lists on selecting program / changing mode			
	Manual mode	External mode	Emergency program
Program 1	End active parameter list	End active parameter list	End active parameter list
Program 2	End active parameter list	End active parameter list	<input checked="" type="checkbox"/> Clock mode
Program 3	End active parameter list	End active parameter list	<input checked="" type="checkbox"/> Flashing (keyboard)
Program 4	End active parameter list	End active parameter list	
Program 5	End active parameter list	End active parameter list	
Program 6	End active parameter list	End active parameter list	
	<input checked="" type="checkbox"/> blank	<input checked="" type="checkbox"/> flashing	<input checked="" type="checkbox"/> blank
	<input checked="" type="checkbox"/> continuous red	<input checked="" type="checkbox"/> continuous red	<input checked="" type="checkbox"/> flashing

Behaviour for active special masks				
	Program change on request	Cancel extension time	Continuous red/preemption	Blanking
Program 1	No action	No action	No action	No action
Program 2	No action	No action	No action	No action
Program 3	No action	No action	No action	No action
Program 4	No action	No action	No action	No action
Program 5	No action	No action	No action	No action
Program 6	No action	No action	No action	No action

6.5.4.1 Deactivate parameter lists

Various options for the parameter lists are available, depending on operating mode or active program.

6.5.4.1.1 Select program manually / externally

On selecting a program in one of these modes, you can choose the behaviour of the parameter lists here. The following possibilities can be selected:

- No action
The current parameter list remains effective.
- Deactivate active parameter list
The extension times of the now active program are executed.
- Open other parameter list
Choose the required parameter list in the selection box, it is then active.
On ending the corresponding special mask, the now valid parameter list that was selected manually or stipulated by the weekly automatic function is now active again.

On selecting blanking, flashing or continuous red programs, you choose select whether to end an active parameter list or not.

Note:

A parameter list allocated to a program is not loaded until the system changes to the currently selected program.

6.5.4.1.2 Change operating mode

Depending on the active operating mode, various options are available for how the parameter lists behave.

6.5.4.1.2.1 Clock mode / flashing (keyboard)

If clock mode or flashing is selected on the keyboard, you can choose whether to end an active parameter list or not.

Notes:

- If the switching times of the weekly automatic radio clock are used in clock mode, the parameter lists are not deactivated, regardless of the setting. The switching commands of the weekly automatic radio clock then still apply.
- Select **"Flashing"** on the keyboard to deactivate an active parameter list, if enabled.
If the controller is restarted by pressing **"Start"**, no parameter list is loaded. A parameter list is not loaded until the operating mode changes, the system changes to another program or a parameter list is selected manually.

6.5.4.1.2.2 Emergency program

Once the emergency program is activated (selected manually or automatically), you can choose the behaviour of the parameter lists here. The following possibilities can be selected:

- No action
The current parameter list remains effective.
- Deactivate active parameter list
The extension times of the now active program are executed.
- Open other parameter list
Choose the required parameter list in the selection box, it is then active.
On ending the corresponding special mask, the now valid parameter list that was selected manually or stipulated by the weekly automatic function is now active again.

Note:

If the emergency program is ended again, the saved parameter list is loaded according to the currently valid program.

6.5.4.2 Behaviour for active special masks

Once a special mask is active, you can choose the behaviour of the parameter lists here. The following possibilities can be selected:

- No action
The current parameter list remains effective.
- Deactivate active parameter list
The extension times of the now active program are executed.
- Open other parameter list
Choose the required parameter list in the selection box, it is then active.
On ending the corresponding special mask, the now valid parameter list that was selected manually or stipulated by the weekly automatic function is now active again.

Note:

If several special masks are active at the same time, the system loads the parameter list of the special mask with the highest priority. The following order of priority applies:

- Continuous red / preemption (top priority)
- Cancel extension time
- Program change on request
- If no more special masks are active, the saved parameter list is loaded according to the currently valid program.

6.6 Number of signal heads

This window is used to adjust the number of signal heads per group for the controller type MPB 4xxx.

The entries are adjusted to the selected controller type (radio / cable). Boxes that are not needed are disabled and shown cross-hatched.

Group :	1	2	3	4	5	6	7	8	9	10	11	12
	0	0	0	0								

0 [spin button] [Delete] [Cancel] [Ok]

Note:

The minimum entry is two signal heads. If the window is closed with **OK** and fewer than two signal heads have been entered, a corresponding message appears. The window cannot be closed with **OK** if fewer than two signal heads have been entered.

6.7 Signal safeguarding

This menu is used for entering the monitoring details (signal safeguarding). The entry masks differ according to the controller type.

Details for lamp monitoring (defects) and status monitoring are entered here (depending on the controller type).

Interim time monitoring and the locking matrix are produced automatically on the basis of the existing interim time matrix.

6.7.1 Mixed mode signal heads / blind module

Mixed operation of tactile signal heads (acoustic module, vibrating push-button) is **not** possible in LED mode because the power consumption corresponds to approximately one LED module.

They need to be supplied by their own signal groups.

Combinations with conventional lamp technology are possible. Lamp defects are detected perfectly in this case.

Note:

When tactile signal heads are operated as their own group, lamp monitoring must be disabled for this group.

6.7.2 Signal safeguarding EPB 24 / EPB 48

This window is used to define the number of power cards per group and to adjust the monitoring details.

This function is only needed for controller type EPB 24 / EPB 48. The entry mask is disabled for other controller types.

The active groups are marked with a depressed button.

The current group / card and the group name appear in the header.

Signal safeguarding, group 1, index card 1 (K1.1/ K1.2)

Signal safeguarding

Group: 1 2 3 4 5 6 7 8 9 10 11 12 13 14 15 16 17 18 19 20 21 22 23 24

Power card
Power cards count 1 for group 1

Designation
K1.1/K1.2

Power cards count
8

Index card 1

Monitored lamp outputs
 Red A Red B Yellow Green

Status monitoring
 Red A Red B Yellow Green

Error message for red lamp
 Red A defective
 Red A and red B defective

Note:
Status monitoring must be disabled for all lamp outputs where no lamp or no LED module is connected

Controller error off

For red error
Card 1

For yellow error
Card 1

For green error
Card 1

Copy Delete Cancel Ok

Note:

The following defaults are preset for each group:

- Number of power cards = 1, monitored lamp output Rot A
- Status monitoring activated for all outputs.
- Red lamp error message for red A or red B defective, error OFF activated for red defective.
- Adjust monitoring for blind module OFF.
- If other power cards are selected for a group, they are given the same defaults.

All other monitoring functions can be activated when needed.

6.7.2.1 Number of power cards

The required number of power cards for the selected group is adjusted in this box. Default is one power card per group. Maximum four power cards can be selected per group. The corresponding cards are then shown to select the monitoring for each group.

Signal safeguarding

Group: **1** 2 3 4 5 6 7 8 9 10 11 12 13 14 15 16 17 18 19 20 21 22 23 24

Power card Power cards count <input type="text" value="1"/> for group 1	Designation <input type="text" value="K1.1/K1.2"/>	Power cards count <input type="text" value="8"/>
---	--	--

Index card 1

Monitored lamp outputs <input checked="" type="checkbox"/> Red A <input type="checkbox"/> Red B <input type="checkbox"/> Yellow <input type="checkbox"/> Green	Status monitoring <input checked="" type="checkbox"/> Red A <input checked="" type="checkbox"/> Red B <input checked="" type="checkbox"/> Yellow <input checked="" type="checkbox"/> Green
--	--

Error message for red lamp <input checked="" type="radio"/> Red A defective <input type="radio"/> Red A and red B defective	Note: Status monitoring must be disabled for all lamp outputs where no lamp or no LED module is connected
--	--

The name of the current group appears in **Name** and the total number of current power cards appears in **Total power cards**.

The number of power cards only has to be increased if for example there are more than two individually monitored red lamps in any one direction.

Notes:

- If there are several power cards for one group, their switching functions are performed in parallel. However, separate monitoring can also be selected.
- The total number of all power cards is limited to 48.

6.7.2.2 Lamp monitoring

Monitoring for defective lamps can be adjusted separately per group/card. The default is red B. Red B, yellow and green can also be activated (alternatively) when needed.

If several signal heads are connected to one power card, monitoring is only triggered when all lamps of the monitored colour are defective.

If e.g. three signal heads are connected to a group, as a rule red A is connected separately.

The other red lamps are connected to red B; yellow and green are all parallel.

The setting adjusted for error message for red lamps defines when an error message appears for defective red lamps on a card.

The default is red A or red B defective. This option is not available for green and yellow, as all yellow and green lamps are connected in parallel.

Note:

If a power card has only one monitored red lamp, **Red A and red B defective** is disabled. These settings can be adjusted separately for each group / power card.

6.7.2.3 Status monitoring

Status monitoring can be activated for each group/card. In the default setting, it is activated for all groups. This monitoring function permanently checks the nominal/actual status of every single lamp output.

If a deviation is found, the controller switches off with the corresponding error status.

Note:

Depending on the signal pattern when an error occurs, the controller can also be switched off with another error message (e.g. green / green, red / green error).

6.7.2.4 Controller error off

This selection block defines when the controller should switch off for a reported lamp error.

The selection per card is only enabled if the corresponding lamp monitoring is activated.

The default is always **Yes**.

If each group has several cards, this increases the number of possible settings.

A logic selection is also available. The default is OR.

Logic possibilities:

OR = monitoring triggered as soon as a card reports a defective lamp

AND = all cards must report a defective lamp for the chosen colour.

For red error:

If red A or red B lamp monitoring is activated for a card, triggering for red error is automatically triggered for this group.

For yellow error:

If yellow lamp monitoring is activated for a card, triggering for yellow error is automatically triggered for this group.

For green error:

If green lamp monitoring is activated for a card, triggering for green error is automatically triggered for this group.

6.7.2.5 Example lamp monitoring (error)

Number of monitored lamps per card

Group 1s= two power cards

Card 1 = red A, red B, yellow and green monitored, error message for red A or red B error.

Card 2 = red A, yellow and green monitored, error message for red A error.

Signal safeguarding

Group: **1** 2 3 4 5 6 7 8 9 10 11 12 13 14 15 16 17 18 19 20 21 22 23 24

Power card
Power cards count: 2 for group 1

Designation
K1.1/K1.2

Power cards count
9

Index card 1 | Index card 2

Monitored lamp outputs
 Red A Red B Yellow Green

Status monitoring
 Red A Red B Yellow Green

Error message for red lamp
 Red A or red B defective
 Red A and red B defective

Note:
Status monitoring must be disabled for all lamp outputs where no lamp or no LED module is connected

Index card 1 | Index card 2

Monitored lamp outputs
 Red A Red B Yellow Green

Error message for red lamp
 Red A defective
 Red A and red B defective

Controller trigger:

Card 1 reports red lamp error when red A or red B defective – card 2 only when red A defective. The controller switches to red lamp error as soon as card 1 or card 2 of group 1 reports a red lamp error.

Card 1 + 2 report yellow lamps defective: the controller switches to yellow lamp error when card 1 of group 1 reports that the yellow lamps are defective.

Card 1 + 2 report green lamps defective: the controller switches to green lamp error when card 1 of group 1 reports that the green lamps are defective.

6.7.3 Signal safeguarding EPB 12

Entering the monitoring details for controller type EPB 12 is the same as for controller type EPB 24 / EPB 48.

The entry functions are just adapted to the corresponding controller functions of EPB 12.

Signal safeguarding, group 1 (K1.1/ K1.2)

Signal safeguarding

Group: 1 2 3 4 5 6 7 8 9 10 11 12

Designation
K1.1/ K1.2

Monitored lamp outputs
 Red A Red B Yellow Green

Status monitoring
 Red A Red B Yellow Green

Error message for red lamp
 Red A defective
 Red A and red B defective

Adjust monitoring for blind module
 Yes
 No

Controller error off
 Error red Error yellow Error green

Note:
Status monitoring must be disabled for all lamp outputs where no lamp or no LED module is connected

Copy Delete Cancel Ok

The following differences apply compared to controller type EPB 24 / EPB 48:

Controller type EPB 12 has only one power card for each signal group so it is not possible to activate further power cards for a group.

There is therefore no logic choice for error OFF.

6.7.4 Red lamp monitoring MPB 4xxx

The red lamp monitoring functions are adjusted in this mask.

The entries are adjusted to the selected controller type / version. Boxes that are not needed are disabled and shown cross-hatched.

Prg./Grp	1	2	3	4	5	6	7	8	9	10	11	12	13	14	15	16	17	18	19	20	21	22	23	24
P1	✓	✓	✓	✓	✓	✓	✓	✓	✓	✓	✓	✓												
P2	✓	✓	✓	✓	✓	✓	✓	✓	✓	✓	✓	✓												
P3	✓	✓	✓	✓	✓	✓	✓	✓	✓	✓	✓	✓												
P4	✓	✓	✓	✓	✓	✓	✓	✓	✓	✓	✓	✓												
P5																								
P6																								

All red lamp monitoring functions are activated in the basic status. If the intersection time plan editor is closed, red lamp monitoring is automatically disabled for all groups that have no green phase (group off).

If the monitoring list has been changed on closing the intersection time plan editor, the following message appears:

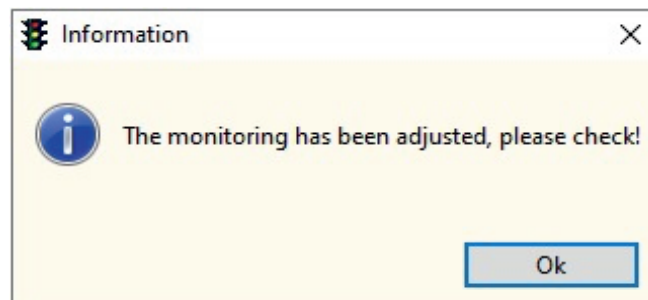

After confirmation, the monitoring mask is shown for checking the data.

Note:

If tactile signal heads are connected to these controller types, red lamp monitoring must be disabled for these groups.

6.8 Radio clock / Progressive signalling

This menu manages the functions and additional data of the optional radio clock.

Note:

These parameters are only supported by controller types EPB 12 / EPB 24 / EPB 48.

6.8.1 Function sync. inputs

Defines how the respective sync. input is evaluated, depending on the operating mode.

Radio clock sync. inputs	Sync. input 1 (terminals)	Sync. input 2 (terminals)
Evaluate for operation mode:	Evaluate for operation mode:	Evaluate for operation mode:
<input type="checkbox"/> Manual	<input checked="" type="checkbox"/> Manual	<input checked="" type="checkbox"/> Manual
<input type="checkbox"/> Operation clock	<input checked="" type="checkbox"/> Operation clock	<input checked="" type="checkbox"/> Operation clock
<input checked="" type="checkbox"/> Radio clock	<input type="checkbox"/> Radio clock	<input type="checkbox"/> Radio clock
<input type="checkbox"/> External	<input checked="" type="checkbox"/> External	<input checked="" type="checkbox"/> External
<input type="checkbox"/> Emergency program	<input checked="" type="checkbox"/> Emergency program	<input checked="" type="checkbox"/> Emergency program

Three separate inputs can be evaluated for progressive signalling at the controllers.

Every input can be mapped with the mode for which this is queried.

For example, if only radio clock is marked for sync. input 1 (radio clock), this is only evaluated when the radio clock mode is selected. Signals of the other inputs are ignored.

When using a radio clock type V4, the sync. information of the serial protocol (only EPB 12 / EPB 24 / EPB 48 from version 6.60 is also evaluated in operating modes that are active under **Sync. inputs radio clock**.

Note:

These settings are only possible for EPB 12 / EPB 24 / EPB 48 from version 6.10

6.8.2 Radio clock parameters

The additional data for radio clock type V4 are adjusted in this mask.

Note:

These settings are intended for the optional radio clock type V4 (only EPB 12 / EPB 24 / EPB 48), from version 6.6x.

Radio clock settings

Recalculation procedure
Beginning year (Siemens 2)

Offset times

Program 1	Program 2	Program 3	Program 4	Program 5	Program 6
0	0	0	0	0	0
Program 7	Program 8	Program 9	Program 10	Program 11	Program 12
0	0	0	0	0	0

Execute for: DCF - Time Sync. input 1 (terminals) Sync. input 2 (terminals)

Delete Cancel Ok

6.8.2.1 Recalculation procedure

The recalculation procedure with which the radio clock calculates the time for output of the sync. pulse is adjusted here.

The radio clock supports the following recalculation procedures:

- Start of year (Siemens 2)
- Start of month
- Start of day
- 01/01/1980 (Siemens 3)

The type of recalculation procedure that has to be used depends on the site and must be queried with the client.

6.8.2.2 Offset time

The values entered for offset time define the delay with which the sync. pulse (internal) received in the controller is evaluated.

This option can be used to adjust the progressive signalling (synchronisation does not fit) on site without changing the intersection time plan or radio clock data.

The entered offset time can be filtered out separately for each sync. input. The default is active for all. This function can be assigned to the respective sync. input at the bottom (**Execute for**).

Display:

If the controller display shows a * before the current time, this shows that an offset time is running.

6.8.3 Radio clock protocol mode

The additional data for the protocol mode of radio clock type V4 are adjusted in this mask. In the protocol mode, the radio clock is supplied automatically from the traffic lights controller. But this only applies if the radio clock is set (receive valid time information).

Note:

This function is only possible for EPB 12 / EPB 24 / EPB 48 from version 6.50

The screenshot shows a configuration window titled "Radio clock protocol mode". It has a yellow background and a standard window border with minimize, maximize, and close buttons. The "Operating mode" is set to "Automatic" in a dropdown menu. Below this, there are three radio buttons: "Send min. circulation time" (which is selected), "Send max. circulation time", and "Send fixed circulation time". Underneath, there is a section titled "Always send this circulation time" containing 12 spinners, labeled "Program 1" through "Program 12", each with a value of "0". At the bottom right, there are three buttons: "Delete", "Cancel", and "Ok".

6.8.3.1 Operating mode

There are various operating modes for the protocol code. The standard default is **Automatic**.

Automatic

Data exchange between radio clock and controller takes place automatically in this setting. The radio clock uses the data received from the controller to calculate the synchronisation time and issues the corresponding sync. pulses.

In addition, the internal system time is synchronised with the radio clock. The program changeover takes place at the switching times supplied by the controller (including public holidays and special switching points).

Manual

On choosing this setting, it is possible to select which cycle times are sent to the radio clock. The choice is between:

- Min cycle time: the minimum cycle time of the currently active program is always sent to the radio clock.
- Max cycle time: the maximum cycle time of the currently active program is always sent to the radio clock.
- Fixed cycle time: the cycle times for the currently active program are sent as entered in the boxes under **Always send this cycle time**.

Only evaluate date / time

With this setting, only the system time of the controller is synchronised with the current time information of the radio clock. No other data are sent to the radio clock.

Protocol mode off

The protocol mode is switched off in this setting. The display only shows the received data of the radio clock.

6.8.4 Radio clock type BCD

If radio clock type BCD is used in the controller, it must be supplied with data from its own software.

This clock then automatically switches the day programs and the progressive signalling pulse on the basis of the supplied data.

Note:

The DCF clock mode must be adjusted at the controller for changeover of the day programs by the radio clock. This does not happen in other operating modes.

The progressive signalling pulse is also evaluated in other modes, depending on the setting.

☞ 6.8.1

6.8.5 Serial radio clock

If the serial radio clock is used in the controller, the basic supply is based on the adjusted intersection time plans (cycle times, sync. points, etc.)

All that has to be entered is the recalculation procedure and the offset times, if needed. ☞ 6.8.1

This type of radio clock only works with one program. The current corresponding data such as cycle time, sync. point and recalculation procedure are constantly transmitted to the radio clock and used only for output of the progressive signalling pulse.

Note:

This version is only supported from version 6.60 (only EPB 12 / EPB 24 / EPB 48). With this variant, the radio clock is only used for output of the progressive signalling pulse. Program changeovers are carried out by the controller itself, as the radio clock always sends the current date and time.

6.9 Program switching points

This menu point is used to manage the weekly automatic (switching points) for clock mode and radio clock (only EPB 12 / EPB 24 / EPB 48 from version 6.60).

In controller types EPB 12 / EPB 24 / EPB 48 from version 6.6x, the weekly automatic clock mode and radio clock can be supplied separately.

Furthermore, the weekly automatic radio clock also supports public holidays and 20 special switching points (free entry).

An option allows the weekly automatic radio mode to be used for clock mode as well: it is then no longer necessary to enter the weekly automatic for clock mode.

6.9.1 Weekly automatic clock mode

Use this window to enter the switching points for **clock mode**.

The entries are adjusted to the selected controller type / version. Boxes that are not needed are disabled and shown cross-hatched.

The number of visible programs changes according to the program release.  6.1.7

Note:

The controller (only EPB 12 / EPB 24 / EPB 48) does not accept switching to the clock mode if no switching points have been entered. A corresponding message appears.

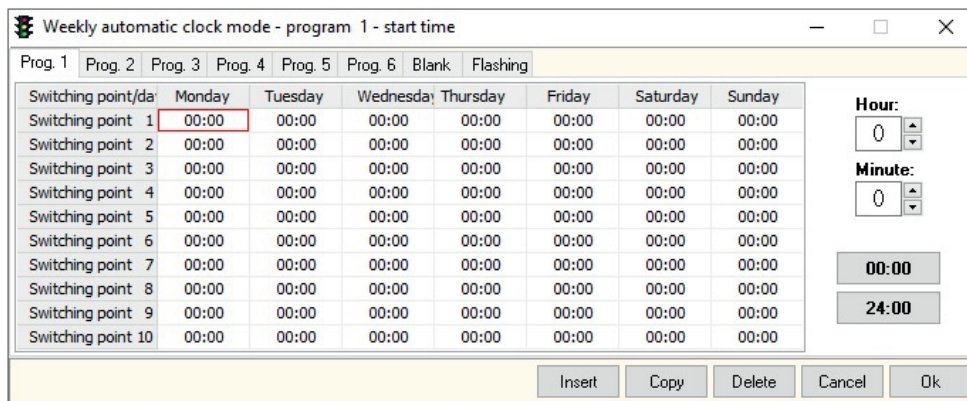

Prog. 1	Prog. 2	Prog. 3	Prog. 4	Prog. 5	Prog. 6	Blank	Flashing		
Switching point/da	Monday	Tuesday	Wednesday	Thursday	Friday	Saturday	Sunday		
Switching point 1	00:00	00:00	00:00	00:00	00:00	00:00	00:00		
Switching point 2	00:00	00:00	00:00	00:00	00:00	00:00	00:00		
Switching point 3	00:00	00:00	00:00	00:00	00:00	00:00	00:00		
Switching point 4	00:00	00:00	00:00	00:00	00:00	00:00	00:00		
Switching point 5	00:00	00:00	00:00	00:00	00:00	00:00	00:00		
Switching point 6	00:00	00:00	00:00	00:00	00:00	00:00	00:00		
Switching point 7	00:00	00:00	00:00	00:00	00:00	00:00	00:00		
Switching point 8	00:00	00:00	00:00	00:00	00:00	00:00	00:00		
Switching point 9	00:00	00:00	00:00	00:00	00:00	00:00	00:00		
Switching point 10	00:00	00:00	00:00	00:00	00:00	00:00	00:00		

Always enter the start time of the respective program, selecting the week day of the corresponding program.

Enter the required switching time either directly with the keyboard or adjust the setting with the up/down arrow buttons. The shortest switching interval is 1 minute.

Clicking on **00:00** or **24:00** adjusts the dates in the marked box to this value. No switching is triggered by 00:00. You must enter 24:00 to trigger switching at midnight.

Note:

If the switching time is entered e.g. as Saturday 24:00 h, this switching command is switched at 0:00 h on Sunday.

Click on **Copy** to save the value in the currently marked box. Use **Insert** to insert this value in other boxes.

As soon as you leave an input box, the system checks whether this switching time already exists. If so, a corresponding message appears with information about the program where this switching time was already entered.

When programming switching times, they also have to be entered on the days when no program change takes place.

The entry must include the program that is active on this day. The switching time is entered as 00:01. The time is entered as 00:01 because this is the first possible switching time on a new day. If no program change is made on a certain day and the system shuts down (fault, power failure etc.), when rebooted the controller looks for the program active on the respective day.

If the switching points have no entry for the day, the controller starts automatically with the emergency program. This continues until a program change is triggered by the clock.

Notes:

- The system does not change to another program until there is a new switching command.
- The date and time in the controller must be correct for the programs to be changed over properly. The clock in the controller is always adjusted to the PC time as soon as a program is transferred to the controller.

6.9.2 Weekly automatic radio clock

The weekly automatic is entered in three separate entry masks.

- **Day's schedule / weekly schedule**
In this entry mask, the switching times of the individual day's schedule are assigned to the respective weekly schedule. This is done in so-called the day's schedule.
- **Public holidays**
A day's schedule is assigned to the required public holidays in this entry mask.
- **Special switching points**
Up to 20 special switching points (free date) can be managed in this entry mask. A day's schedule can be assigned for every special switching point.

Note:

If you switch to the radio clock when no switching points have been entered, a corresponding message appears in the display.

Although the controller changes to the radio clock, the protocol mode (supplying the radio clock via the controller CPU) is switched off. The controller then evaluates the internal supply of the radio clock and program switching takes place with the corresponding entries.

6.9.2.1 Weekly schedules / day's schedules

This entry mask is used to enter the weekly schedule and day's schedule.

Day	Plan	Plan description
Monday		
Tuesday		
Wednesday		
Thursday		
Friday		
Saturday		
Sunday		

No.	Start time	Program	Program description
1			
2			
3			
4			
5			
6			
7			
8			
9			
10			
11			
12			
13			
14			
15			

6.9.2.1.1 Enter day's schedules

Up to 10 day's schedules can be entered with maximum 90 switching times each. Every day's schedule can also be given a name.

The individual day's schedules are then assigned to the individual weekly schedules.  **6.9.2.1.3**

No.	Start time	Program	Program description
1			
2			
3			
4			
5			
6			
7			
8			
9			
10			
11			
12			
13			
14			
15			

Click the right mouse button in an empty line to open a selection menu.

Use **New entry** to create a new entry: the entry mode appears.

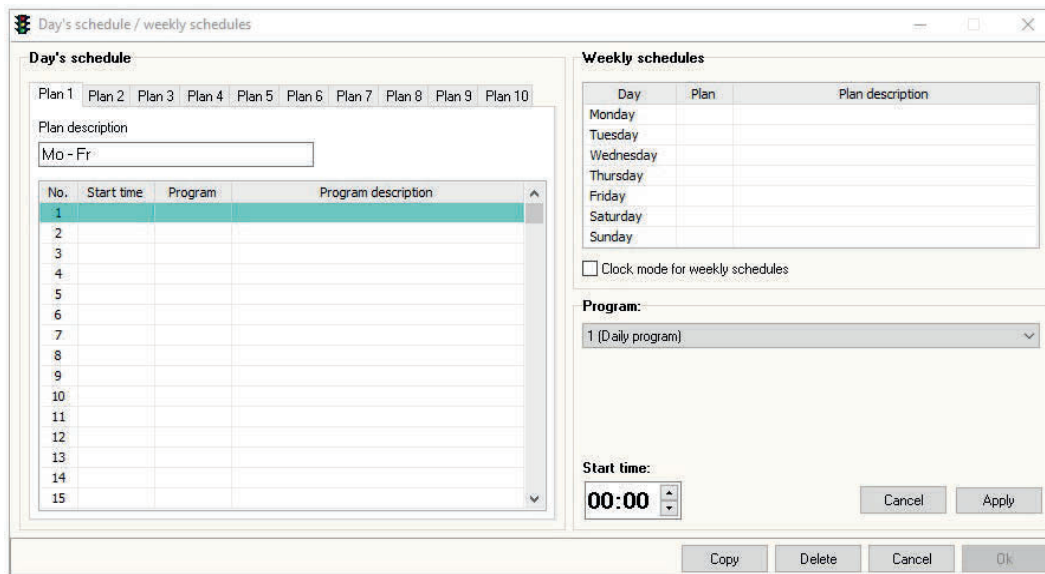

Select the required program and switching time, then click on **Save** to enter the data in the list. The list is sorted automatically according to the smallest switching time. If the current switching time already exists, a corresponding message appears.

Note:

If 00:00 h is selected as switching time, 24:00 h appears as first in the list. If the switching time is entered e.g. as Saturday 24:00 h, this switching command is switched at 0:00 h on Sunday.

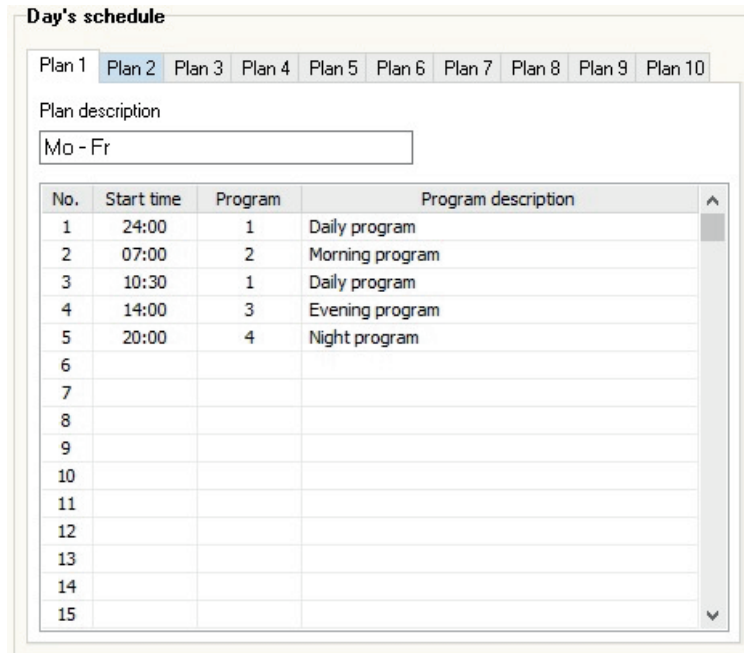

To edit an existing switching point, mark the entry with the right mouse button and select **Edit entry**. Alternatively, simply double click on the corresponding entry. The entry mode appears in both cases.

6.9.2.1.2 Switch parameter lists / special functions

As from version 7.10 (system type EPB 12 / EPB 24 / EPB 48) it is possible to switch parameters lists or special functions.

The selection box for the program being switched also includes continuous red, blanking and parameter lists 1 to 24.

For greater clarity, the respective parameter lists are shown with the corresponding designation (if one exists).

The screenshot shows the 'Day's schedule / weekly schedules' window. The 'Day's schedule' section contains a table with the following data:

No.	Start time	Program	Program description
1	24:00	1	Basic program
2	06:00	Param. 1	Morning
3	09:00	Param. 2	Midday
4	12:00	Param. 3	Afternoon
5	15:00	Param. 4	Evening
6	20:00	Param. 5	Night
7			
8			
9			
10			
11			
12			
13			
14			
15			

The 'Weekly schedules' section shows a table with the following data:

Day	Plan	Plan description
Monday	1	Mo - Fr
Tuesday	1	Mo - Fr
Wednesday	1	Mo - Fr
Thursday	1	Mo - Fr
Friday	1	Mo - Fr
Saturday	1	Mo - Fr
Sunday	1	Mo - Fr

Below the weekly schedules table is a checked checkbox for 'Clock mode for weekly schedules' and a 'Program:' dropdown menu showing '1 (Basic program)'. The 'Start time:' field is set to '22:00'. Buttons for 'Cancel' and 'Apply' are visible. At the bottom of the window are 'Copy', 'Delete', 'Cancel', and 'Ok' buttons.

Notes:

- As soon as a parameter list is opened, the current day program remains active, but with other parameters for the extension times.
- If a parameter list is opened that has no times, this is not executed.
- At least one day program must be entered for every day plan. It is not possible to enter just parameter lists: in this case, the current day plan cannot be allocated to a week day.
- Opening another day program does not cancel the current parameter list. The current parameter list remains in use. To end a parameter list, enter the required switching time and select "Parameter list off" in the right-hand selection box.
- If you want to switch a program and a parameter list at the same time, enter the same time for both functions. In this case, it is possible that these two switch commands are not carried out at the same time, because the parameter list is adopted immediately at the selected time, while the program change is only implemented with the GSP.
- An active parameter list ends automatically by default as soon as the operating mode changes or another program or special mask is active. The extension times of the now active program then apply. This behaviour can be configured under point 6.5.4.
- Continuous red as switching request is only implemented if there is a continuous red point in the active program.
- The blanking switching request is only implemented if this function has been enabled.

6.9.2.1.3 Enter weekly schedules

If day's schedules have been entered, a day's schedule must be assigned to every day in the weekly schedules.

Weekly schedules

Day	Plan	Plan description
Monday		
Tuesday		
Wednesday		
Thursday		
Friday		
Saturday		
Sunday		

Clock mode for weekly schedules

The assignment is done in the Plan column with the right mouse button. Use **Delete entry** to delete the entry for the current weekday. **Cancel** closes the selection menu.

Weekly schedules

Day	Plan	Plan description
Monday		
Tuesday		
Wednesday		
Thursday		
Friday		
Saturday		
Sunday		

Clock mode for weekly schedules

- Plan 1 (Mon - Thu)
- Plan 2 (Fri)
- Plan 3 (Sat)
- Plan 4 (Sun)
- Plan 5 (Public holiday)
- Plan 6 (Special plan)
- All weekdays >
- Cancel

Note:

Delete entry only appears if a day's schedule has already been entered for the marked entry. Click the left mouse button on the selected day's schedule and enter it in the current weekly schedule.

Weekly schedules

Day	Plan	Plan description
Monday	1	Mon - Thu
Tuesday	1	Mon - Thu
Wednesday	1	Mon - Thu
Thursday	1	Mon - Thu
Friday	2	Fri
Saturday	3	Sat
Sunday	4	Sun

Clock mode for weekly schedules

Note:

A day's schedule must be assigned to every weekly schedule. If this is not the case, a corresponding error message appears on attempting to close the mask. The mask cannot be closed if the entries are incomplete.

To assign a day's schedule to all days of the week, Select the required day's schedule in **All weekdays**. The day's schedule selected here is then entered for all weekdays in the weekly schedules.

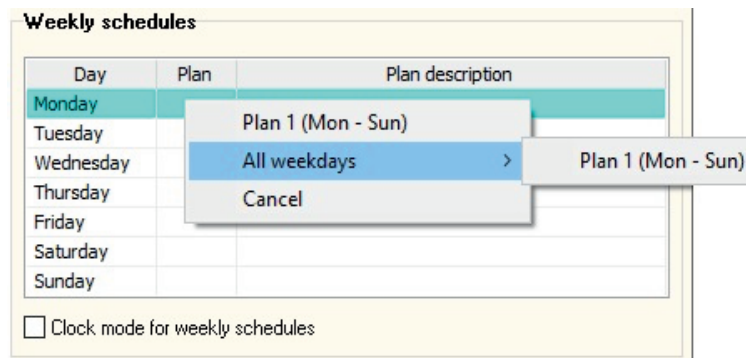

6.9.2.1.4 Weekly schedule error display

If day's and weekly schedules are present and program releases are removed from used programs, these entries are marked in colour. The controller does not carry out this switch request and remains in the current program until a valid switch request is present.

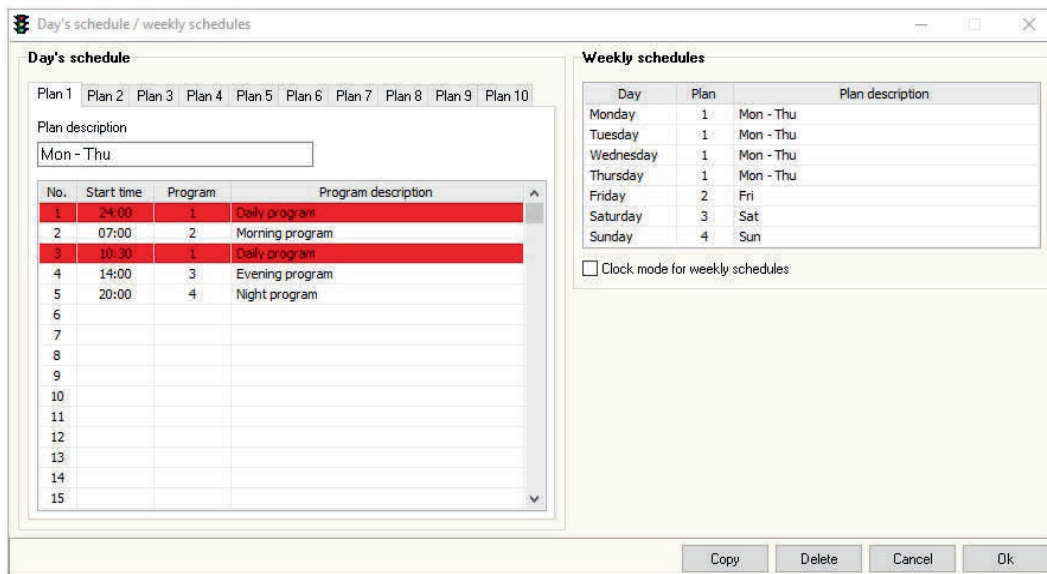

6.9.2.1.5 Clock mode for weekly schedules

If **Clock mode for weekly schedules** is enabled, the existing switching times of the weekly automatic radio clock are then also used in clock mode.

Note:

If this option is enabled and switching times are present in the weekly automatic clock mode, these are not used because priority is given to the switching times of the weekly automatic radio mode.

6.9.2.2 Public holidays

The menu points for entering public holidays are enabled as soon as day's schedules / weekly schedules are available.

Special day's schedules can be assigned for these public holidays.

Fixed public holidays			Floating public holidays		
Day	Plan	Plan description	Day	Plan	Plan description
New Year's Day (1 January)			Women's Carnival Day		
Berchtoldtag (2 January - Switzerland)			Carnival Monday		
Epiphany (6 January)			Pancake Tuesday		
Valentine's Day (14 February)			Ash Wednesday		
Josefstag (19 March - Austria)			Maundy Thursday		
Labour Day (1 May)			Good Friday		
Swiss national holiday (1 August)			Easter Sunday		
Peace Festival (8 August)			Easter Monday		
Assumption of Mary (15 August)			Ascension Day		
German Unification Day (3 October)			Mother's Day		
National holiday in Austria (26 October)			Whit Sunday		
Reformation Day (31 October)			Whit Monday		
All Saints (1 November)			Holy Trinity		
St Nicholas Day (6 December)			Corpus Christi		
Feast of the Immaculate Conception (8 December)			Day of repentance and prayer		
Christmas Eve (24 December)			1st Sunday in Advent		
Christmas Day (25 December)			2nd Sunday in Advent		
Boxing Day (26 December)			3rd Sunday in Advent		
New Year's Eve (31 December)			4th Sunday in Advent		
			Not a public holiday		
			Ascension Day in Switzerland		

Note:

Switch commands for public holidays are only evaluated with the radio clock type V4 in the protocol mode (EBP 48 / 12 from version 6.60).

6.9.2.2.1 Enter fixed public holidays

In this selection list, the required day's schedules are assigned to the fixed public holidays (always on the same date).

The assignment is done in the **Plan** column with the right mouse button.

Use **Delete entry** to delete the entry for the current weekday.

Cancel closes the selection menu.

Day	Plan	Plan description
New Year's Day (1 January)		
Berchtoldtag (2 January - Switzerland)		
Epiphany (6 January)		
Valentine's Day (14 February)		
Josefstag (19 March - Austria)		
Labour Day (1 May)		
Swiss national holiday (1 August)		
Peace Festival (8 August)		
Assumption of Mary (15 August)		
German Unification Day (3 October)		
National h	Plan 1 (Mon - Thu)	
Reformati	Plan 2 (Fri)	
All Saints	Plan 3 (Sat)	
St Nichola	Plan 4 (Sun)	
Feast of t	Plan 5 (Public holiday)	
Christmas	Plan 6 (Special plan)	
Christmas	Public holidays by state	
Boxing Da	Cancel	
New Year		

Click the left mouse button on the selected day's schedule and enter it for the marked public holiday.

Fixed public holidays		
Day	Plan	Plan description
New Year's Day (1 January)		
Berchtoldtag (2 January - Switzerland)		
Epiphany (6 January)		
Valentine's Day (14 February)		
Josefstag (19 March - Austria)		
Labour Day (1 May)		
Swiss national holiday (1 August)	5	Public holiday
Peace Festival (8 August)		
Assumption of Mary (15 August)		
German Unification Day (3 October)	5	Public holiday
National holiday in Austria (26 October)		
Reformation Day (31 October)		
All Saints (1 November)	5	Public holiday
St Nicholas Day (6 December)		
Feast of the Immaculate Conception (8 December)		
Christmas Eve (24 December)		
Christmas Day (25 December)		
Boxing Day (26 December)		
New Year's Eve (31 December)		

Note:

Delete entry only appears if a day's schedule has already been entered for the marked entry.

6.9.2.2.2 Enter floating public holidays

In this selection list, the required day's schedules are assigned to the floating public holidays.

Floating public holidays		
Day	Plan	Plan description
Women's Carnival Day		
Carnival Monday		
Pancake Tuesday		
Ash Wednesday		
Maundy Thursday		
Good Friday		
Easter Sunday		
Easter Monday		
Ascension Day		
Mother's Day		
Whit Sunday		
Whit Monday		
Holy Trinity		
Corpus Christi		
Day of repentance and prayer		
1st Sunday in Advent		
2nd Sunday in Advent		
3rd Sunday in Advent		
4th Sunday in Advent		
Not a public holiday		
Ascension Day in Switzerland		

Mapping is the same as for the fixed public holidays  **6.9.2.2.1**

6.9.2.2.3 Enter public holidays by state

If you select **Public holidays by state**, another entry mask appears.

Fixed public holidays			Floating public holidays		
Day	Plan	Plan description	Day	Plan	Plan description
New Year's Day (1 January)			Women's Carnival Day		
Berchtoldtag (2 January - Switzerland)			Carnival Monday		
Epiphany (6 January)			Pancake Tuesday		
Valentine's Day (14 February)			Ash Wednesday		
Josefstag (19 March - Austria)			Maundy Thursday		
Labour Day (1 May)			Good Friday		
Swiss national holiday (1 August)			Easter Sunday		
Peace Festival (8 August)			Easter Monday		
Assumption of Mary (15 August)			Ascension Day		
German Unification Day (3 October)			Mother's Day		
National holiday in Austria (26 October)			Whit Sunday		
Reformation Day (31 October)			Whit Monday		
All Saints (1 November)			Holy Trinity		
St Nicholas Day (6 December)			Corpus Christi		
Feast of the Immaculate Conception (8 December)			Day of repentance and prayer		
Christmas Eve (24 December)			1st Sunday in Advent		
Christmas Day (25 December)			2nd Sunday in Advent		
Boxing Day (26 December)			3rd Sunday in Advent		
New Year's Eve (31 December)			4th Sunday in Advent		
			Not a public holiday		
			Ascension Day in Switzerland		

Fixed public holidays			Floating public holidays		
Day	Plan	Plan description	Day	Plan	Plan description
New Year's Day (1 January)			Women's Carnival Day		
Berchtoldtag (2 January - Switzerland)			Carnival Monday		
Epiphany (6 January)			Pancake Tuesday		
Valentine's Day (14 February)			Ash Wednesday		
Josefstag (19 March - Austria)			Maundy Thursday		
Labour Day (1 May)			Good Friday		
Swiss national holiday (1 August)			Easter Sunday		
Peace Festival (8 August)			Easter Monday		
Assumption of Mary (15 August)			Ascension Day		
German Unification Day (3 October)			Mother's Day		
National holiday in Austria (26 October)			Whit Sunday		
Reformation Day (31 October)			Whit Monday		
All Saints (1 November)			Holy Trinity		
St Nicholas Day (6 December)			Corpus Christi		
Feast of the Immaculate Conception (8 December)			Day of repentance and prayer		
Christmas Eve (24 December)			1st Sunday in Advent		
Christmas Day (25 December)			2nd Sunday in Advent		
Boxing Day (26 December)			3rd Sunday in Advent		
New Year's Eve (31 December)			4th Sunday in Advent		
			Not a public holiday		
			Ascension Day in Switzerland		

Use the sub-menu to select the required state and day's schedule. **OK** presets the corresponding public holidays in the adjusted day's schedule for the selected state.

Note:

Manual editing is still possible after presetting the public holidays as defaults by state.

6.9.2.3 Special switching points

Up to 20 free switching points are managed in this mask with a date and day's schedule mapped to every special switching point. The special switching points are only switched once on the stipulated date without annual repetition.

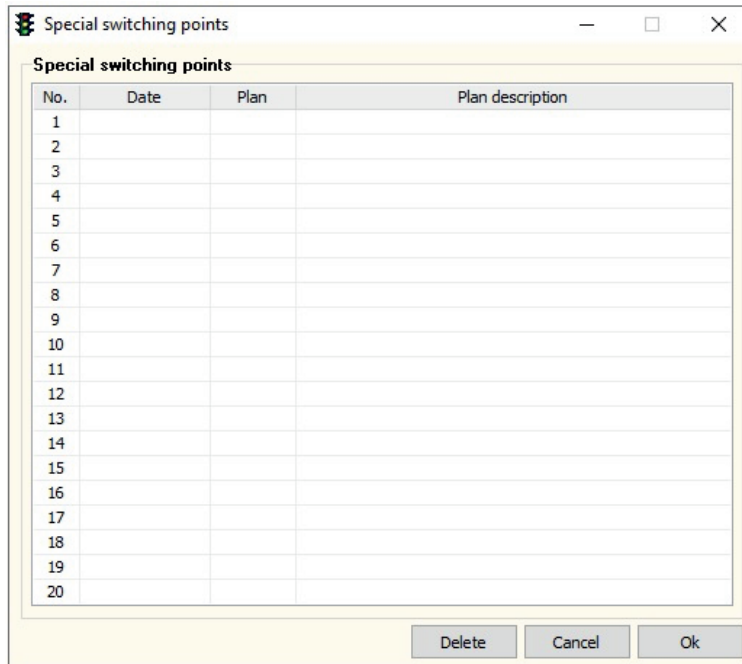

No.	Date	Plan	Plan description
1			
2			
3			
4			
5			
6			
7			
8			
9			
10			
11			
12			
13			
14			
15			
16			
17			
18			
19			
20			

Note:

The controller treats special switching points with maximum priority, giving them preference over all other switching points.

6.9.2.3.1 Enter special switching points

Click the right mouse button in a line to open a selection menu.

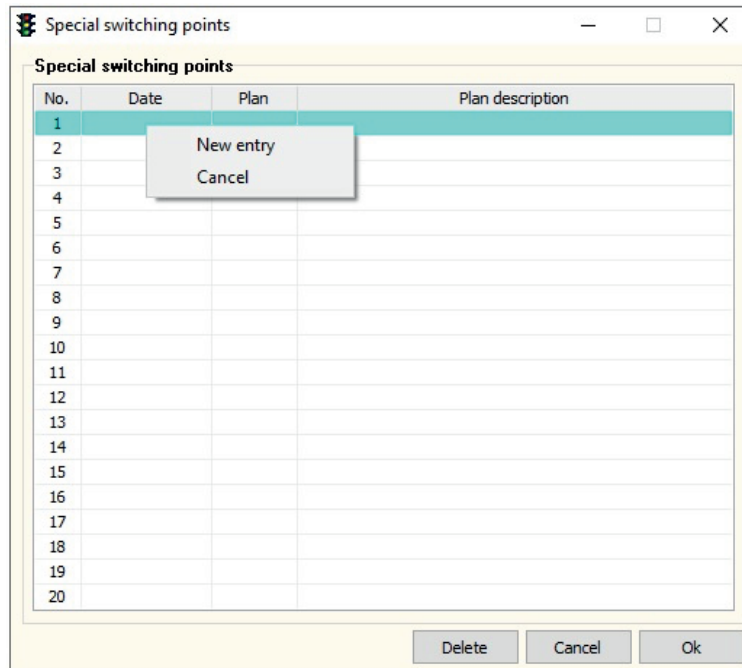

Click on **New entry** to open a calendar. Click on **Cancel** to close the selection menu. If you click on **New entry**, you will see a calendar (the current day is marked) for selecting the required day to which a special plan should be switched.

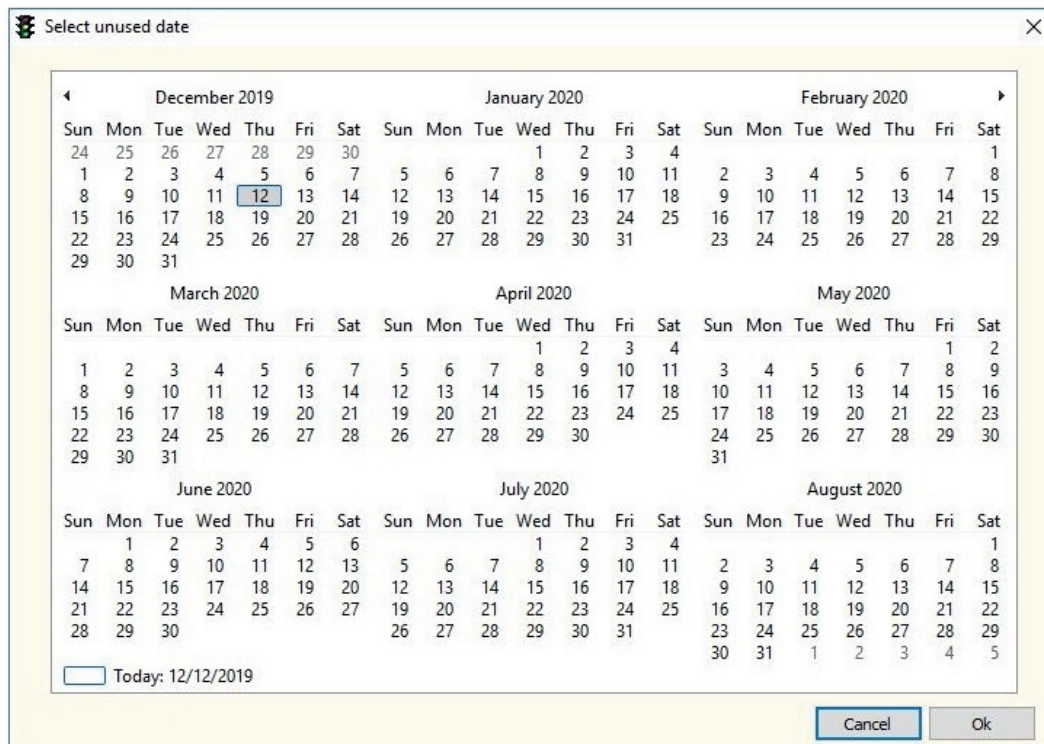

In the calendar, select the required date with the left mouse button.
OK saves the selected date in the list:

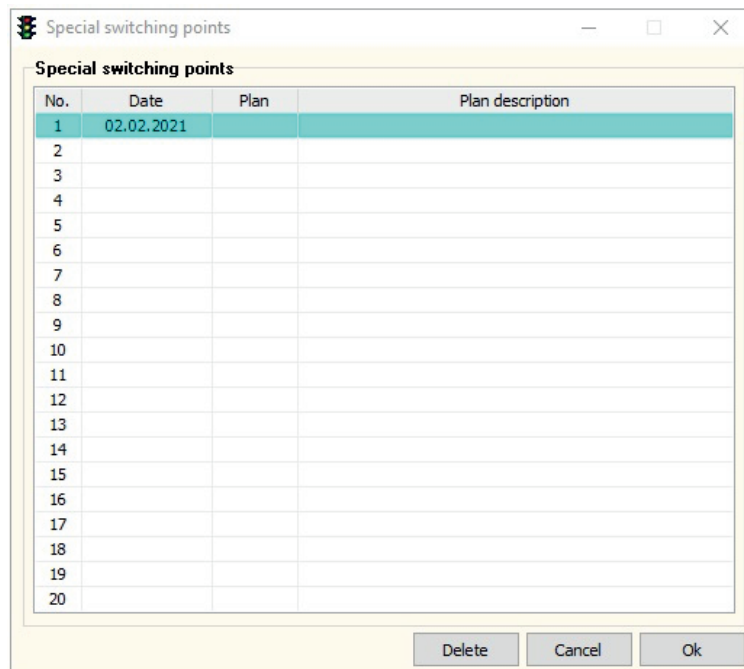

Note:

The list is sorted automatically according to the smallest date. If a date already exists, a corresponding message appears.

Click the right mouse button in the line with the existing date to open a selection menu with the existing weekly schedules.

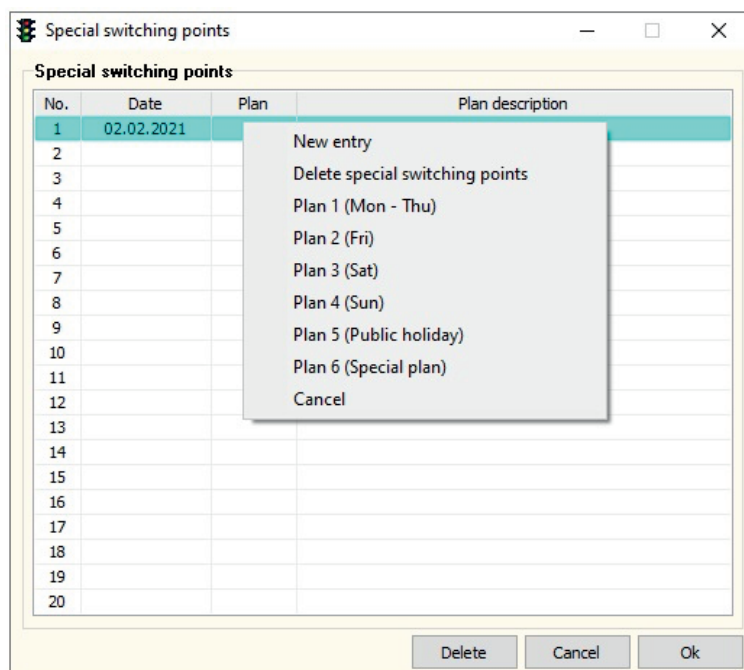

Use the left mouse button to select the required weekly schedule to be switched on this date.

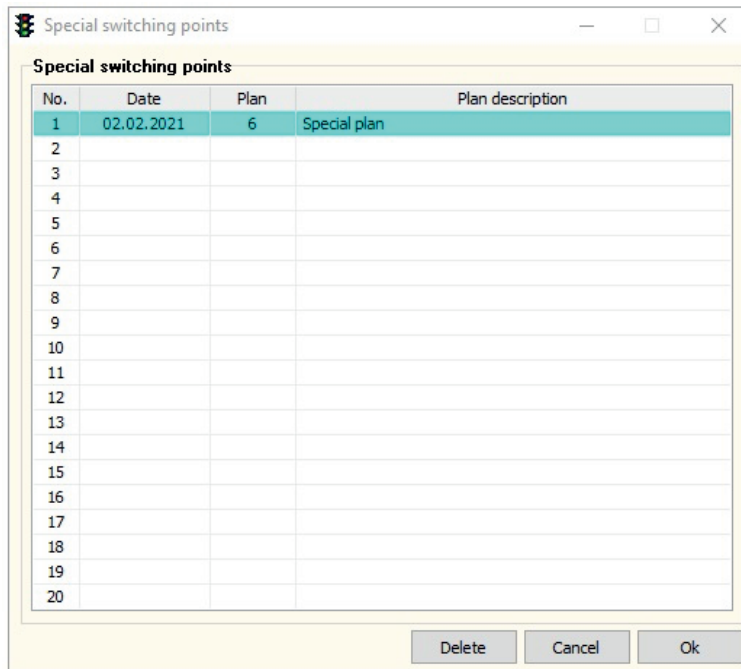

The selection menu closes again and the selected weekly schedule is assigned to the marked date.

6.9.2.2.3 Error display for public holidays and special switching points

If day's and weekly schedules are present and program releases are removed from used programs, the corresponding points in the menu structure are marked with an error symbol.

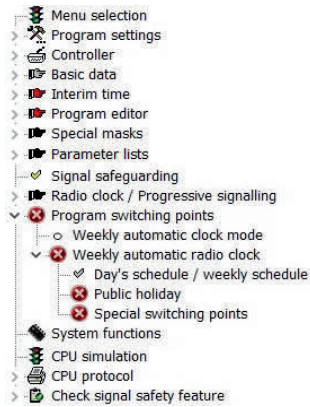

The controller does not carry out this switch request and remains in the current program until a valid switch request is present.

These entries are marked in colour in the respective entry masks.

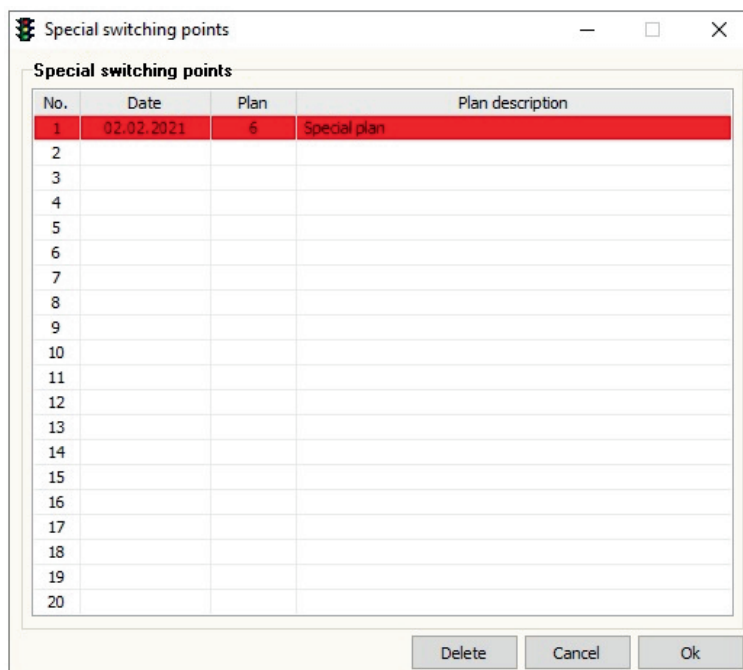
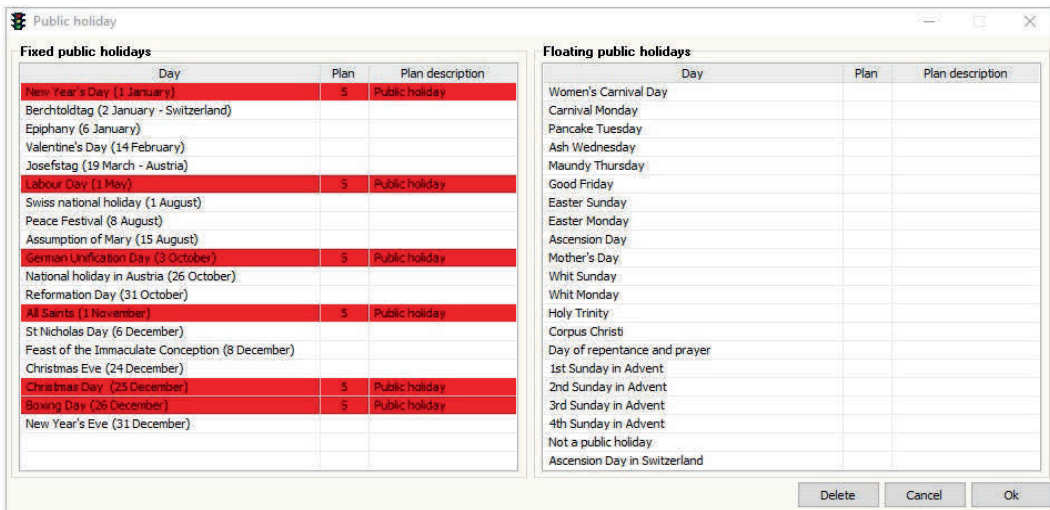

6.10 System functions

This mask is used to manage the system functions (EPB 12 / EPB 24 / EPB 48); some options are disabled or enabled depending on the version.

If options are disabled, they are preset as executed by the adjusted controller type/version.

The screenshot shows the 'System functions' configuration window. It is organized into several panels:

- Relay output:** Contains settings for Error output 1 and 2 (Impulse or Continuous signal, Duration in seconds) and Output Sync 1 and 2 (Inactive after fault, Switch only at SZP, Output duration in seconds).
- Automatic restart after error:** Includes Restart time after error (4 minutes), Restart after error in (1 minute), No restart, Immediately after fault, and Maximum count of restarts with same error (2).
- Function additional relay PWK 24 / 48:** Options for Switch-on relay 1 at green, relay 2 at waiting signal, or Switch manually.
- Display illumination:** Duration (2 minutes), Switch on whenever key pressed, and LSA off (Controller yellow flashing or Controller blank).
- Duration print function:** Duration (20 minutes) and No restriction.
- Miscellaneous:** Includes Preset all groups at manual mode, No telegram progressive signalling inputs for operating log, Send test or check results to operating log book, Preset all groups when emergency program active, Max green when emergency program active, Preset all groups once with manual program selection, External fault input – permanent contact function, Send informative fault messages, and Program change trigger extended on request.
- Active special inputs:** External start, Clear error, External flashing, External error, External manual mode, Emergency program, Key switch clock pulse, and Check key switch.
- Output auxiliary signals:** Waiting signals (Continuous signal) and Acknowledgement signals (Continuous signal).
- Printer interface:** Baud rate selection (1200, 9600, 19200).
- Set clock with radio clock:** Delay after (1 hour).
- LED panel:** Turn off after time (20 minutes).
- Special function sync. points:** Sync. point 1 - fixed duration and Sync. point 2 - fixed duration.

6.10.1 Configuring the relay outputs

The functions for the error outputs and sync. outputs are managed in this box. Not all functions are available, depending on controller type and version.

6.10.1.1 Error outputs

Defines the function of the respective error output (relays, potential-free contacts). Every output can be adjusted separately.

As soon as the controller triggers a program, the relays switch on. They are inactive after a fault, depending on the corresponding setting.

Note:

This function is only supported by controller types EPB 12 / EPB 24 / EPB 48.

6.10.1.1.1 Error output as continuous signal

If this function is selected, the corresponding relay is inactive after a fault and switches on again only when the controller carries out a program again.

6.10.1.1.2 Error output as pulse

If this function is selected, a value can be entered as duration in seconds. It indicates how long the corresponding relay goes off when there is a fault. It switches on again when the time has expired.

6.10.1.2 Sync. outputs

Various sync. output functions (relays, potential-free contacts) can be selected here. The functions can be adjusted separately for each relay.

6.10.1.2.1 Sync. relay inactive after fault

This setting defines the behaviour of the relays when the controller switches off after a fault. If this function is disabled, the corresponding relay is not inactive after a fault. If the controller is without power (power failure), the relays are generally inactive.

Note:

This function can only be changed for EPB 12 / EPB 24 / EPB 48 from version 6.50.

6.10.1.2.2 Sync. relay ON after fault

Enabling the option **Switch only at SZP** changes the function **Sync. relay inactive after fault** to **Sync. relay ON after fault**.

The corresponding relay then switches on continuously after a fault and is inactive as soon as the controller is in operation again.

Note:

This function can only be changed for EPB 12 / EPB 24 / EPB 48 from version 6.50.

6.10.1.2.3 Switch only at SZP

In the default setting, the relays are ON as soon as the controller carries out a program and are inactive at the programmed time for the adjusted duration, or continuously after a fault.

If **Switch only at SZP** is selected, the corresponding relay is always inactive; it switches on only at the programmed time for the adjusted duration.

Note:

This function can only be changed for EPB 12 / EPB 24 / EPB 48 from version 6.50.

6.10.1.3.3 Sync. relay continuous signal

Stipulates the duration of the respective sync. relay when this is inactive or ON (depending on the setting).

Note:

This setting can only be changed for EPB 12 / EPB 24 / EPB 48. It is preset to the fixed duration of two seconds for all other controller types.

6.10.2 Display illumination

The duration for the display illumination can be adjusted. It is also possible to choose the option of switching the illumination on whenever a key is pressed.

In version 6.10, the illumination is set to the fixed duration of two minutes and can only be switched on with the **Light** button.

If the illumination is already on, the time interval is restarted whenever a key is pressed.

Note:

From version 6.30, the light is switched on automatically for the preset time when the controller switches off after a fault.

6.10.3 TLS off

Defines the system status (only EPB 12 / EPB 24 / EPB 48 from version 6.10) when the controller is switched off after TLS off. Flashing is the default setting in older versions.

Flashing only applies to groups with activated error flashing.

6.10.4 Duration print function

The time adjusted here defines the print duration from the controller for the following print commands:

- Print Act.
- Print error report line by line
- Print program change line by line

Notes:

- Print This time can be adjusted from version 6.50 (only EPB 12 / EPB 24 / EPB 48). In older versions or other controllers, this time is preset to a fixed default of 20 minutes.
- From version 7.30 (only EPB 12 / EPB 24 / EPB 48), the time limit can be switched off with the checkbox.

6.10.5 Automatic restart after error

Stipulates the mode for an automatic restart after an error. Not all possibilities are available, depending on the version.

6.10.5.1 Restart time after error

The adjusted time stipulates how long a controller must have been operating error-free until a restart is permitted after an error.

The time is fully variable from version 6.10, and otherwise fixed at one minute.

6.10.5.2 Restart in minutes

If this function is activated, the controller tries a restart one minute after an error. There is no restart if the error is still active. The time is fully variable from version 6.10.

6.10.5.3 No restart after error

On selecting this function, first a query appears whether the automatic restart really should be disabled.

Yes then disables the automatic restart: the controller no longer restarts after an error. This setting makes sense when the system is controlled externally via a central computer or similar.

6.10.5.4 Restart immediately after a fault

If this function is activated, the controller restarts immediately after an error shut-down. This function is only activated after confirming a password.

6.10.5.5 No. restarts after error

Here it is possible to select the number of restarts after the same fault. A keyword query appears before the function is enabled.

Note:

This function can only be chosen freely for controller type EPB 12 / EPB 24 / EPB 48: the option is disabled for other controller types. The function is fixed in controllers MPB 4xxx.

6.10.6 Baud rate printer interface

Producing printouts straight from the controller is only possible on a printer with serial interface. The following parameters must be adjusted at the printer:

1200 baud (1200 / 9600 / 19200, can be selected for EPB 12 / EPB 24 / EPB 48 from version 6.10)
8 bit
Even parity
German character set

Note:

It is not possible to use printers with parallel interface.

6.10.7 Miscellaneous functions

Other system functions are managed here.

6.10.7.1 Groups preset for manual mode

This function defines whether groups set to request are given an internal request as preset in manual mode. The default is **Yes**.

If manual mode is active, those groups switching on request are switched in manual mode. If the function is disabled, only those groups with a request are switched in manual mode.

Note:

This function can only be changed for EPB 12 / EPB 24 / EPB 48 from version 6.50. The function is fixed in other controller types / versions. Groups switching on request are given an internal request as preset when manual mode is switched on.

6.10.7.2 Send no message for progressive signalling inputs

Here it is possible to stipulate whether the switching statuses of the progressive signalling inputs are always sent to the operating logbook. The default is **No**.
If this function is enabled, every change in the sync. inputs is sent to the operating logbook.

Note:

This function can only be changed for EPB 12 / EPB 24 / EPB 48 from version 6.50.
The message is always sent as a fixed feature in versions older than 6.50.

6.10.7.3 Send test or check results to operating logbook

If this option is activated, all error evaluations ascertained when signal safeguarding is being tested are sent to the operating logbook.

Note:

This function is only available for EPB 12 / EPB 24 / EPB 48 from version **6.90**.

6.10.7.4 All groups preset when emergency program active

Use this function to activate a continuous request for all signal groups switching to request as soon as the emergency program (manual choice or automatic) is activated.
The respective groups then switch to green for the minimum release time drawn in the intersection time plan.

Note:

This function is only available for EPB 12 / EPB 24 / EPB 48 from version 7.00.

6.10.7.5 Max green when emergency program active

If this option is activated, the max green function is activated as soon as the emergency program (manual choice or automatic) is activated.
The respective signal groups then always switch their maximum green phase.

Note:

This function is only available for EPB 12 / EPB 24 / EPB 48 from version 7.00.

6.10.7.6 All groups preset once with manual program choice

If this option is activated, a request is preset once for all signal groups switching to request, as soon as a manual program choice is made at the controller.

Note:

This function is only available for EPB 12 / EPB 24 / EPB 48 from version 7.00.

6.10.7.7 External fault input: contact control

Use this function to activate contact control for the external fault input.

If this function is activated, the controller switches to "**External fault**" for as long as there is an external fault input.

If there is no longer an external fault input, the controller starts again in the current mode.

For the external fault input to be evaluated as a general rule, it must be switched on with the active special inputs. ↗ **6.10.9**

Note:

This function is only available for EPB 12 / EPB 24 / EPB 48 from version 7.00.

6.10.7.8 Show informative error reports

If this option is activated, all error reports that do not make the system switch off are entered in an information list.

When there are entries in this list, **F2** flashes top right in the system display. Press **F2** on the keyboard to show the informative error reports.

Note:

This function is currently not available.

6.10.7.9 Extend trigger for program change on request

If this option is activated, program change on request is also triggered when the forced cycle function is carried out or on pressing **Set all requests**.

The detector inputs are then preset for all signal groups that trigger program change on request: just once for the forced cycle, and while the button is pressed for **Set all requests**.

Note:

This function is only available for EPB 12 / EPB 24 / EPB 48 from version 7.10.

6.10.8 Auxiliary signals

These two selection boxes are used to manage the output of waiting respectively auxiliary signals separately for each function.

6.10.8.1 Output waiting signal

Defines the output of the waiting signal. From version 6.50 (only EPB 12 / EPB 24 / EPB 48), this can be a continuous or flashing signal.

Note:

In older versions this function is fixed as a continuous signal.

6.10.8.2 Output acknowledge signals

Defines the output of the acknowledge signals, with a choice between continuous signal or flashing.

Note:

This function is available from version 6.90 (only EPB 12 / EPB 24 / EPB 48).

6.10.9 Active special inputs

These functions can be changed for EPB 12 / EPB 24 / EPB 48 from version 6.50; in versions below 6.50 they are fixed in the controller software.

Defines the behaviour of the special inputs from the controller. Changing the functions is used if the controller cannot be started up again e.g. due to a defective input.

The following options are available:

External start

If this option is activated, the controller can be started externally via an input (terminal strip); if this is not activated, the **External Start** input is not evaluated.

Delete fault

If this option is activated, the controller can be started externally via an input (terminal strip); if this is not activated, the **Delete External Fault** input is not evaluated.

External flashing

If this option is activated, the controller can be switched to flashing externally via an input; if this is not activated, the **External Flashing** input is not evaluated.

External fault

If this option is activated, the controller can be switched to **Fault** externally via an input; if this is not activated, the **External Fault** input is not evaluated.

System ON

If this option is disabled, the **External On** command is not queried; the system can always be started up even if there is no **ON Command**.

Note:

The **ON command** is fixed as default setting in the controller hardware and is permanently active.

External manual mode

If this option is activated, the controller can be switched to **External Manual Mode** via an input; if this is not activated, the **External Manual** input is not evaluated.

Emergency program

If this option is activated, the controller can be started externally via an input (terminal strip) to the emergency program; if this is not activated, the **External Emergency Program** input is not evaluated.

Key switch clocking

If this option is disabled, the **Clocking** setting of the key switch is no longer queried. It is no longer possible to set the system to clocking mode.

Note:

This function can only be changed for EPB 12 / EPB 24 / EPB 48 from version 6.60.

Check key switch

If this option is disabled, the **Check** setting of the key switch is no longer queried. It is no longer possible to set the system to check mode or bus test.

Note:

This function can only be changed for EPB 12 / EPB 24 / EPB 48 from version 6.60.

6.10.10 Function additional relay PWK 24 / PWK 48

These settings define the behaviour of the additional relays in the power cards of the controller EPB 24 / EPB 48.

Each power card has two relays that are mapped to the addressed signal group.

In basic state, these are always inactive and switch at the defined time according to the setting.

Note:

This function is not yet available.

6.10.10.1 Relay 1 for green / relay 2 for waiting signal

If this setting is chosen, relay 1 switches on when the affected group switches to green and goes off again at the end of green.

Relay 2 switches parallel to the waiting signal (if active) of the affected group.

6.10.10.2 Manual switching

In this setting, the relays can be switched on and off specifically in the intersection time plan editor, twice for each cycle.

Note:

This function is not yet available.

6.10.11 Adjust time according to radio clock

If the system time was changed manually for test purposes, the internal system time is readjusted to the radio clock with the time set in this box.

Notes:

- This function can only be changed for EPB 12 / EPB 24 / EPB 48 from version 6.60.
- This function is not carried out if there is no connection to a radio clock type V4.

6.10.12 LED Panel

The ON-time of the LED panel (signal group display) can be adjusted here. The display goes off after the adjusted time.

As soon as a key on the keyboard is pressed or the display is switched on again, the LED panel is switched on again.

Note:

This function is only available for EPB 48 / 12 from version 6.6x. It is not available for EPB 24.

6.10.13 Special functions: sync. points

This option can be used to change the functionality separately for each sync. point. The program can be spread out for a fixed time by using a sync. input. When activated, the functionality changes as follows:

the system no longer waits in the respective sync. point but continues when the respective sync. input is not active. An existing sync. delay is carried out. If the respective sync. input is activated (pulse or continuous), the entered continue time always runs as a fixed feature on reaching the respective sync. point.

Notes:

- This function is only available for EPB 12 / EPB 24 / EPB 48 from version 6.7x.
- The function is only carried out in the modes enabled in the mask
Function Sync. Inputs: ☞ 6.8.1
- Only the sync. inputs of the terminals are evaluated.
The sync. inputs of the DCF clock or radio clock are not evaluated.
- Existing offset times for progressive signalling are not taken into account.

6.10.14 External programs

This function can be used to switch the controller via fixed inputs or optional detector inputs to **External programs**.

Note:

Inputs 22 and 23 are not wired by default: if necessary, they have to be connected to the spare terminals or similar.

The controller then switches immediately to **External programs** when one of the inputs for switching the function on is activated (pulse or continuous). As soon as one of the inputs for switching the function off is activated (pulse or continuous), the controller switches back to the last active mode. If no input has been selected for switching the function off, the controller only remains in the external program mode for as long as the input is active (continuously).

Manual, clock mode and radio clock are not carried out when this function is enabled. However, the following modes take priority:

- Flashing
- Manual
- Emergency program

Note:

This function is only available from version 6.80.

6.10.14.1 External programs mode: contact control

From CPU version 7.00, the external programs mode can be carried out with contact control. For contact control to be carried out, no clear-down function (input 23 or adjusted detector input) may be present in the respective program.

How it works:

As soon as input 23 or the defined detector input (that triggers the external programs mode) is triggered, the external programs mode remains active until there is no longer any signal at these inputs.

6.10.14.2 External programs mode: end automatically

From CPU version 7.00, the external programs mode can be ended automatically with a fixed timeout. To activate this function, enter the required time in the corresponding boxes. The maximum time range is 24 hours, 59 minutes and 59 seconds.

How it works:

The timeout starts as soon as the external programs mode has been activated. At the end of the adjusted time, the external programs mode ends and the controller changes to the currently active mode.

Note:

If the timeout has expired and there is still an active input that switches the external program modes on, this is not switched on again. The external programs mode can only be switched on again when there is no longer any signal at these inputs.

7. CPU simulation

7.1 Simulation function

Once a program has been created, it can be checked on the PC in conjunction with a CPU (CPU with adjusted simulation software).

The simulation software version always corresponds to the respective control software on the controller.

No power cards are actuated via the data base: they are simulated from the PC via the serial interface.

Note:

This function is only available for EPB 12 / EPB 24 / EPB 48 from version 6.50. It is not available for older versions or other controller types.

7.1.1 Simulation query

On selecting **CPU simulation**, the following query asks which program is to be simulated:

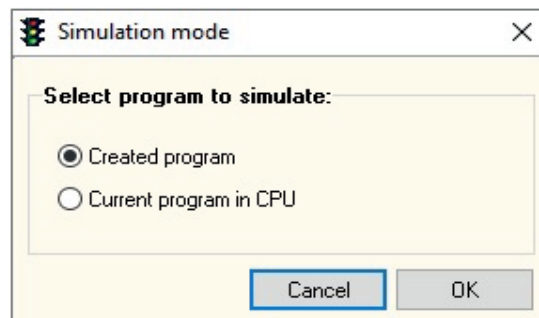

Note:

OK and the selection boxes are only enabled when there is a connection to the simulation CPU with the correct controller type and version.

If there is no connection or the controller type / version are not right, a corresponding error message appears.

7.1.1.1 Simulate created program

On selecting this option (default), the program data of the currently active program are transferred by Ampeltools to the CPU.

It is the same procedure as for **Export data to controller**. Once data transfer is completed, the simulation interface opens automatically.

7.1.1.2 Simulate current program

On selecting this option, the simulation interface opens immediately. The program is then simulated with the program data in the CPU.

7.1.2 Simulation window

The simulation window depicts the display and keyboard of the connected CPU. Below the display, a signal group panel appears showing the status of the existing signal groups in the course of the program.

Note:

If there is no connection to the CPU, all signal group panels are off. A corresponding message appears in the display.

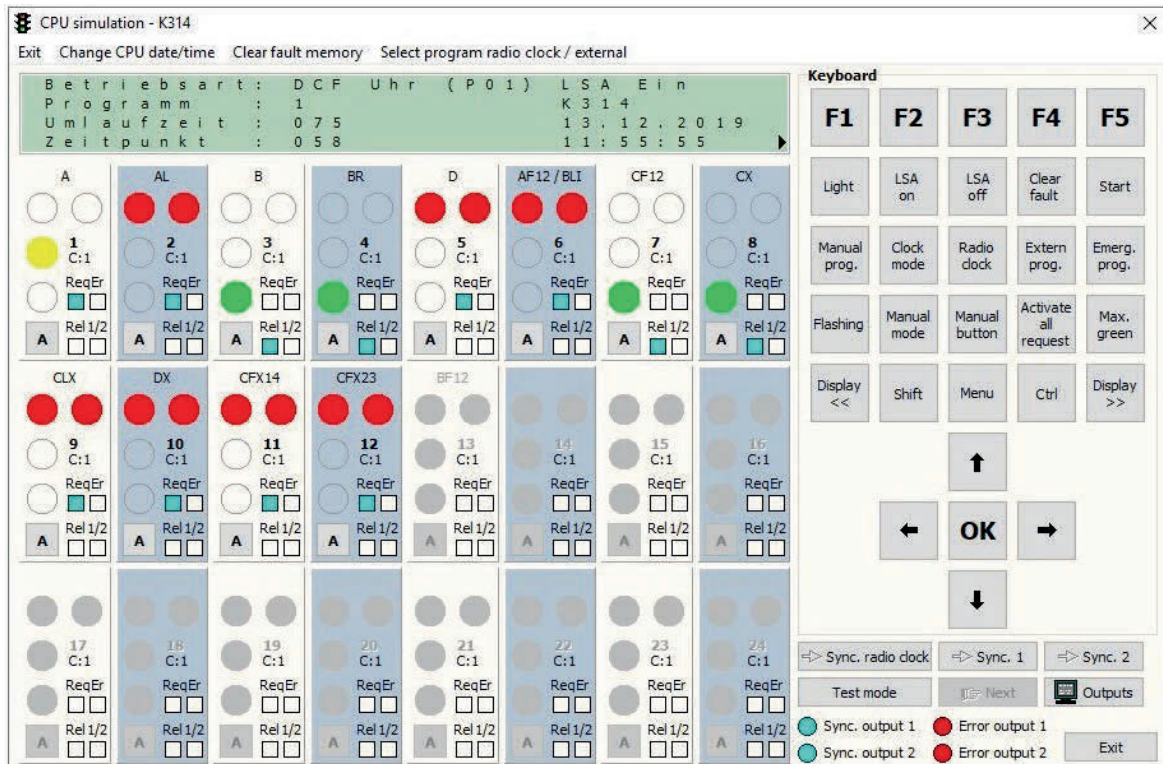

Click on **Outputs** to open the mask **Show outputs**.  4.2.9

7.1.3 Simulate program

All programs can be simulated in the fixed time mode with VA from version 6.50. The adjusted version must always match the controller software (CPU update may be necessary).

Note:

Support for the **Ampelwin** software is no longer provided from CPU version 7.1x. It is then no longer possible to simulate programs of the **VA mode**.

7.1.3.1 Basic operation

All functions are carried out using the depicted keyboard. The CPU displays appear in the depicted display. The keyboard is operated according to the specific controller.

7.1.3.2 Check program

All basic information such as program, cycle time, time etc. are shown in the display. A signal head is shown for every active group; this is disabled for inactive groups. The program is checked according to the corresponding panels.

Structure of the signal group panel:

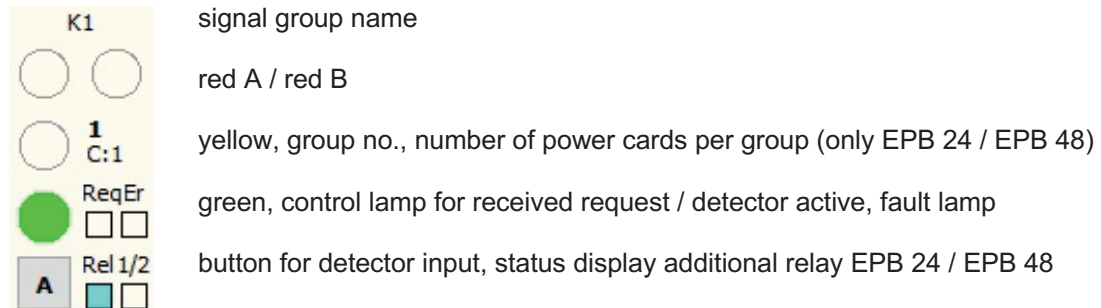

The signal head lamps red A, red B, yellow and green show the signal panel for the respective group.

The number following **K** shows the number of power cards (only EPB 24 / EPB 48) mapped to the respective group. EPB 12 always only has one power card per group.

The **Req** lamp is always turquoise when the detector input of the respective group is confirmed or a request has been received for this group.

The **Er** lamp is always red when there is an error in the respective group.

The **Rel. 1 / 2** lamps are always turquoise when the respective additional relay has switched on (only EPB 24 / EPB 48).

A is used to simulate the detector input of the affected group. Press together with **Shift** to lock the function: the text changes to **CO** for continuous use. Click on **CO** to switch the function off.

7.1.3.3 Progressive signalling / additional displays

In addition to the signal head panels, other functions are also available for simulation.

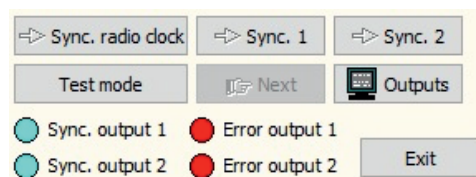

Use **Sync. radio clock**, **Sync. 1** and **Sync. 2** to simulate the corresponding sync. inputs for progressive signalling.

Test mode switches the test mode on and enables the **Next** button. This function is used to move the program on second by second for testing.

Sync. output 1 / 2 and **Error output 1 / 2** show the status of the respective relays. The lamps are white when the respective relay is inactive. **Sync. output 1 / 2** is turquoise and **Error output 1 / 2** is red when the respective relay has switched on.

7.1.3.4 Check signal safeguarding

The simulation interface can be used to check the programmed signal safeguarding. It is not possible to produce interim time and min release time errors by hand: these are ascertained and evaluated by the CPU. All other errors can be produced via the simulation interface. The CPU then triggers depending on the programmed signal safeguarding. The corresponding error appears in the display.

7.1.3.4.1 Start simulation after fault

If a fault was generated that caused the simulation to switch off, the fault must be eliminated on the respective signal head panel, firstly by pressing **Clear fault** on the keyboard.

If there are no further faults, the display shows **Start**.

The simulation can now be started again by pressing **Start**.

Any other faults are shown in the display. It is not possible to start when faults are present: they have to be eliminated first.

Note:

If the function **Start deletes all errors**  2.8.2.2 was activated in the program settings (sub-point: CPU simulation /emergency controller), pressing **Start** deletes all generated faults and clears the error in the display. Simulation then starts again automatically: **Start** is disabled until the simulation has been started again.

7.1.3.4.2 Lamps defective

To simulate a fault in the lamps, simply click the left mouse button on the required colour for the respective signal group. **X** appears for the chosen colour.

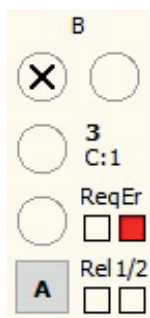

If a lamp defect has been triggered and the corresponding channel is monitored for defective lamps, the simulation CPU triggers and a corresponding error message appears in the display.

7.1.3.4.3 Interlocking matrix

To simulate a green / green error, simply click the right mouse button in green for the respective signal group.

If the hostile signal group has green, **X** appears at the chosen colour.

Alternatively, the error is also generated by clicking the left mouse button on green while holding the shift button.

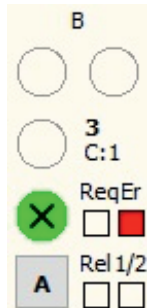

The simulation CPU triggers according to the programmed signal safeguarding. A corresponding error message appears in the display.

7.1.3.4.4 Status error

To trigger a status error, simply click the right mouse button on the required colour for the respective signal group. **X** appears for the chosen colour.

Alternatively, the error is also generated by clicking the left mouse button on the respective colour while holding the shift button.

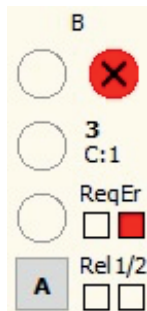

The CPU then triggers depending on the programmed signal safeguarding. A corresponding error message appears in the display.

7.1.3.4.5 Red / green error

To trigger a red / green error, simply click the right mouse button on the required colour for the respective signal group. **X** appears for the chosen colour.

Alternatively, the error is also generated by clicking the left mouse button on the respective colour while holding the shift button.



Note:

A red / green error is only triggered if status monitoring for red and green is disabled for the affected group, or if the interlocking matrix has not already triggered beforehand.

7.1.3.5 Change CPU date / time

Select **Change CPU date / time** to open the following mask for changing the date and time of the simulation CPU to test the programmed weekly automatic function.

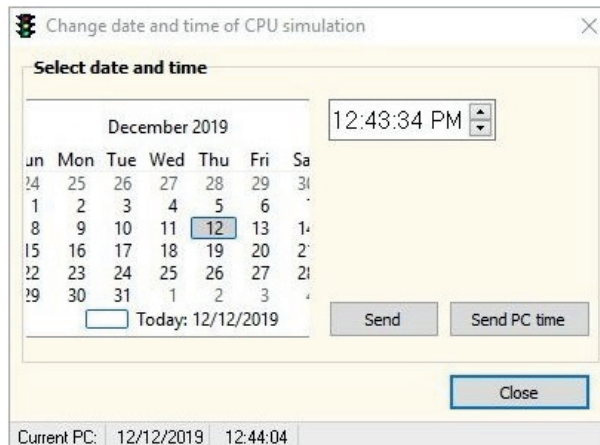

The current date and time are always preset when the mask is opened. Use the calendar function to select the required date (today's date is marked in colour). There is an input box for selecting the time.

Send sends the adjusted date and time to the simulation CPU.

Send PC time sends the current date and time from the connected PC to the simulation CPU.

Note:

Clock mode must be selected to test the weekly automatic.

7.1.3.6 Clear error memory

Use **Clear error memory** to clear the error memory. When selected, the following query appears:

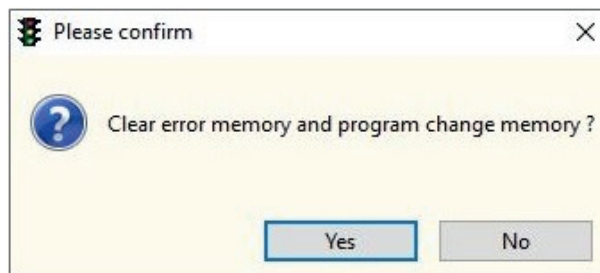

Yes clears the error and program change memory.

7.1.3.7 Select program radio clock / external

Select program radio clock / external is enabled in the **Radio clock** and **external** modes.

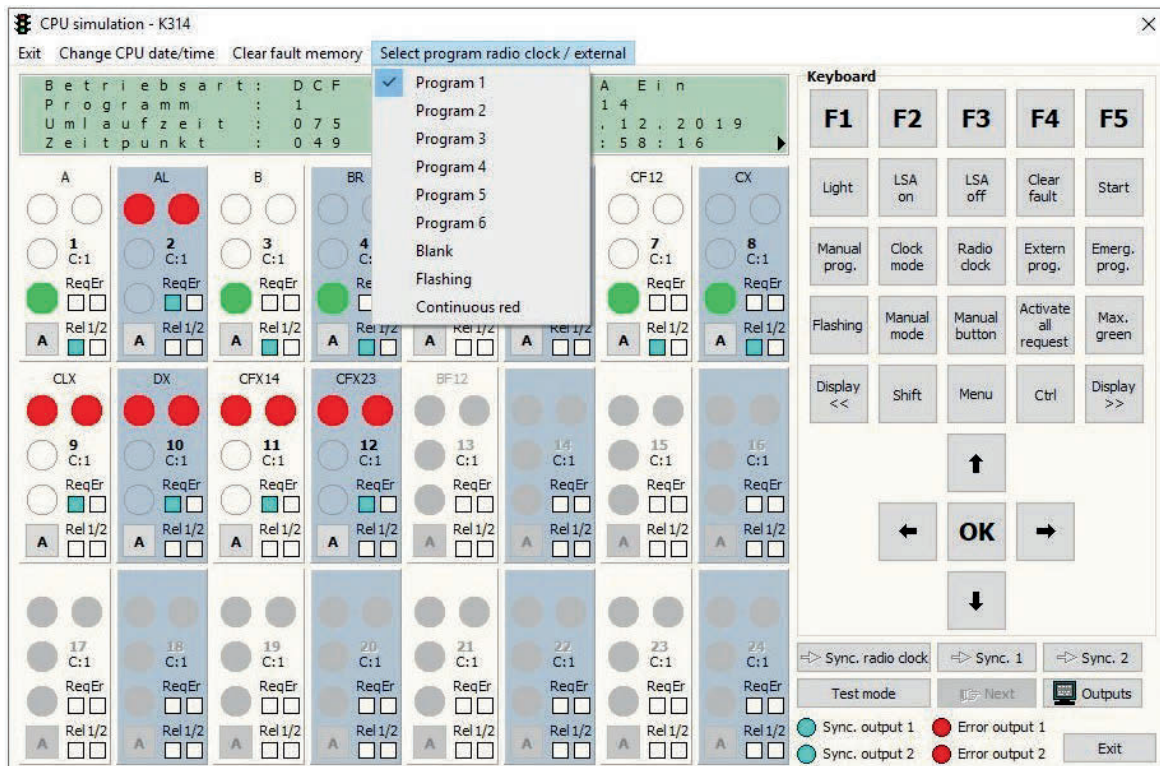

This function selects the program to be changed to in the radio clock or external mode.

Note:

Manual program selection is done at the keyboard, as in the controller.
On selecting **clock mode**, the program is changed by the internal switching points of the weekly automatic.

8. CPU protocol

8.1 Protocol

This function is used for writing and graphic display of a protocol from the controller. Select **Protocol** under CPU protocol to see the following window:



8.1.1 Write protocol

Enter the controller whose protocol is to be written in **Device type** (Print Act.). Different baud rates can be adjusted for the printer interface in some controller types: please select the right one for the protocol. If the wrong baud rate is adjusted, a corresponding message appears and the data transfer is cancelled. For controllers with separate controller and printer interface (all EPB types), Print Act. can be activated by pressing **Start**. Press **Stop** stops active printing.

Note:

Start and **Stop** are disabled if no valid controller interface is present or if a controller type has been adjusted that only has one interface e.g. MPBxx / FG 2 etc. In this case, Print Act. must be switched on manually at the corresponding controller.

8.1.2 Data flow control

If Print Act. is active at the controller, the received print data are displayed there. The content scrolls upwards as soon as the reception window is filled with data. **Reception** lights up green as soon as valid print data are received.

8.1.3 Display graphical data during transfer

If valid Print Act. data have been received and **Display graphical data during transfer** is enabled, the currently recorded protocol data are displayed graphically in real time.



Note:

This window closes automatically as soon as **CPU protocol** is closed.

8.1.4 Save protocol

If **CPU protocol** is closed and valid data are present, a dialogue appears for saving the protocol. Enter the name for the protocol in **File name**. **Save** saves the current protocol.

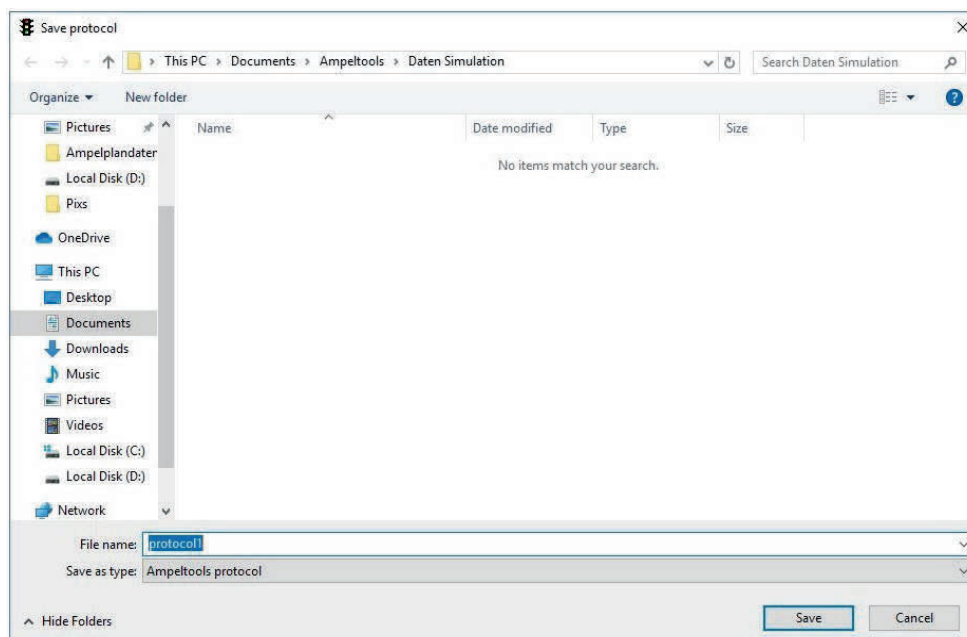

This file can be opened again later for analysis. 8.2

8.2 Analyse protocol

To analyse a saved protocol, select **Analyse** in the menu structure (CPU protocol). A dialogue appears showing all saved protocols.

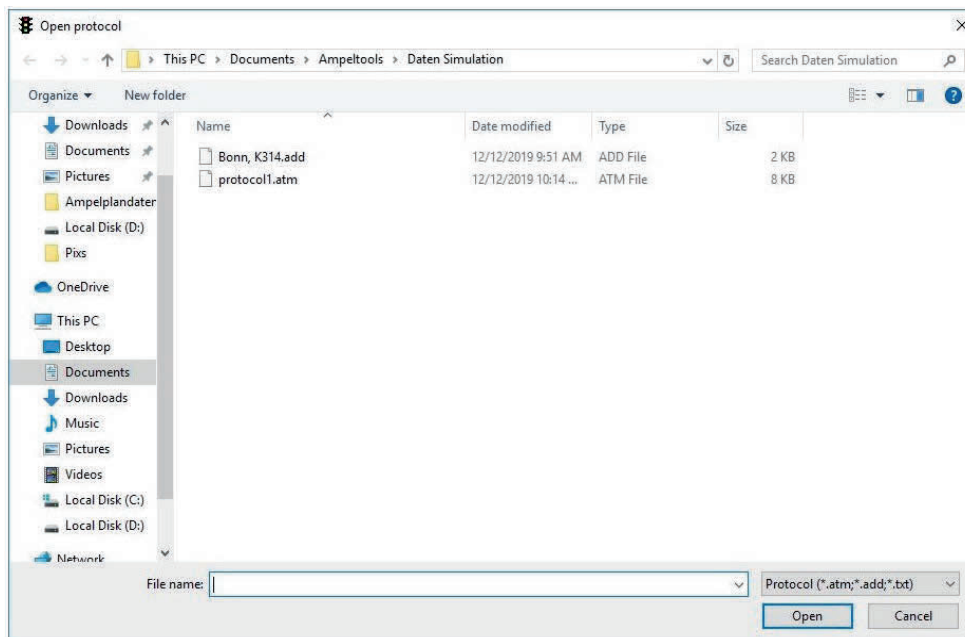

Select the required file with the left mouse button and confirm by pressing **Open**. The marked file is opened and the data are shown in the analysis window. If the protocol does not fit in the analysis window, vertical and horizontal scroll bars appear.



The analysis shows the signal group names for each group, the expired green phases and also the duration of the red-yellow and yellow phases, depending on the settings. At the end of each cycle, a dividing line appears with time details for the duration of the last cycle.

8.2.1 Selection menu analysis window

The analysis window has various functions that are selected in a menu.

8.2.2.1 File

This menu features the general functions of the analysis window.

Load data

Click here to open a dialogue for loading existing protocols. The function is the same as when selecting the analysis function in the menu structure. ☞ 9.2

Note:

It is only possible to show one protocol file at any one time. If another protocol is loaded, the data in the analysis window are updated accordingly.

Save marked area

This function is used to save a marked area in the analysis window. A corresponding dialogue appears.

Close

This closes the analysis window.

8.2.2.2 Print

This menu features the print functions of the analysis window. Maximum 120 seconds are printed on a page.

The print output (colour or black-and-white, with red-yellow / yellow phases etc.) is adjusted in the print settings. ☞ 2.3

All

Prints the entire content of the analysis window.

Marked area

Prints the marked area of the analysis window.

Note:

Depending on the printer settings, a dialogue for selecting the printer appears when you click on a print function. If this is disabled, the printout is done immediately on the adjusted standard printer.

8.2.2.3 Seconds display

This function is used to define how the seconds ruler is to be shown above the graphic display.

As intersection time plan

This setting always shows the seconds as in the intersection time plan.

At the end of the cycle, the display begins again at second 0.

The duration of the last cycle appears in brackets after the Tc text.

Continuous

The seconds display is continuous with this setting. The display always begins with second 0 and counts continuously up to a maximum duration of 3600 seconds.

The duration of the last cycle appears in brackets after the Tc text.

8.2.2.4 View

Various different view functions can be adjusted here.

Zoom

Opens the selection menu for adjusting the view size of the protocol.

Some zoom values can be chosen directly. Use **+** and **-** on the keyboard for variable adjustment of the zoom range. Alternatively, the zoom range can be adjusted with the mouse scroll wheel together with **CTRL**. The zoom range can be adjusted between 20 - 500 %. The current setting appears bottom left in the analysis window.

Automatic scrolling

If an active protocol is on display in the analysis window, here it is possible to adjust the reaction at the end of the window. The following settings are possible:

- **on:** the current protocol (intersection time plan) runs continuously to the left and the vertical scroll bar always remains at the right end of the analysis window. Move the vertical scroll bar with the mouse to view the area moved out of the window to the left.
- **off:** on reaching the right edge, the current protocol (intersection time plan) stops where it is and the vertical scroll bar moves automatically to the left. Move the vertical scroll bar with the mouse to view the area moved out of the window to the right.

Red-yellow and yellow phases

The duration of the red-yellow and yellow-phases are shown in the protocol analysis according to the settings.

Red phases

The duration of the red phases are shown in the protocol analysis according to the settings.

Show all standard

All display functions are set to standard.

8.2.3 Measuring function

An area can be marked within the analysis window. To do so, click the left mouse button at the position where the marking should begin. Holding the mouse button, mark the area by moving the mouse across to the required end point, then let go. The corresponding area is then marked in colour.

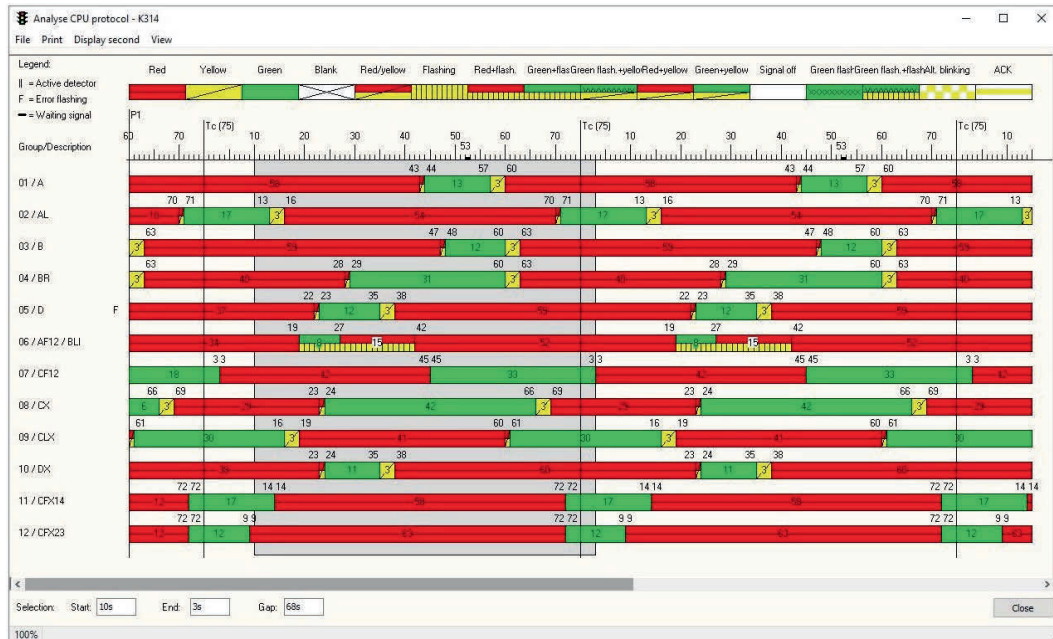

The start and end position together with the marking time appear bottom left in the analysis window.

Press **Esc** to cancel the marking again.

If marking has been applied, it can be extended at the start or end point: a corresponding symbol appears. The marked area can then be extended to the left or right; shifting the area is not possible.

Use **Save marked area** to save this area as a separate protocol file; it can be printed in the Print menu (marked area).

Note:

It is always only possible to mark one area. If marking has already been applied, it is deleted again as soon as you start to mark a new area with the left mouse button.

8.2.4 Display with green phase extension

A green phase extension is shown in the analysis as follows:

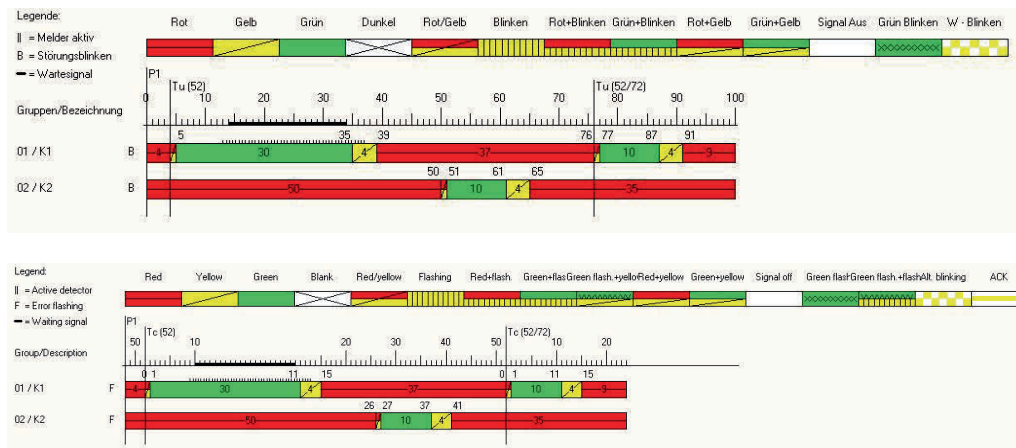

A black bar appears in the second being extended. This then appears spread out. The second in which the extension occurs is shown in the seconds ruler.

At the dividing line which appears when a cycle ends, the **Tc** text is followed by the duration of the last cycle (min / max).

The example shows the extension in the 10th second.

8.2.5 Display with continue time (progressive signalling)

The analysis shows the course of the continue time (progressive signalling) as follows:

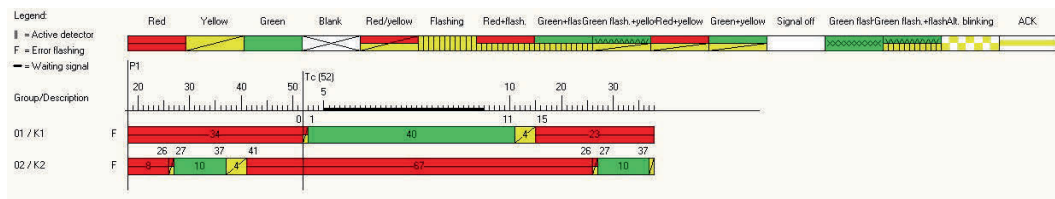

A black bar appears in the second in which the continue time is running. This then appears spread out. The seconds ruler shows the seconds in which the sync. delay takes place, waiting for the progressive signalling pulse. At the dividing line which appears when a cycle ends, the **Tc** is followed by the duration of the last cycle (min / max). The example shows the sync. delay in the 2nd second and the sync. point in the 5th second.

8.2.6 Display with jump (group on request)

If a jump is carried out within the analysis, this is shown as follows:

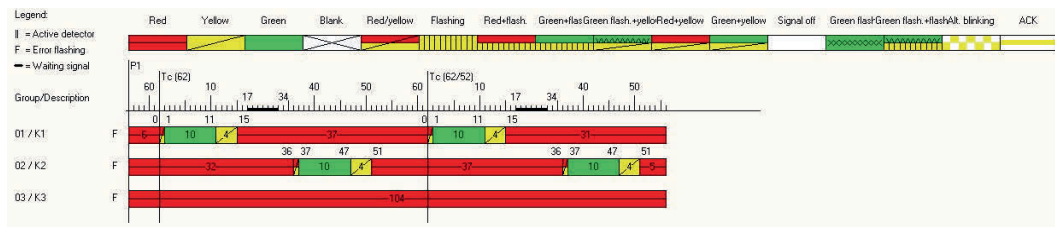

A black bar appears in the second in which the interim times are still running. This then appears spread out before a jump is carried out. The seconds ruler shows the seconds from which second is jumped to which second. These values correspond to the entries of **Request query** and **Target** in the intersection time plan. At the dividing line which appears when a cycle ends, the **Tc** is followed by the duration of the last cycle (min / max). The example shows the jump from the 17th second to the 34th second.

8.3 Printing data from controller

This function is used to record, save and, if necessary, print all printouts from all controllers with print function. Select **Printing data from controller** under CPU protocol to see the following window:

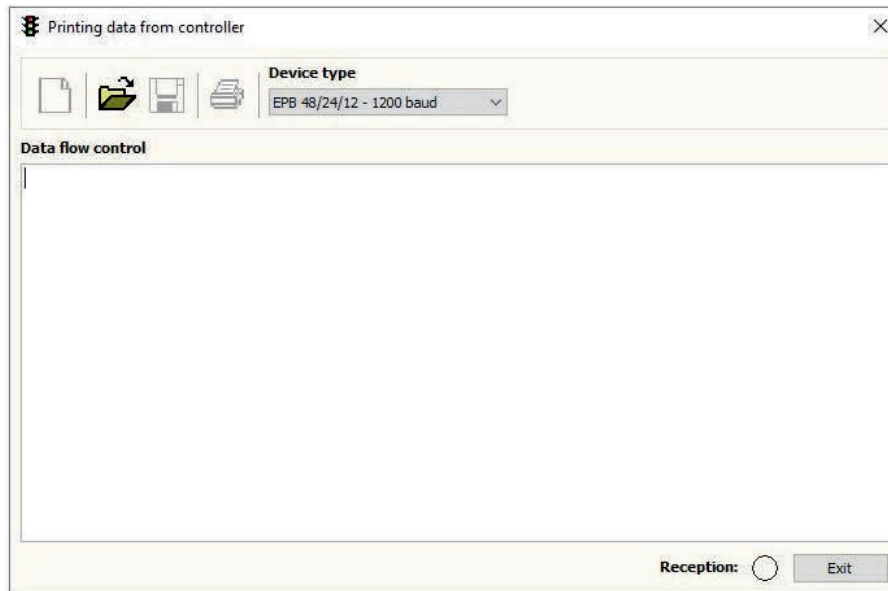

Note:

The analysis window can be adjusted in height, but will open in the default size again after the next program start.

8.3.1 Record print data

The **Device type** is selected as the controller from which a protocol is to be recorded. 1200 baud is the default baud rate for all controllers. The baud rate can be adjusted in the system functions for controllers EPB 12 / EPB 24 / EPB 48.

If the wrong baud rate is adjusted, a corresponding message appears and the data transfer is cancelled.

If a print is currently in progress at the controller, the received print data are displayed there. The contents scroll upwards as soon as the reception window is filled with data. **Reception** lights up green as soon as valid print data are received.

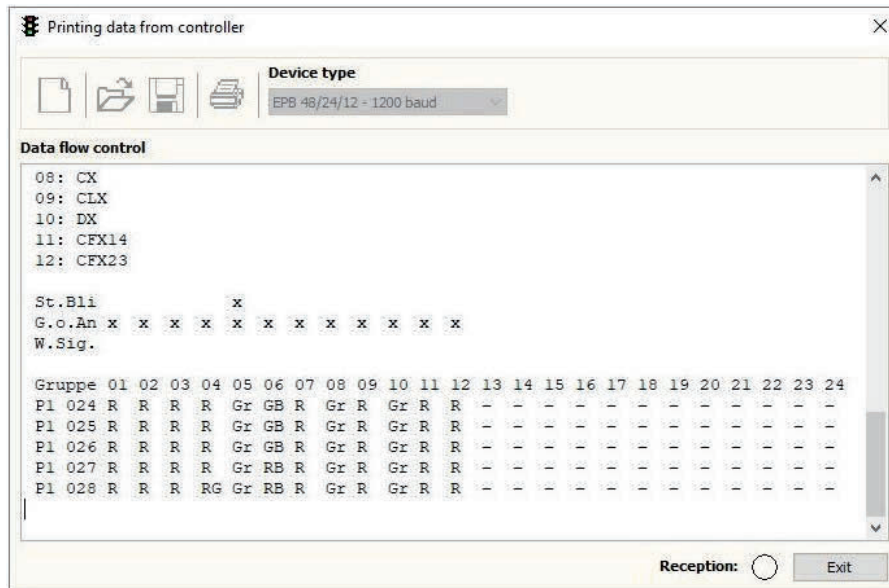

8.3.2 Save print data

If **Printing data from controller** is closed and valid data are present, a dialogue appears for saving the data. **Yes** opens the following dialogue:

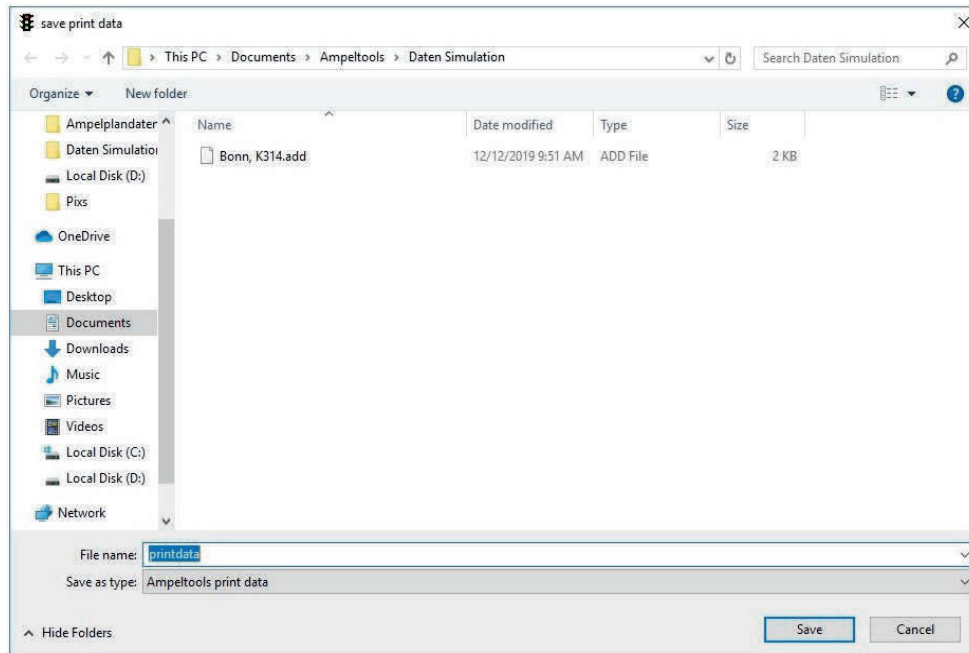

Enter the name for the protocol in **File name**. **Save** saves the current protocol. Alternatively, press **Save print data** to save the current print data.

8.3.3 Use print data

Select **Load print data** to open the following dialogue for loading saved documents:

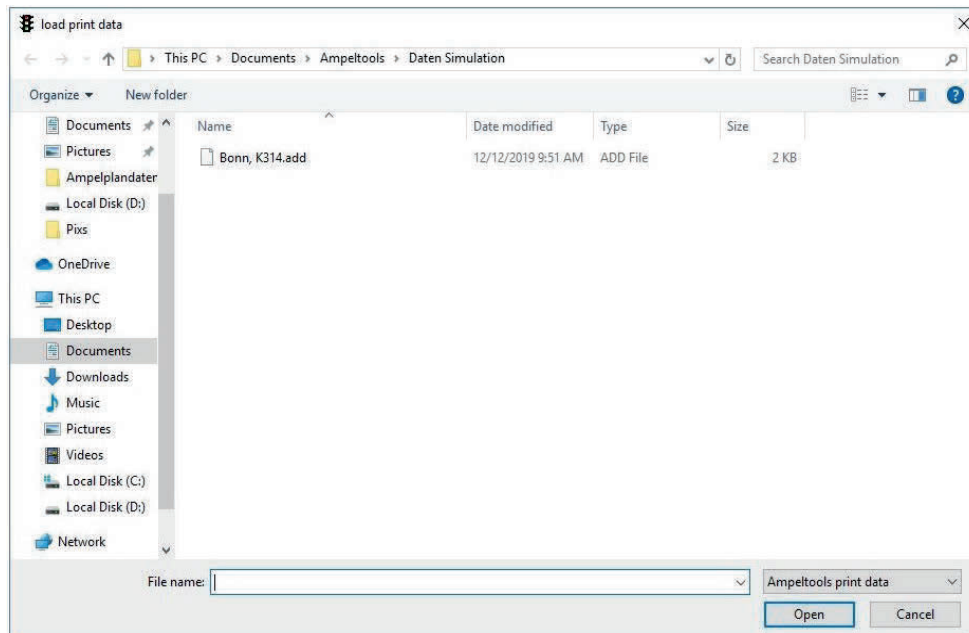

Press **Open** to load a marked file: the corresponding data appear in the window. Press **Print data** to produce a printout of the window contents on the adjusted standard printer. If you select **New**, the window contents are deleted after confirming a corresponding query.

9. Check signal safeguarding

9.1.1 Check signal safeguarding

This function checks signal safeguarding in controller types EPB 12 / EPB 24 / EPB 48. The window header shows the interface being used and the current signal safeguarding protocol number from the CPU.

Next to the **Active check function**, the current program name appears together with the location data deposited in the controller.

The system status is polled by the controller when this function is selected. If there is no connection to the controller (wrong system type, version, interface, etc.), a corresponding error message appears. To check signal safeguarding, the controller first has to be turned off with **TLS Off**. A corresponding message appears if this condition is not fulfilled:

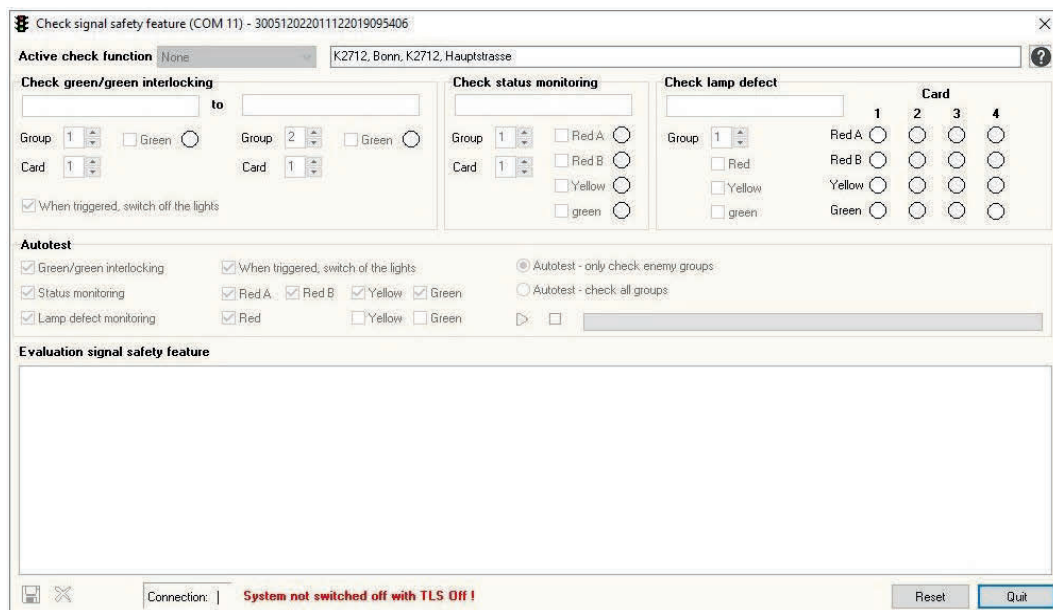

Note:

The displayed protocol number is generated automatically by signal safeguarding and refers to the current supply for signal safeguarding. The number is mapped uniquely to the performed signal safeguarding test.

The protocol number changes automatically with every change to the signal safeguarding. The signal safeguarding then has to be checked again as the number on the documentation no longer corresponds to the current signal safeguarding protocol number.

If the controller was turned off with **TLS Off**, the system checks whether the key switch on the controller is set to Clacking. Otherwise a corresponding message appears.

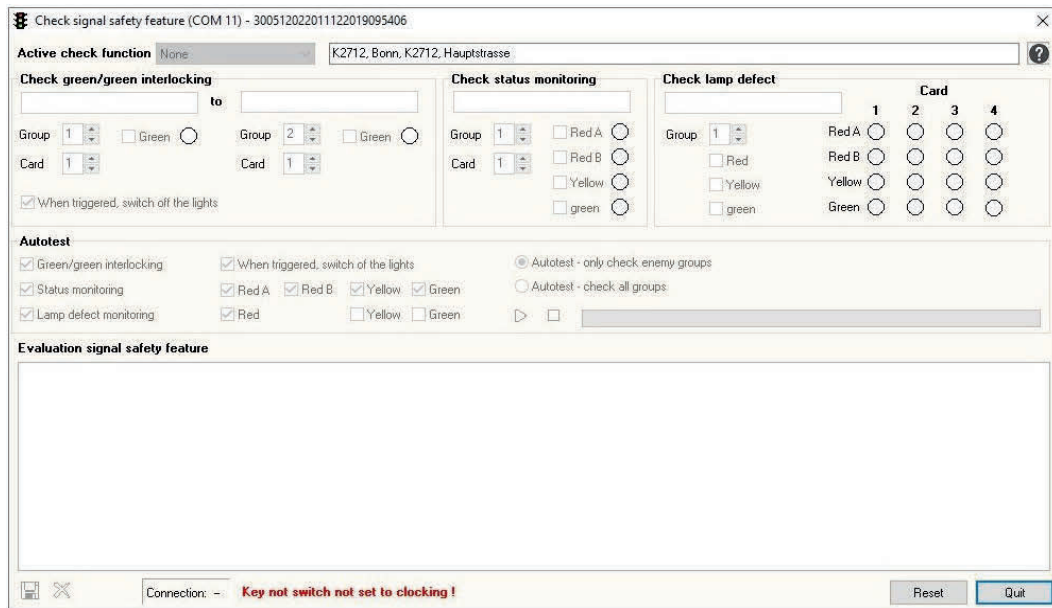

If the controller was turned off with **TLS Off** and the key switch is already set to **Clacking**, a corresponding message appears.

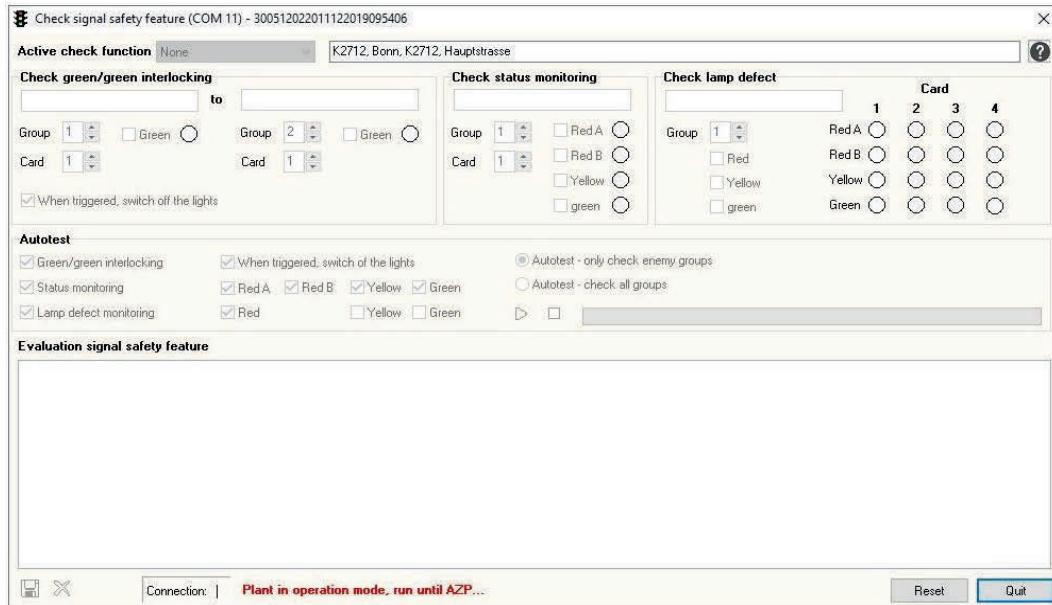

If all conditions are fulfilled, the selection box **Active check function** is enabled and all other selection possibilities are disabled.

The only functions that are enabled are for saving a protocol file.

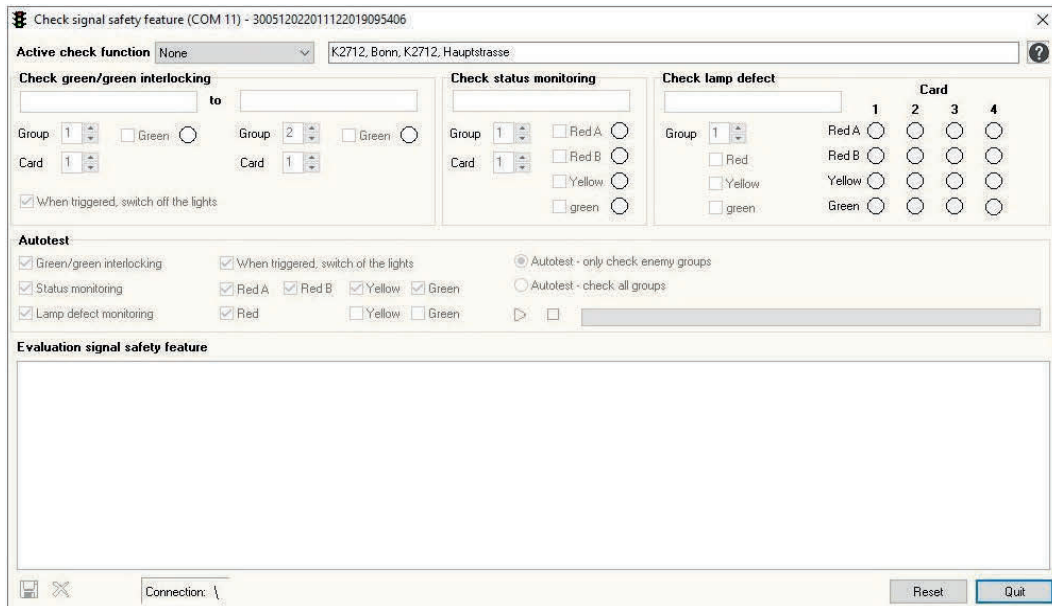

The check function entered in the box activates the corresponding check function.

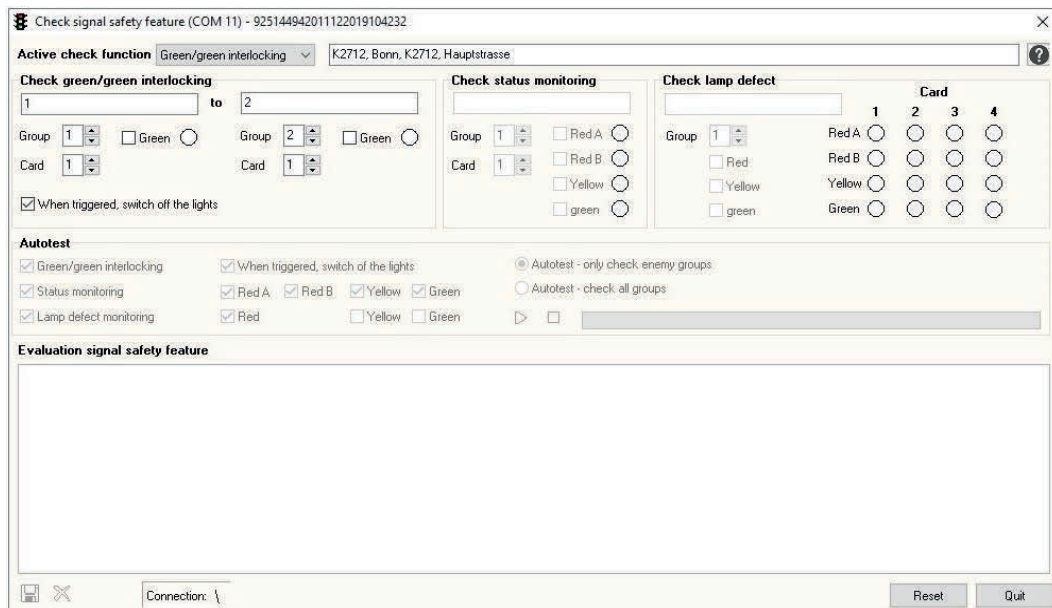

Note:

A test can also be carried out at a simulation CPU. However, here it is only possible to check the supply and function of signal safeguarding. No power cards or lamps are available in the simulation so that an additional test is necessary with corresponding hardware (controller, power cards, lamps etc.).

After testing at a simulation CPU, **Simulation** is stated on the protocol printout or on the printout from the operating logbook. This makes it quite clear that the test only referred to a check on a simulation CPU without connected hardware.

A check is not possible if the **Check signal safeguarding** window is opened and a triggering error is already present (card error, 42V failure, measuring fault etc.). A corresponding error message appears.

If this message is confirmed, **Check signal safeguarding** is closed. A test can only be carried out after all triggering errors have been eliminated.

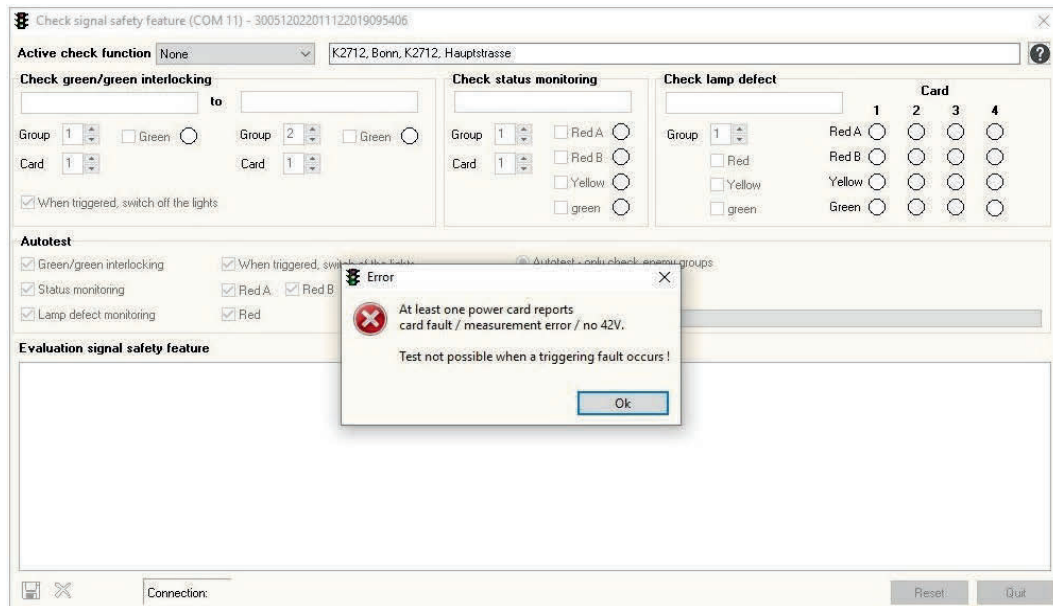

If a power card with active filament measurement (light bulbs) is detected in the current supply, the following message appears.

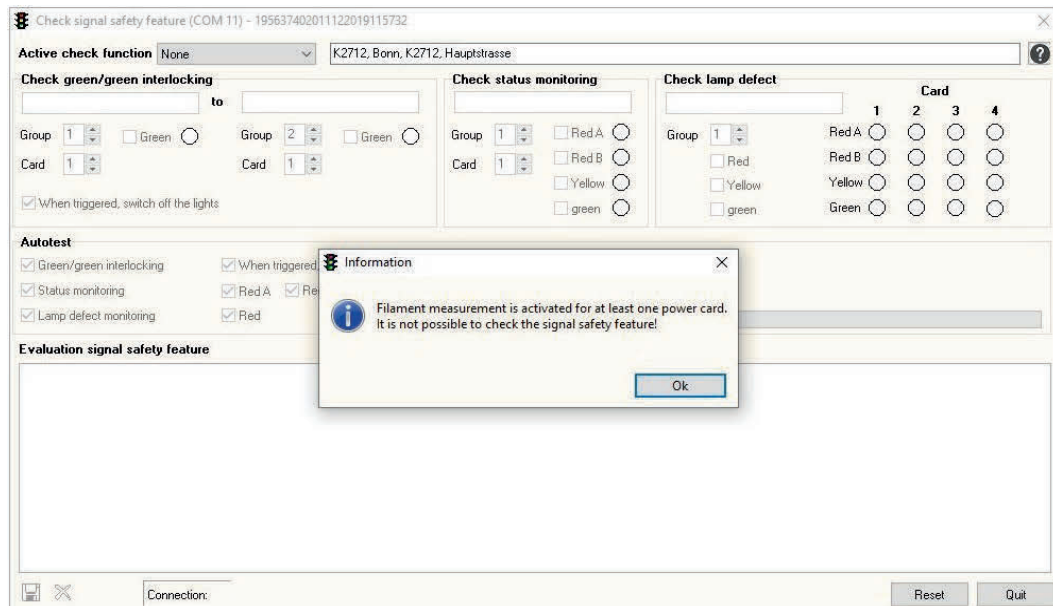

On confirming the message, the **Check signal safeguarding** window is closed as a check is only possible when LED measurement is switched on.

Note:

To perform the test on a lamps board (test board), one filament lamp (max. 40 W) can be connected to each channel when LED measurement is switched on.

Checking is also not possible if a data bus error occurs during the test. A corresponding message appears.

If the data bus error is quit on the controller, the **Check signal safeguarding** window is closed due to CPU restart.

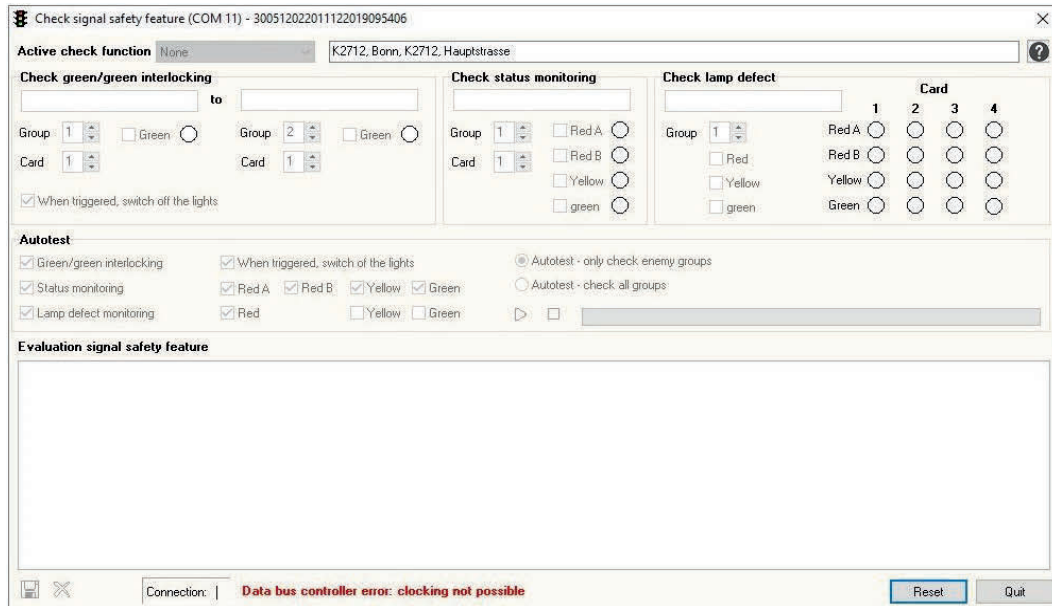

Every test result (feedback whether signal safeguarding is triggered or not) of the current check is entered in **Evaluation signal safeguarding**.

The contents of the results list can be saved in a file as documentation, printed and loaded from the file again.

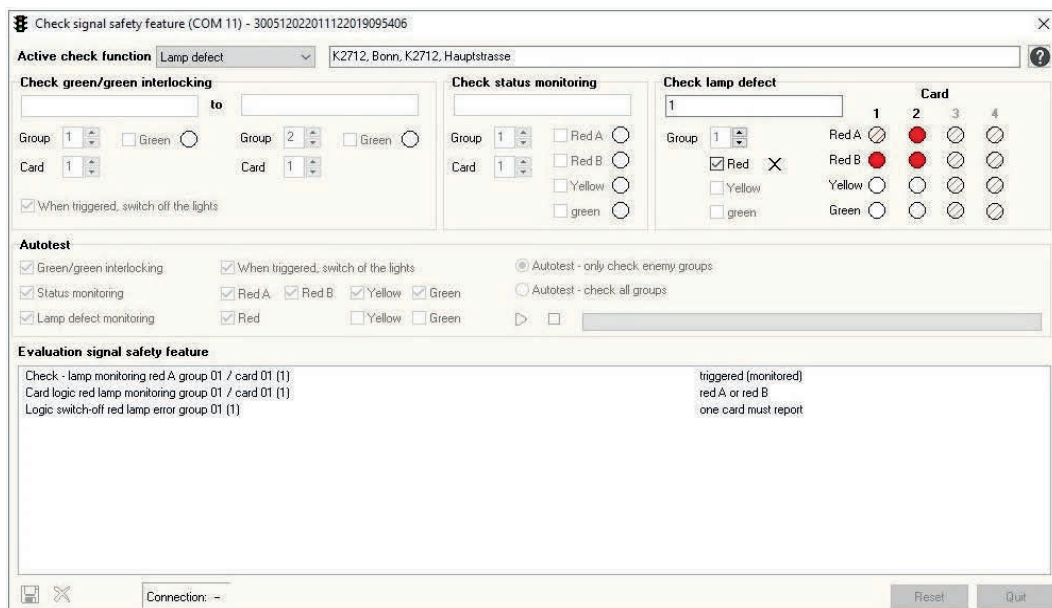

The test results are also sent to the operating logbook. This function can be deactivated in the system functions.

9.1.2 Legend feedback symbols

Click on  to open a window with explanations for the feedback symbols appearing in the individual test functions.

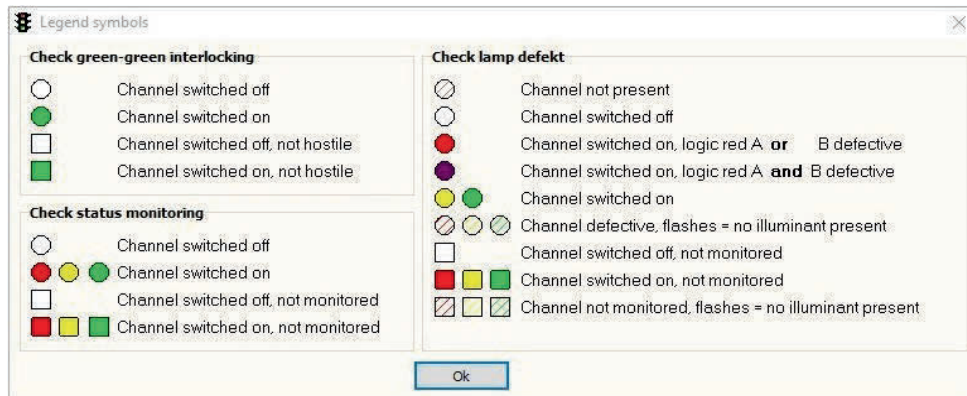

Note:

This window closes automatically if another test function is chosen in the selection box or if the **Check signal safeguarding** mask is closed.

9.1.2.1 Check green-green interlocking

1. Feedback lamp round, white:
Channel present, not switched on
2. Feedback lamp round, green:
The green lamp of the chosen signal group / power card is switched on.
3. Feedback lamp square, white:
The green lamp of the chosen signal group / power card is switched off and not hostile to the other switched on green lamp.
4. Feedback lamp square, green:
Both green lamps of the chosen signal groups / power cards are switched on and not hostile to each other.

9.1.2.2 Check status monitoring

1. Feedback lamp round, white:
Channel present, not switched on
2. Feedback lamp round, red, yellow, green:
The respective lamp of the chosen signal group / power card is switched on.
3. Feedback lamp square, white:
The respective lamp of the chosen signal group / power card is switched off and not monitored.
4. Feedback lamp square, red, yellow, green:
The respective lamp of the chosen signal group / power card is switched on and not monitored.

9.1.2.3 Check lamp defect

1. Feedback lamp round, cross-hatched:
Channel not present. This symbol appears when power cards are not present.
2. Feedback lamp round, white:
Channel present, not switched on
3. Feedback lamp round, red:
All red lamps of this power card are switched on, logic = **OR** monitored.
4. Feedback lamp round, purple:
All red lamps of this power card are switched on, logic = **AND** monitored.
5. Feedback lamp round, yellow or green:
All yellow or green lamps of this power card are switched on.
6. Feedback lamp round, cross-hatched:
Channel defective (active monitoring test)
If this feedback lamp flashes, there is no lamp present.
7. Feedback lamp square, white:
Channel switched off, not monitored
8. Feedback lamp square, coloured:
Channel switched on, not monitored
9. Feedback lamp square, cross-hatched:
Channel defective (active monitoring test), not monitored
If this feedback lamp flashes, there is no lamp present.

9.1.3 Check green/green interlocking

This function is used to check individual green/green interlocking.

This is done with **Check green/green interlocking**. To do so, select **Green/green interlocking** in the **Active check function**.

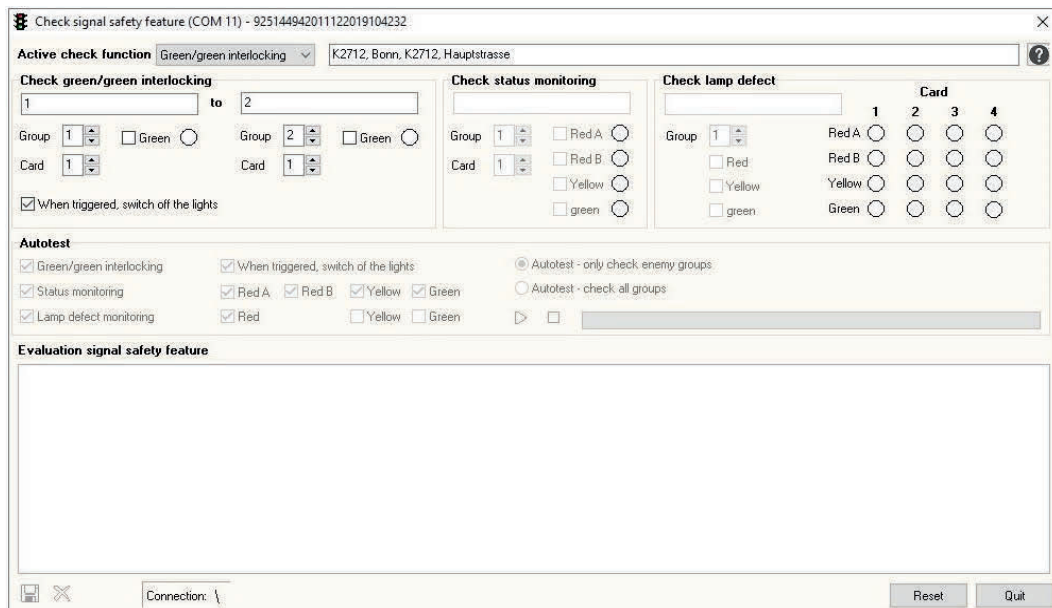

Generally, all feedback lamps are shown as a white circle (channel not switched on). If the feedback symbol appears as a square, the two chosen signal groups are not hostile to each other.

If green of a signal group is on, the feedback lamp to the right of it lights up as soon as the green output of the corresponding power card is switched on (active feedback).

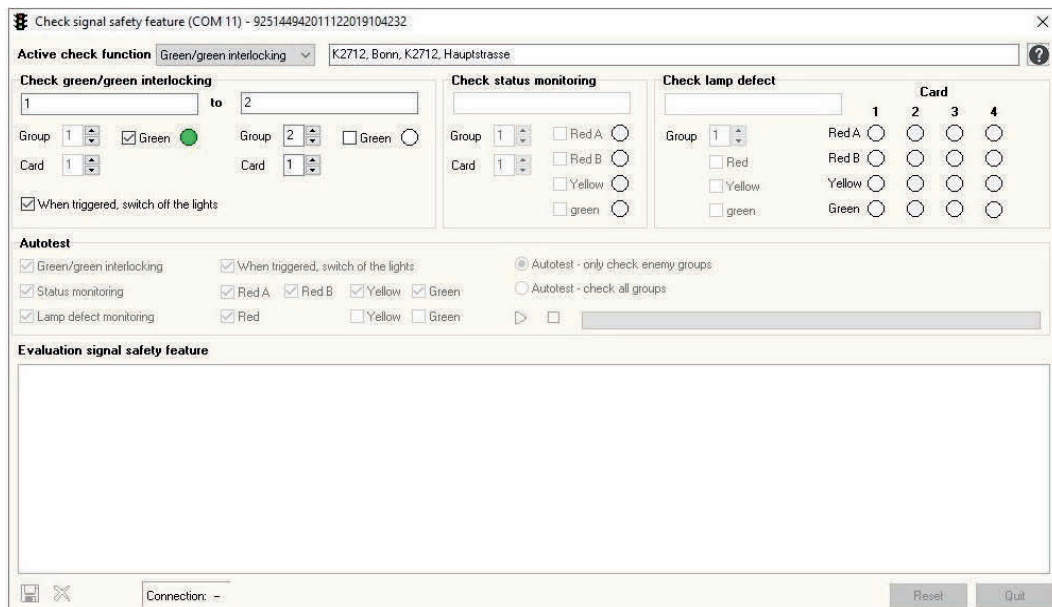

Notes:

- It is not possible to select the card for controller type EPB 12!
- It is not possible to select the same group in the selection boxes for **Group**: in this case the green lamps are not switched on or off in case a green lamp is already on.

- As soon as a green of the selection boxes on the right has been switched on, selection of the left selection boxes is disabled.

In the left selection boxes, choose the required signal group in **Group / card** against which you want to check green interlocking. If you tick **Green** to the right, the green of the selected signal group is switched on.

In the right selection boxes, in **Group / Card** you should select the signal group against which the signal group that is already switched on should be checked. The green for this signal group is also switched on by ticking **Green** to the right.

Note:

If the green lamp is switched on for the signal group / card adjusted on the left, the selection boxes here are disabled.

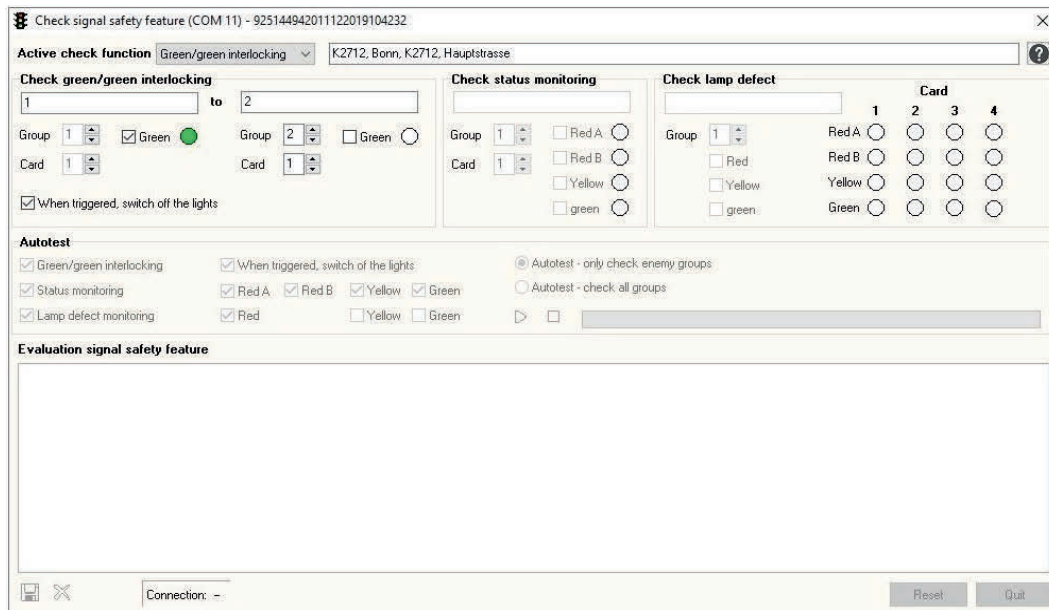

Signal safeguarding now checks whether the two signal groups that are switched on are hostile to each other and enters the result in the analysis window.

Depending on the setting **When triggered, switch off the lamps**, both green lamps that are on are switched off when triggered. After approx. 0.5 seconds, the green lamp is switched on again for the signal group from which the check is being made (adjusted on the left). The next test is then possible after this time.

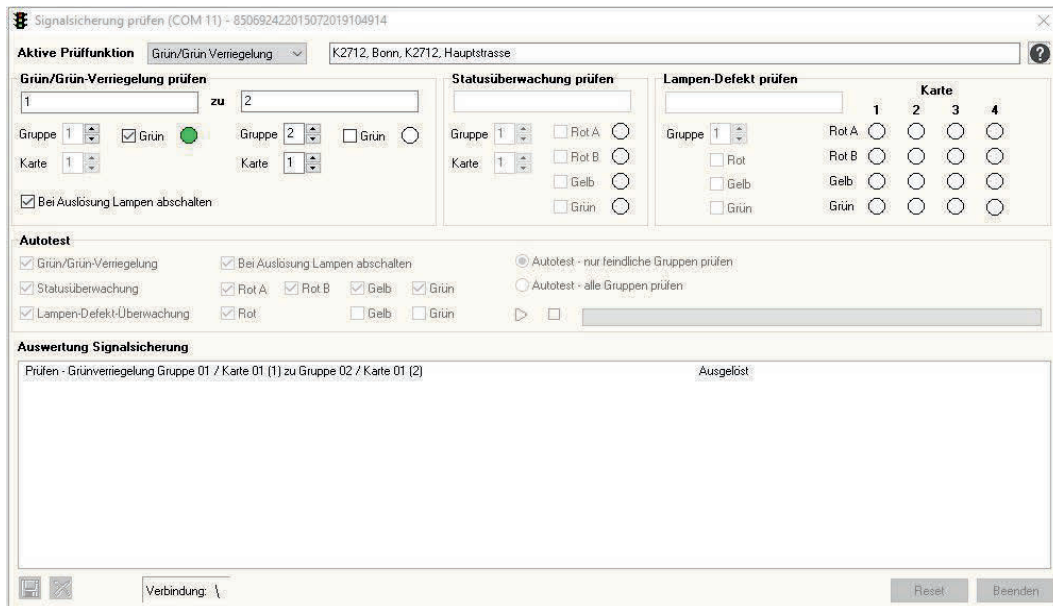

In the right boxes, select the next group to be checked against the signal group selected on the left and already switched on.

Repeat until all required signal groups have been checked against the signal group selected on the left and already switched on.

Once this is finished, select the next signal group at **Group / Card** for testing in the selection boxes on the left. Before this can be done, all green lamps that have been switched on must be switched off again.

Then repeat the procedures as described until all signal groups (possibly also several different power cards per group) have been checked against each other.

Notes:

- If **When triggered switch off the lamps** is active, both green lamps that are on are switched off when triggered. After about half a second, the green lamp adjusted on the left is switched on again and you can continue with the next test.
- If the green of the signal group selected on the right is switched on and you change the group or card there, the corresponding green is switched on immediately. If this is not wanted (e.g. to jump over a group), first you must switch off the green currently switched on at the right, and then adjust the required group and card.

9.1.3.1 External check of green/green interlocking

Alternatively, when checking green/green interlocking, it is also possible for the green of the signal group entered on the right to be switched on manually (e.g. by means of a wire jumper).

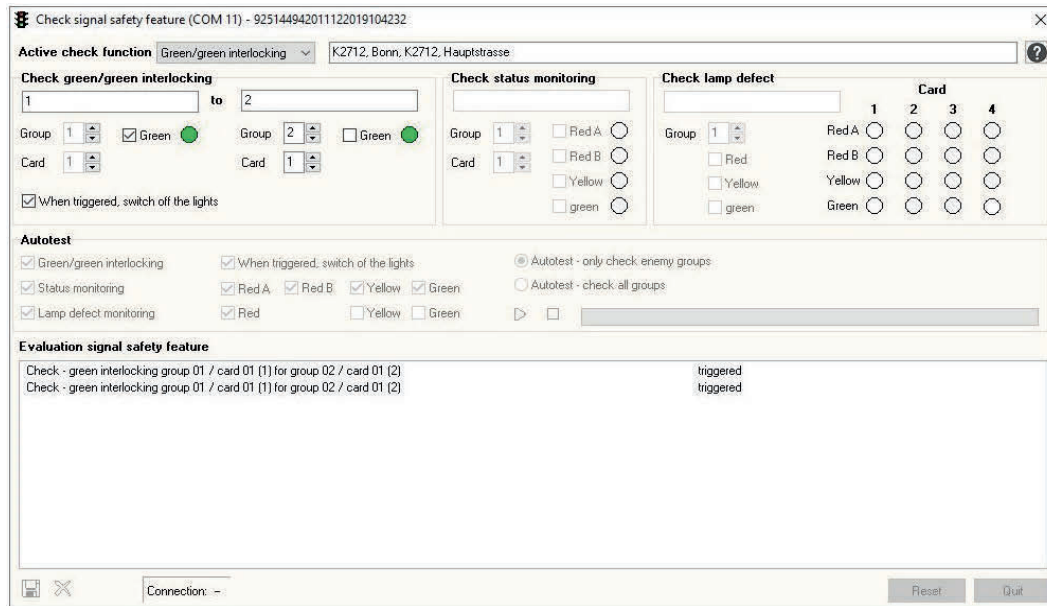

Note:

If a green lamp in a signal group is switched on externally, the selection box on the right is disabled when the green lamp is switched on.

9.1.3.2 Error OFF when checking green/green interlocking

If when green/green interlocking is being tested a triggering error occurs (card fault, 42V failure, measuring fault etc.), a corresponding message appears. The current test is cancelled and the **Check signal safeguarding** window is closed after confirming the error message.

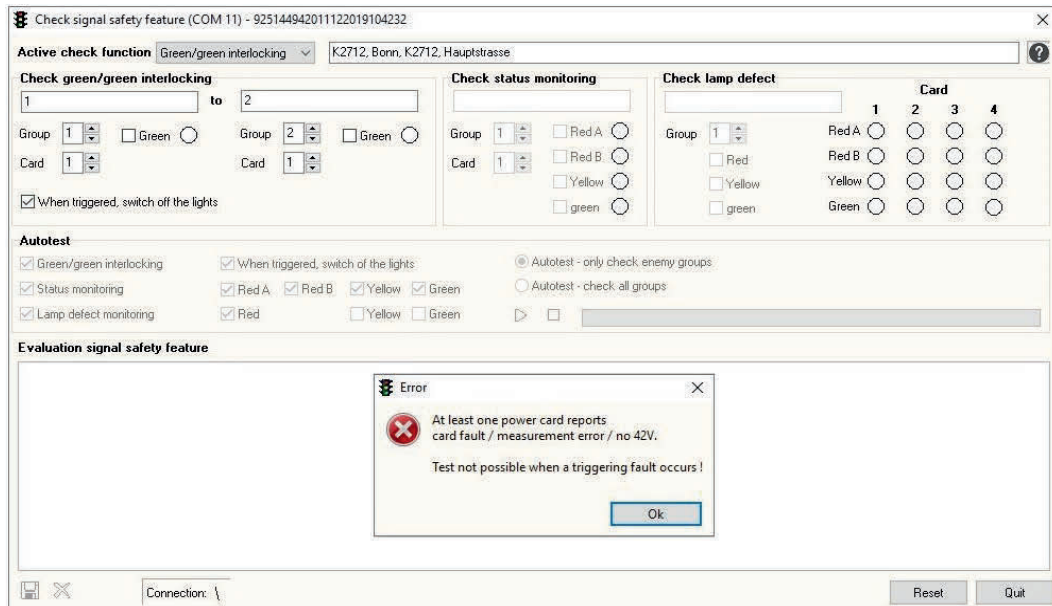

9.1.4 Check status monitoring

This function is used to check the individual status monitoring of the respective signal groups. This is done with **Check status monitoring**. To do so, select **Status monitoring** in the **Active check function**.

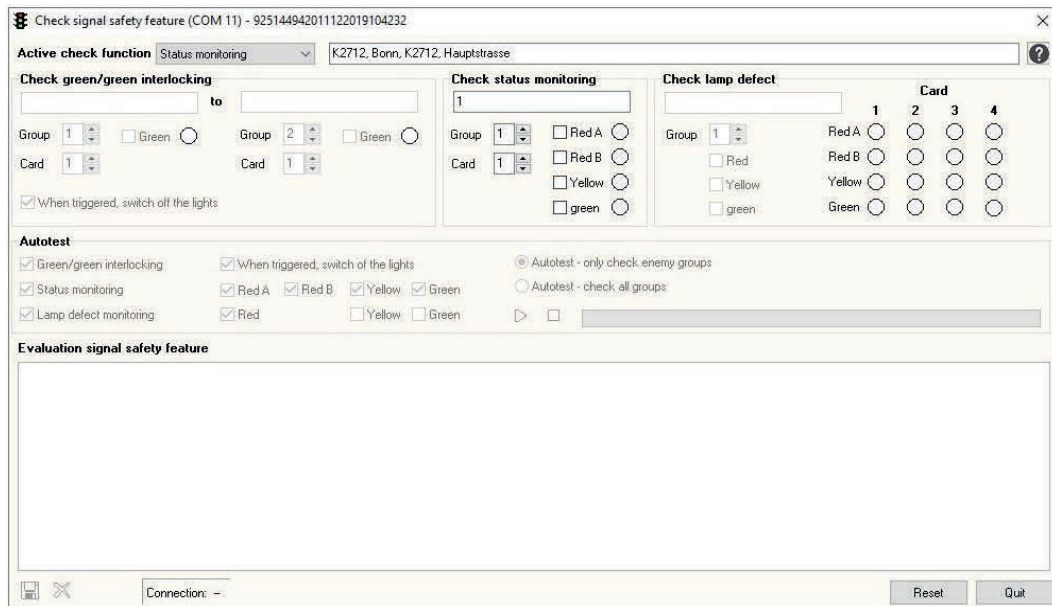

In the selection boxes, choose the required signal group in **Group / card** where you want to check status monitoring.

Generally, all feedback lamps are shown as a white circle (channel not switched on). If the feedback symbol appears square, status monitoring is deactivated for this channel.

If a tick is set for a channel (colour), the corresponding lamp output for this signal group is switched on and the colour of the feedback symbol changes accordingly.

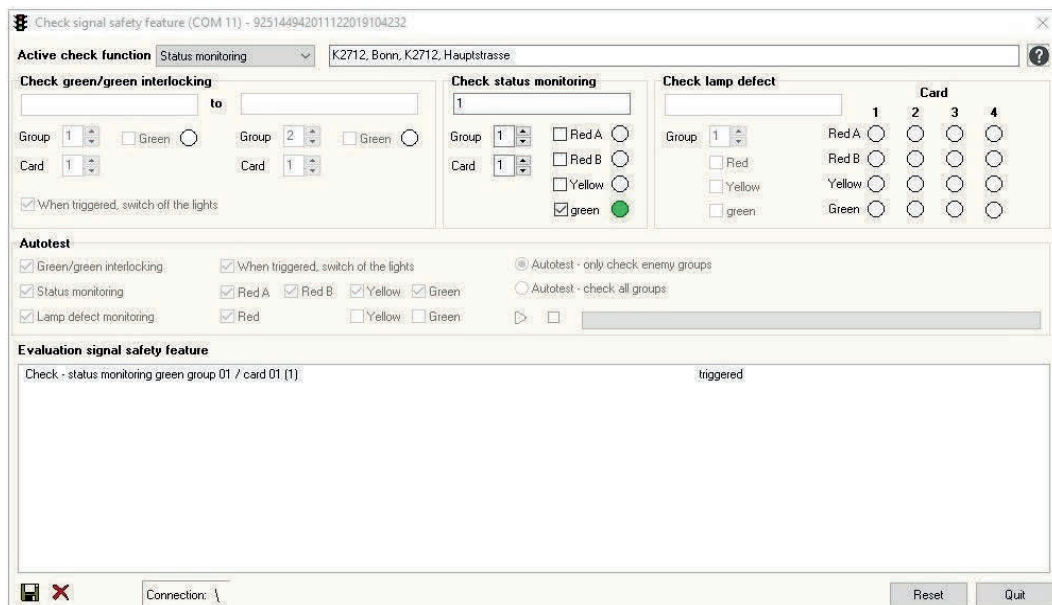

If status monitoring is activated for the colour switched on in this signal group, signal safeguarding is triggered and the switched on colour is switched off. If status monitoring is not activated for this colour, this channel (colour) lights up until it is switched off again. The respective test result is entered in the analysis window.

Note:

It is always only possible to switch one channel (colour) on for testing. Switching on the other channels (colour) is disabled for the time being.

9.1.4.1 External check of status monitoring

Alternatively, the channels (colour) can also be switched on manually for the check of status monitoring (e.g. by means of a wire jumper).

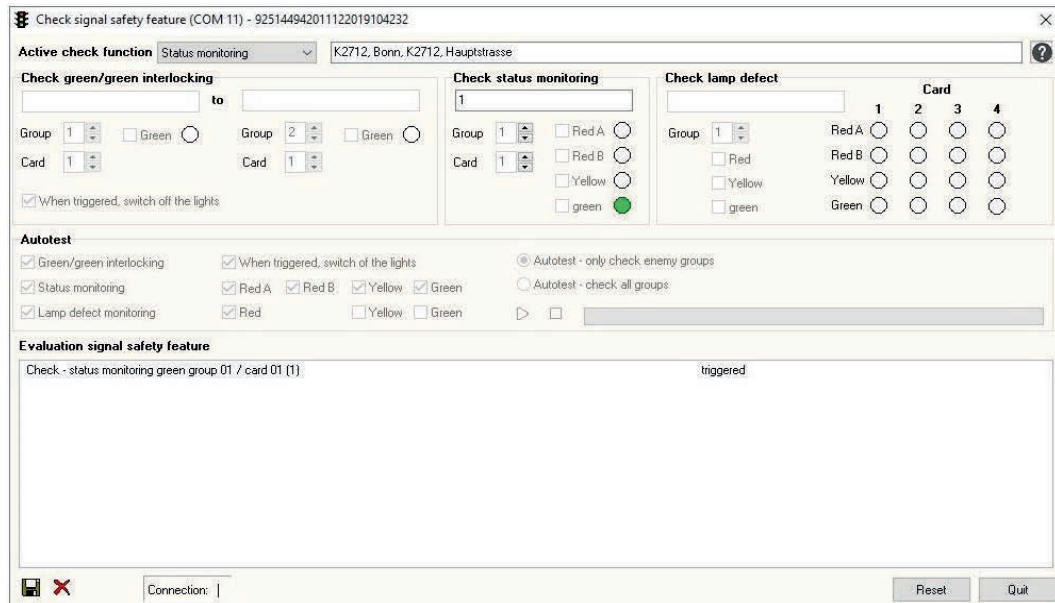

Note:

If a channel (colour) of a signal group is switched on externally, all selection possibilities for switching a channel (colour) on are disabled for the time being.

9.1.4.2 Error OFF when checking status monitoring

If a triggering error occurs (card fault, 42V failure, measuring fault etc.) when status monitoring is being checked, a corresponding message appears. The current test is cancelled and the **Check signal safeguarding** window is closed after confirming the error message.

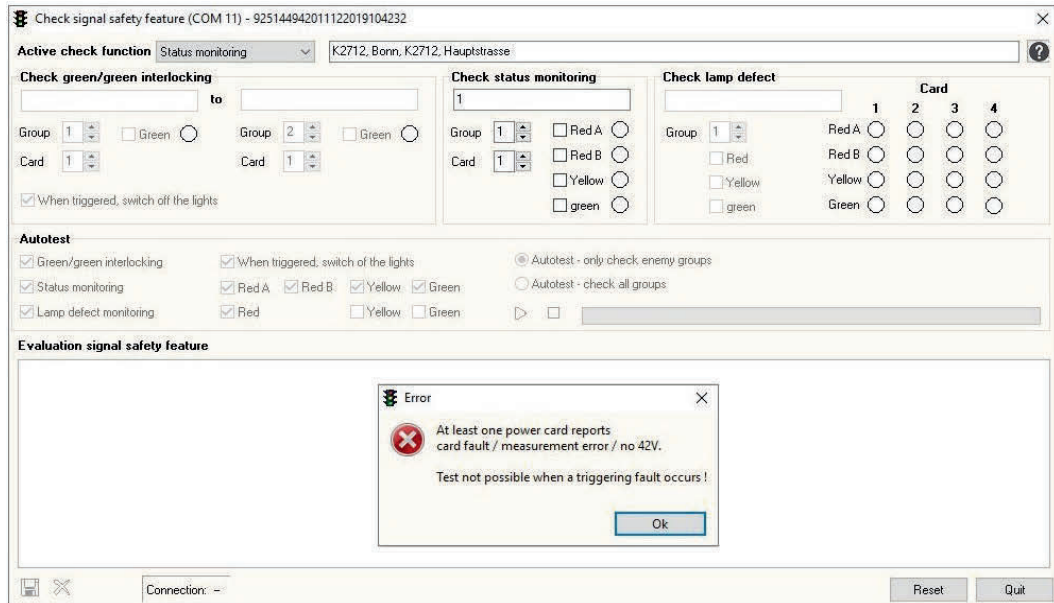

9.1.5 Check lamp defect

This function is used to check the individual lamp monitoring of the respective signal groups. This is done with **Check lamp defect**. To do so, select **Lamp monitoring** in the **Active check function**.

The screenshot shows the 'Check signal safety feature' software interface. The window title is 'Check signal safety feature (COM 11) - 925144942011122019104232'. The 'Active check function' is set to 'Lamp defect'. The location is 'K2712, Bonn, K2712, Hauptstrasse'. There are three main sections: 'Check green/green interlocking', 'Check status monitoring', and 'Check lamp defect'. The 'Check lamp defect' section shows a grid for Group 1 and Card 1, with columns for Red A, Red B, Yellow, and Green. Each cell contains a circle or square symbol, some of which are cross-hatched. Below these sections are 'Autotest' options and an 'Evaluation signal safety feature' area. The bottom of the window has a 'Connection:' field and 'Reset' and 'Quit' buttons.

In the selection boxes, choose the required signal group in **Group** where you want to check lamp monitoring.

If a tick is set for a channel (colour), the corresponding lamp outputs for all power cards present in this signal group are switched on.

On the right of this group box, feedback is shown for up to 4 power cards per signal group. Generally, all feedback lamps are shown as a white circle (channel not switched on). On selecting or activating a signal group, what you see here changes according to the number of existing power cards. If there are several power cards in a signal group (only EPB 24 / 48), a trigger logic (AND / OR) appears on the right.

The appearance of the various symbols shows which lamp channels are monitored and how the signal safeguarding trigger logic works.

Note:

If the cross-hatched round feedback lamps flash for the selected signal groups (monitored), this indicates that there are no lamps at this channel (colour). It is then not possible to test these channels (colours) and the corresponding checkboxes for switching this colour on are disabled. If the cross-hatched square feedback lamps flash (no lamp present, not monitored), the corresponding channel can be switched on.

9.1.5.1 Check lamp monitoring

Select the required signal group and switch the required channel on (colour). All existing feedback lamps light up accordingly. There can always only be one channel (colour) switched on: when you select red, all red A and red B channels are switched on.

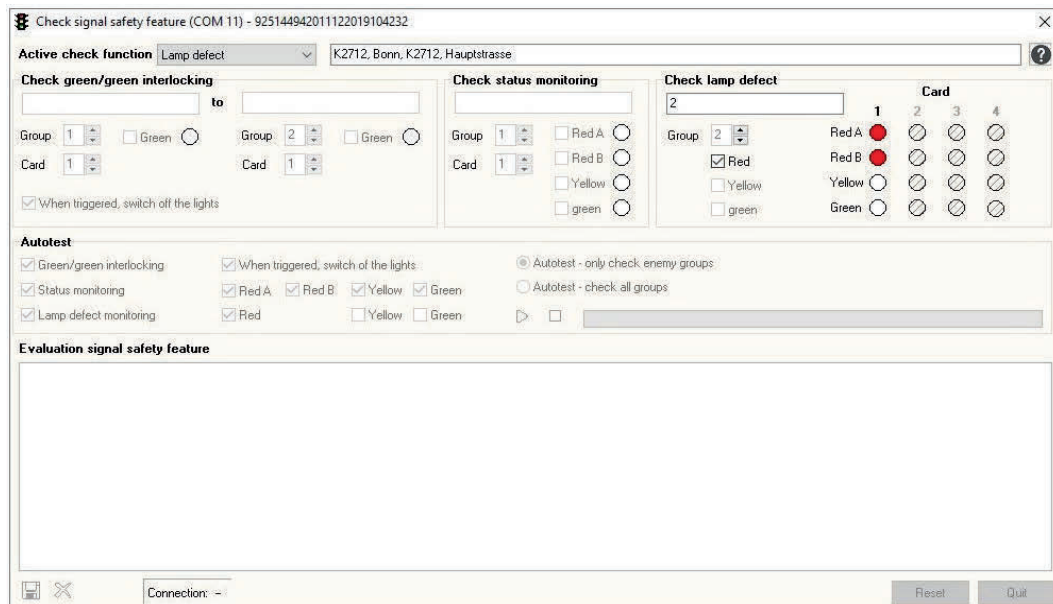

If you click the left mouse button on a feedback lamp that has been switched on, the corresponding lamp channel goes off and the feedback lamp appears cross-hatched. The signal safeguarding result is entered in the analysis window. If triggered, an **X** appears after the corresponding checkbox (depending on the logic). Alternatively, lamp monitoring can also be tested directly at the signal head / test panel. Remove the corresponding lamp. Here again, the signal safeguarding result is entered in the analysis window.

Notes:

- If signal safeguarding is triggered, all lamp outputs are switched off. No further test is possible. The causing fault must be remedied first.
- For red lamp monitoring, note the card logic (red A or red B / red A and red B).
- If there are several power cards in a signal group, the group logic must also be noted.
- Depending on the logic, it may be necessary to switch off/remove several lamps in the activated channel to trigger signal safeguarding accordingly.

9.1.5.2 Check red lamp monitoring logic OR

If the feedback lamps of a control card light up red, the trigger logic of red lamp monitoring is **ORed** (OR function) – i.e. signal safeguarding triggers as soon as one red lamp of this power card shows **Defect**. The signal safeguarding result is entered in the analysis window.

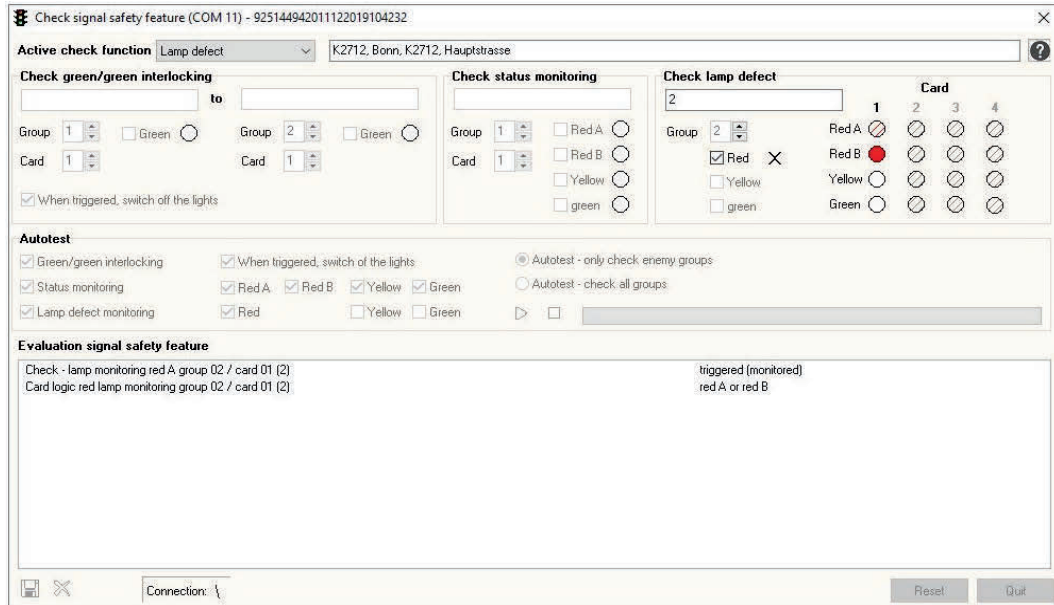

Note:

There is no trigger logic for yellow or green as these two colours only have one monitored output each.

9.1.5.3 Check red lamp monitoring AND

If the feedback lamps of a control card light up violet the trigger logic of red lamp monitoring is **ANDed (AND function)** – i.e. signal safeguarding triggers as soon as both red lamps of this power card show **Defect**.

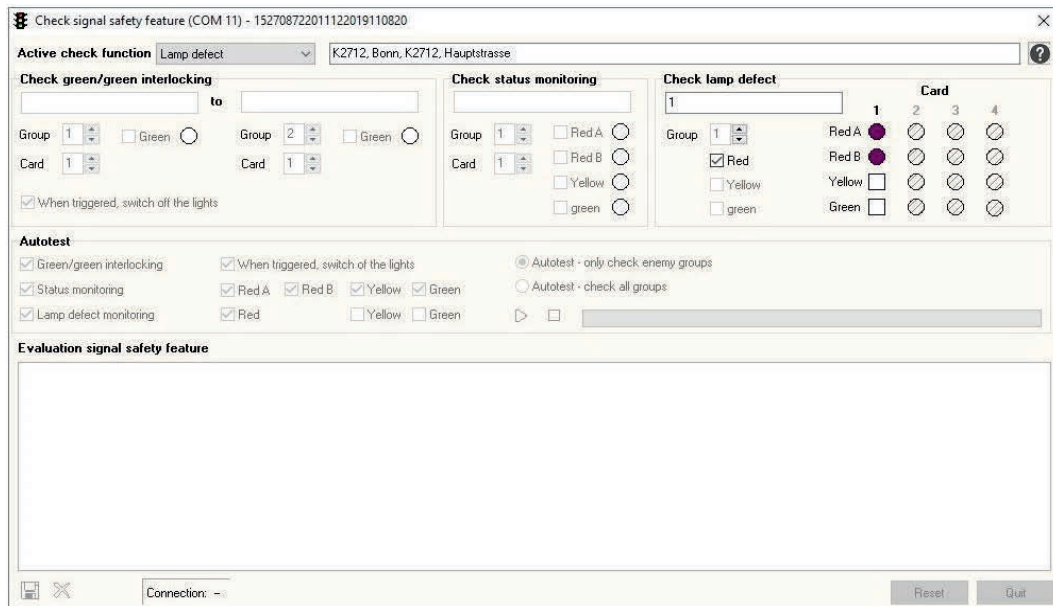

Signal safeguarding is not triggered if only one output is set to **Defect**. The signal safeguarding result is entered in the analysis window.

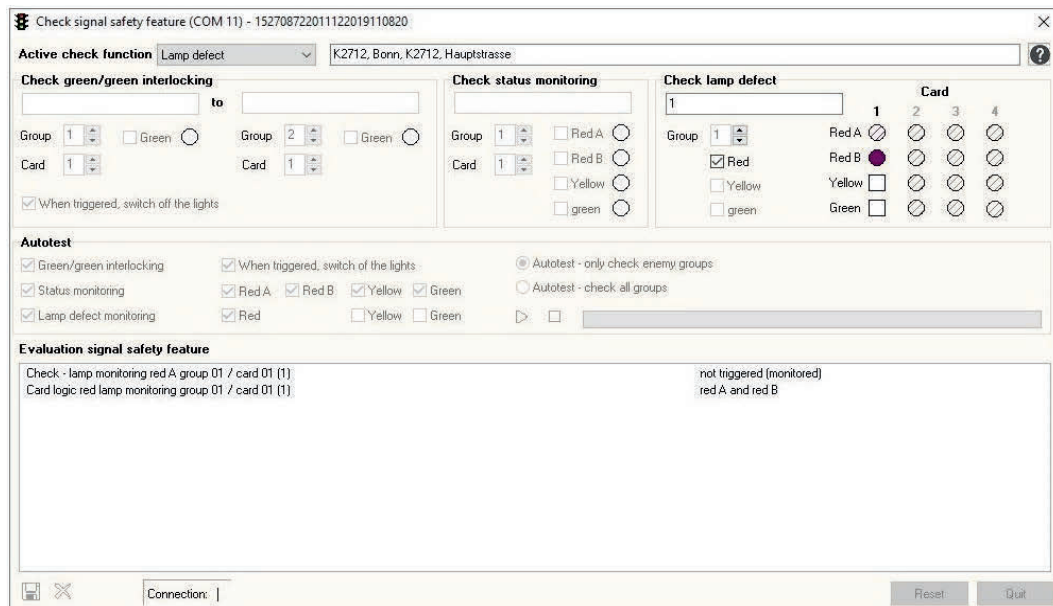

If the second output is also set to **Defect**, signal safeguarding is now triggered. The signal safeguarding result is entered in the analysis window.

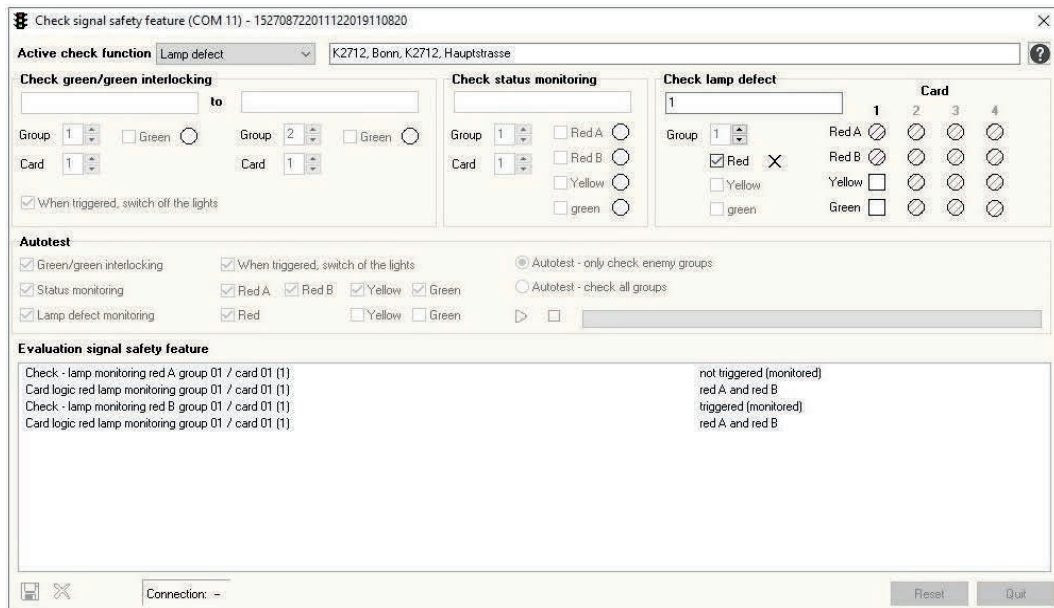

Note:

There is no trigger logic for yellow or green as these two colours only have one monitored output each.

9.1.5.4 Check lamp monitoring for several power cards

If several power cards are present, there are various logic combinations that trigger signal safeguarding for a defective lamp.

9.1.5.4.1 Card logic OR / group logic OR

In this example there are two power cards with card logic **OR** and group logic **OR**.

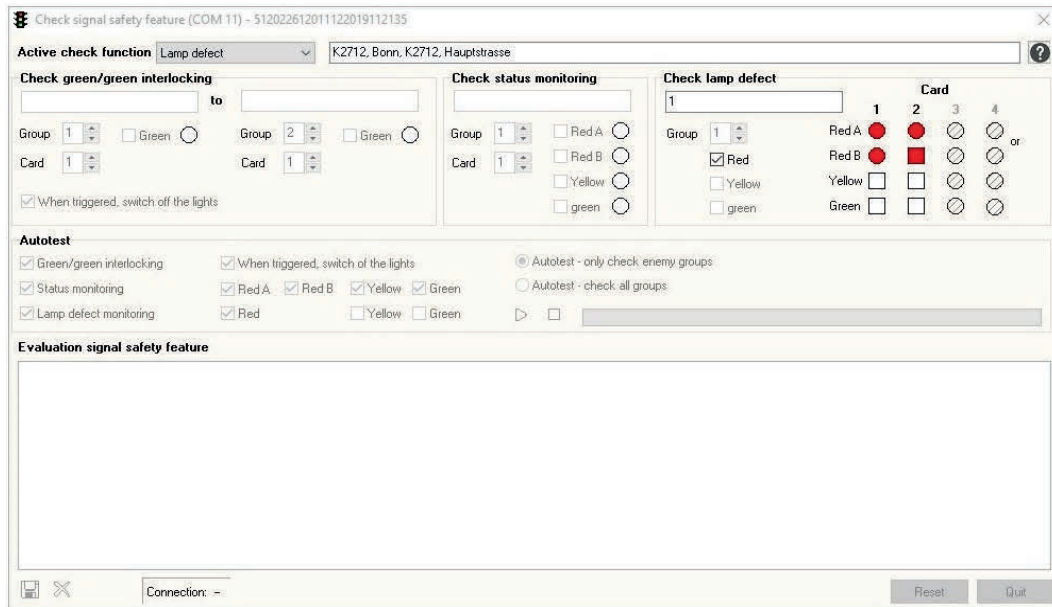

In this case, it is sufficient to set one of the existing red lamps to **Defect**. Signal safeguarding now triggers and the result is entered in the analysis window.

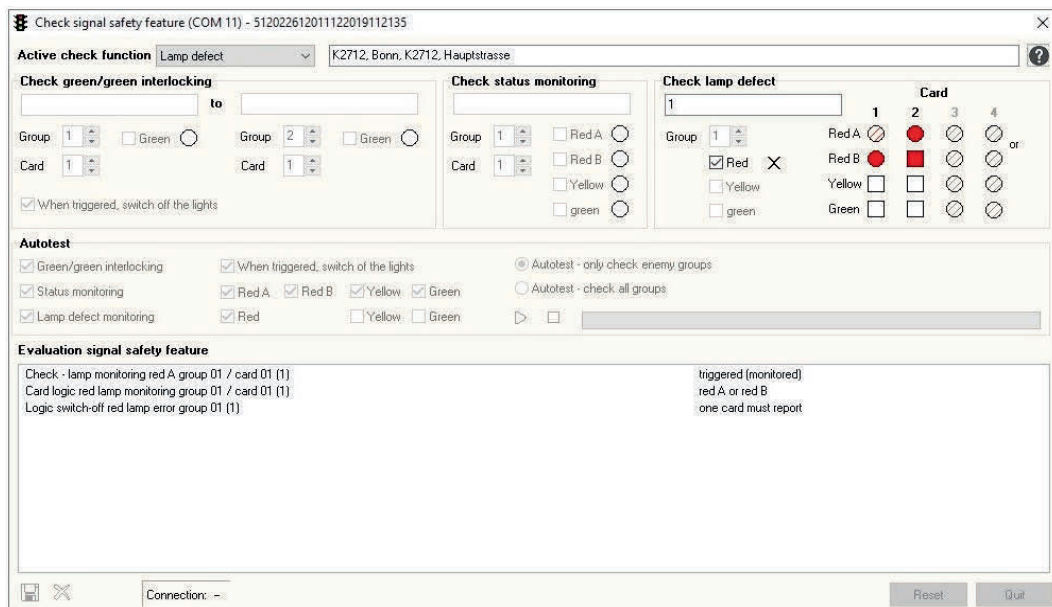

Note:

There is no card logic for yellow or green. If several power cards are present, signal safeguarding is triggered as soon as a lamp of the respective channel is set to **Defect**.

9.1.5.4.2 Card logic OR / group logic AND

In this example there are two power cards with card logic **OR** and group logic **AND**.

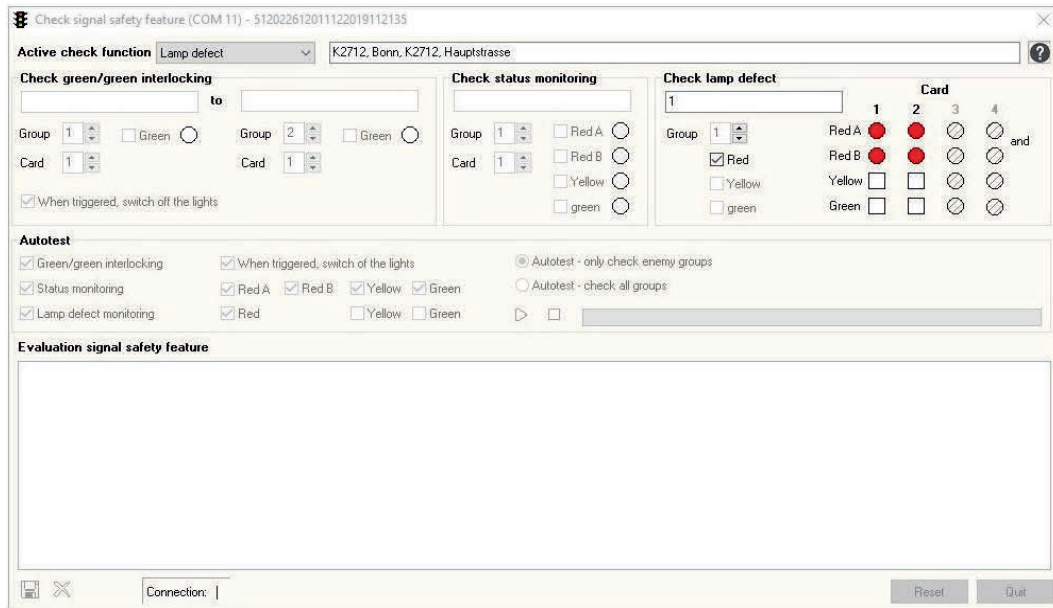

In this case, each power card must have a red lamp set to **Defect** to trigger signal safeguarding. The signal safeguarding result is entered in the analysis window.

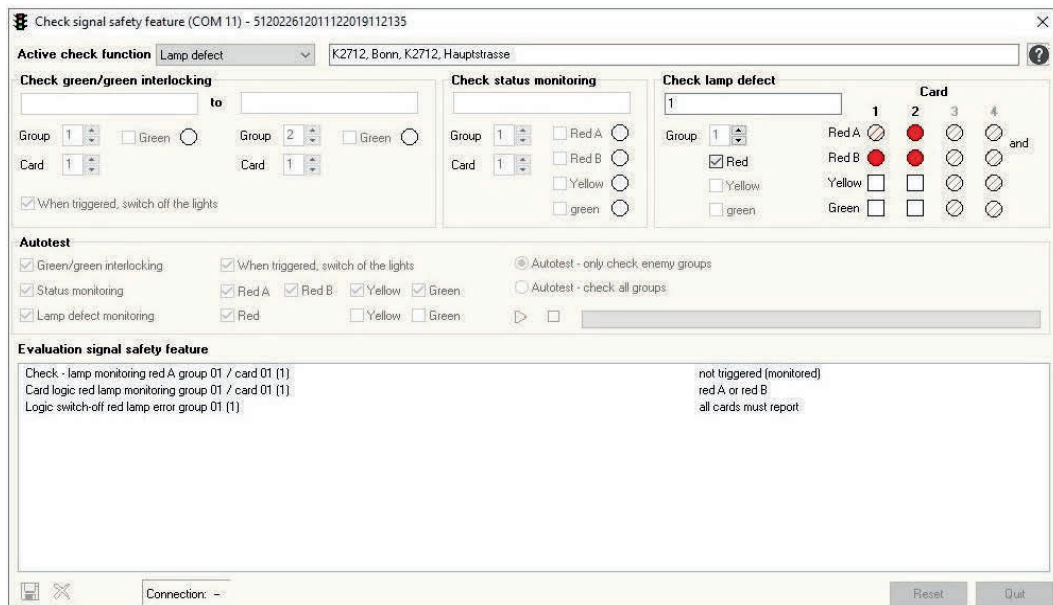

It is only when a red lamp is also set to **Defect** for the second power card that signal safeguarding is triggered. The signal safeguarding result is entered in the analysis window.

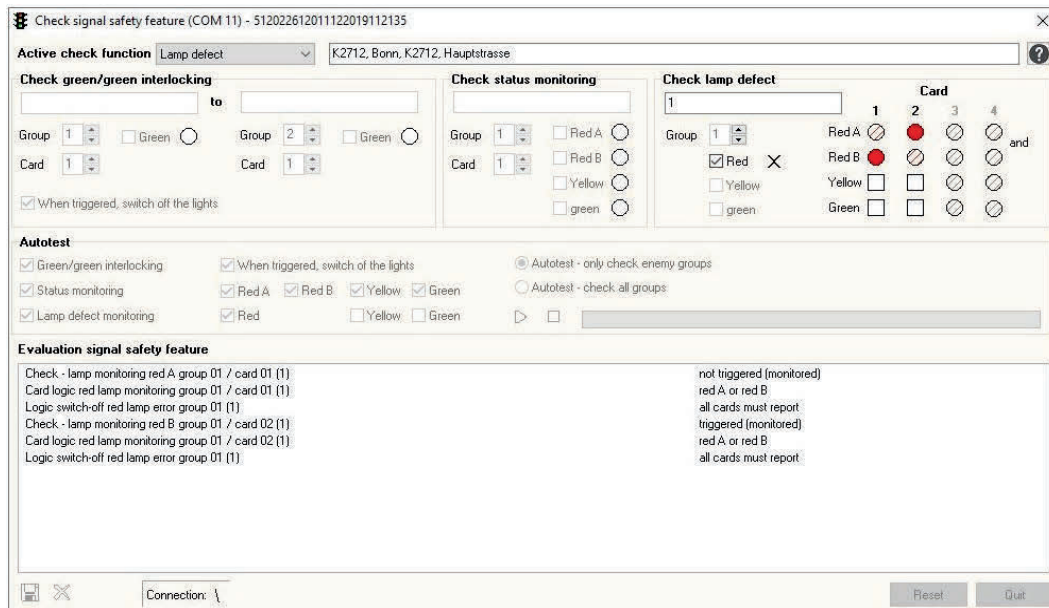

Note:

There is no card logic for yellow or green. If several power cards are present, signal safeguarding is triggered as soon as a lamp of the respective channel is set to **Defect** for each power card.

9.1.5.4.3 Card logic AND / group logic AND

In this example there are two power cards with card logic **AND** and group logic **AND**.

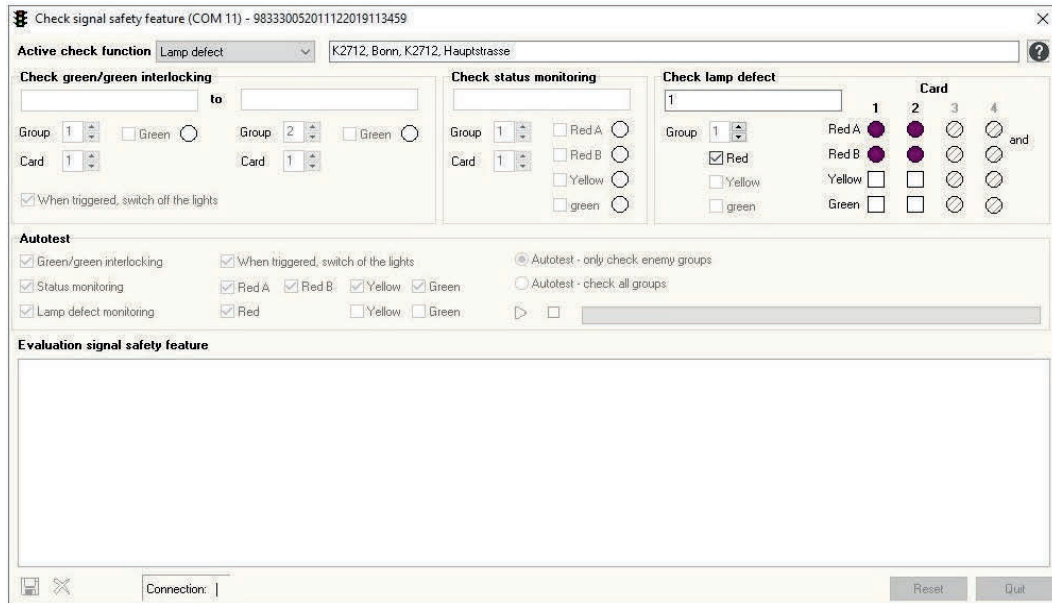

In this case, each power card must have both red lamps set to **Defect** to trigger signal safeguarding. The signal safeguarding result is entered in the analysis window.

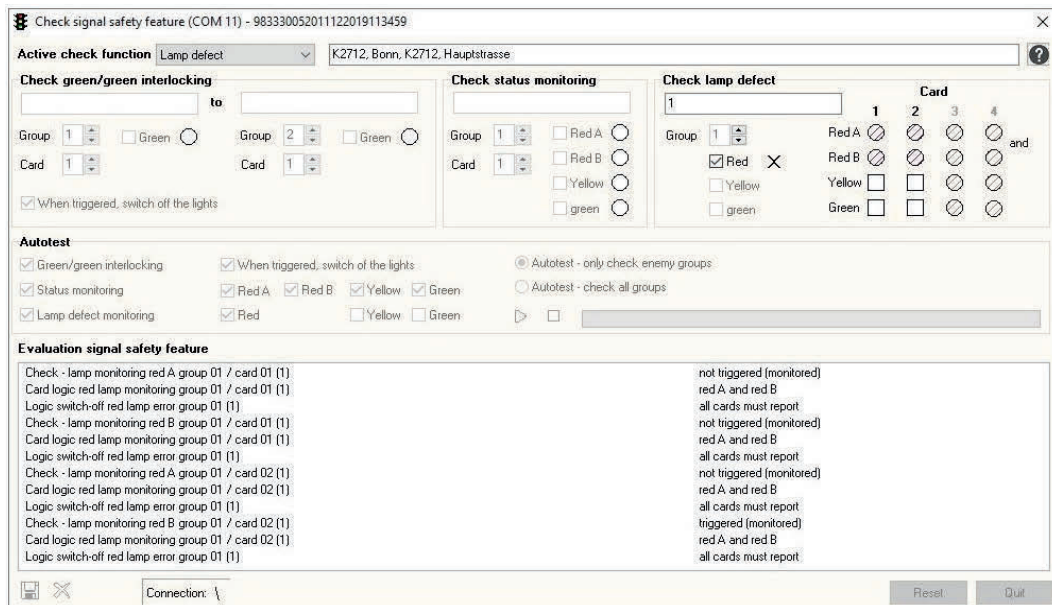

Note:

There is no card logic for yellow or green. If several power cards are present, signal safeguarding is triggered as soon as all lamps of the respective channel are set to **Defect** for each power card.

9.1.5.4.3 Card logic AND / group logic OR

In this example there are two power cards with card logic **AND** and group logic **OR**.

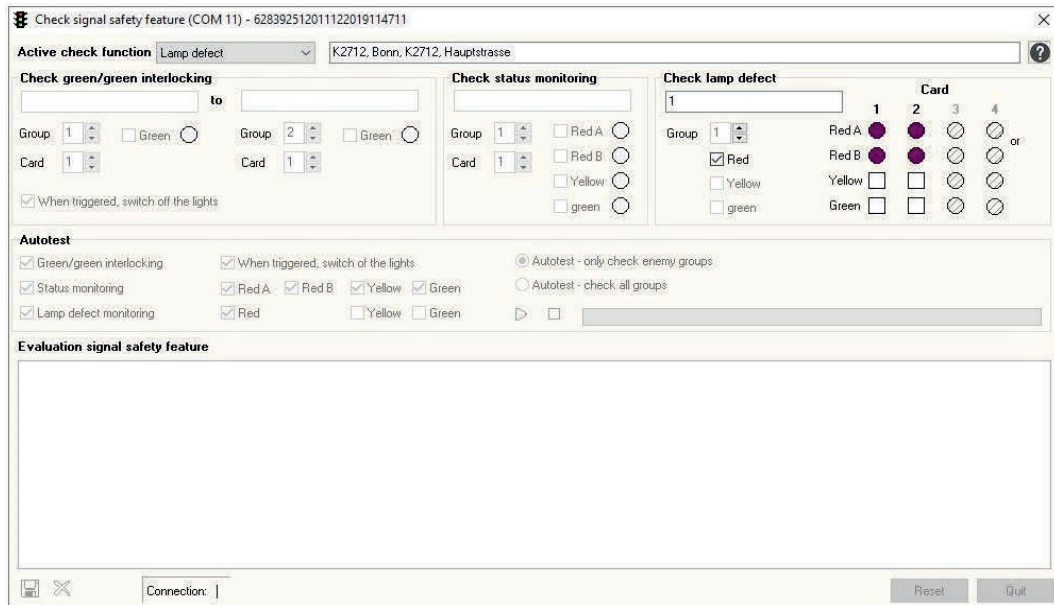

In this case, one power card must have both red lamps set to **Defect** to trigger signal safeguarding. However, signal safeguarding is not triggered if only one red lamp of a card is set to **Defect**.

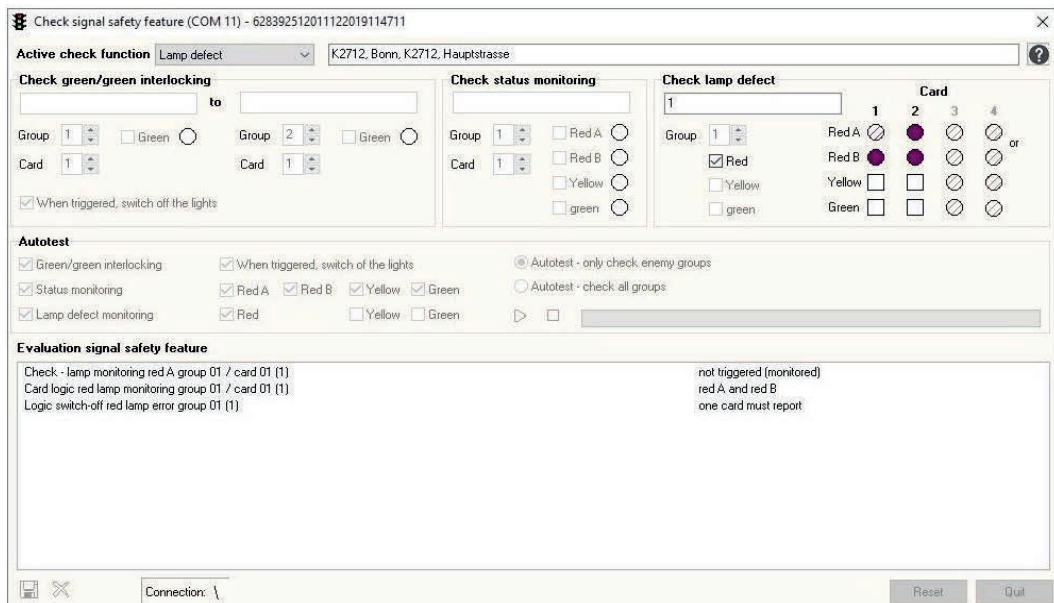

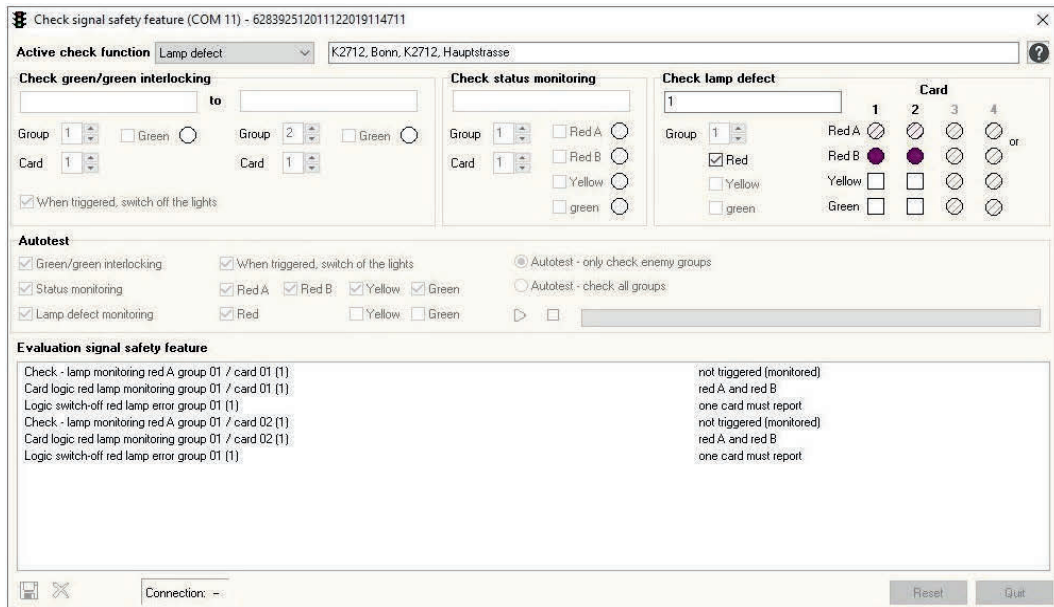

Signal safeguarding is only triggered when both red lamps of a card are set to **Defect**.

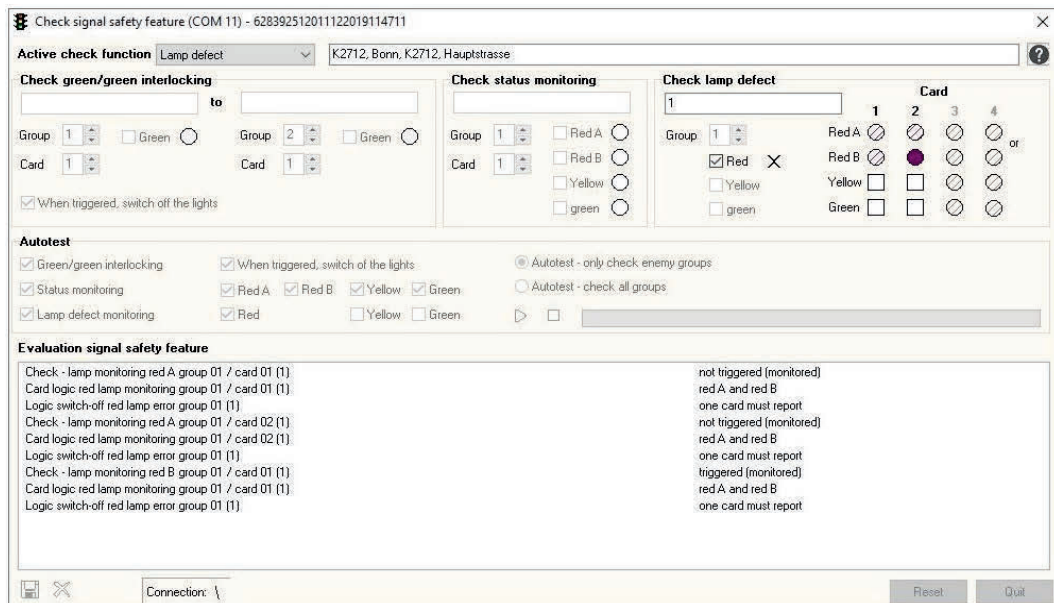

Note:

There is no card logic for yellow or green. If several power cards are present, signal safeguarding is triggered as soon as all lamps of the respective channel are set to **Defect** for one power card.

9.1.5.5 Error OFF when checking lamp defect

If when lamp defect monitoring is being tested a triggering error occurs (card fault, 42V failure, measuring fault etc.), a corresponding message appears. The current test is cancelled and the **Check signal safeguarding** window is closed after confirming the error message.

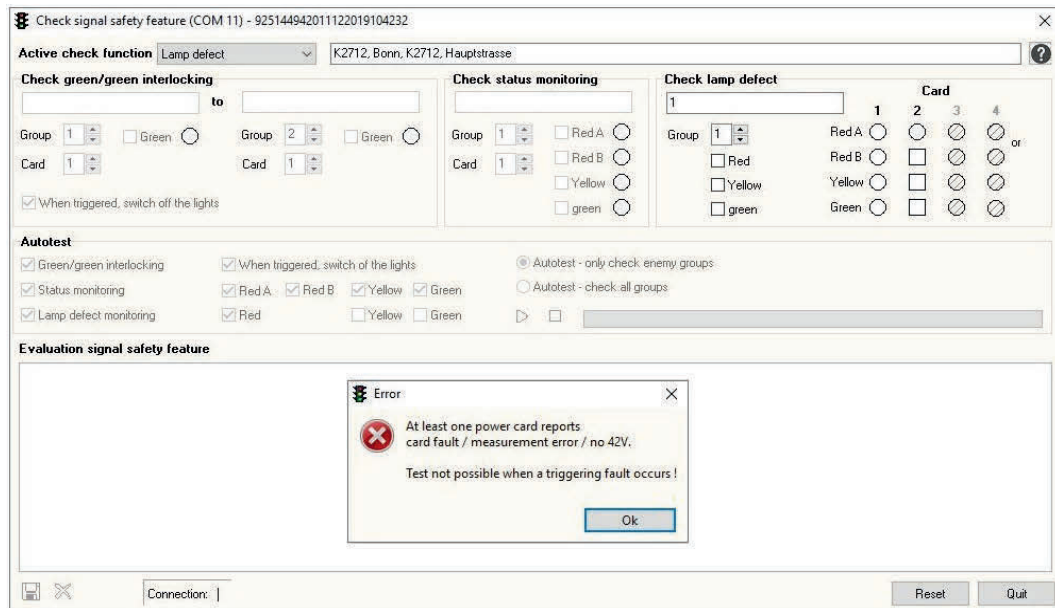

9.1.6 Auto test

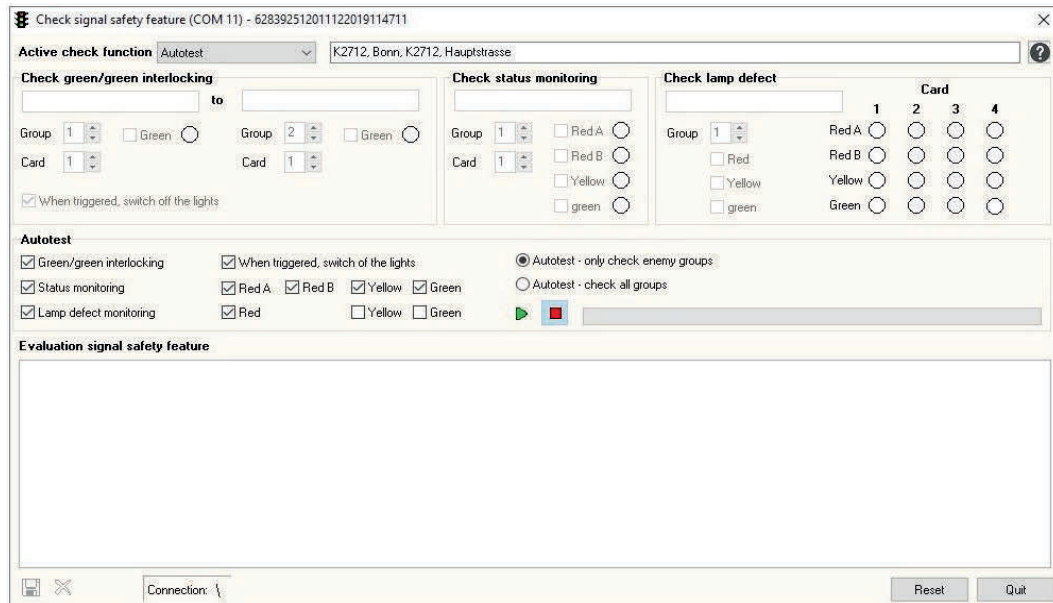

Auto test can be used for automatic testing of all monitoring functions. To do so, select **Auto test** in the **Active check function**.



The individual checkboxes let you select which monitoring functions are to be tested. The default settings and sequence are as follows:

- green/green interlocking (only hostile groups)
- status monitoring (all outputs)
- lamp monitoring (red A and red B)

As an option, use the checkboxes to deselect or additionally activate individual tests / outputs.

Press  to switch auto test on; press  to switch it off again. If auto test is on, all selection possibilities are disabled until auto test is completed.

The activated channels and feedback lamps show which test is currently in progress. A progress bar appears as a visual check and also tells you about the total number of tests to be carried out and how many have been completed.

The test is carried out at a fixed interval of one second.

If there are no hostile signal groups, the following message appears:

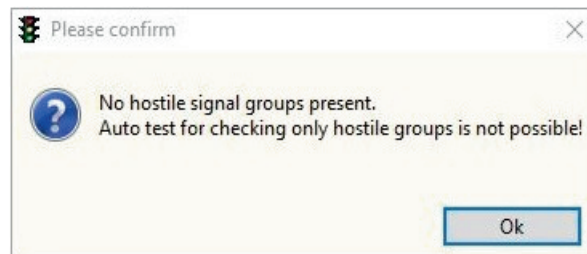

If this is confirmed, the auto test continues if other tests were selected (status, lamp monitoring). Auto test does not start if no other tests are selected.

A progress bar appears as a visual check and also tells you about the total number of tests to be carried out and how many have been completed.

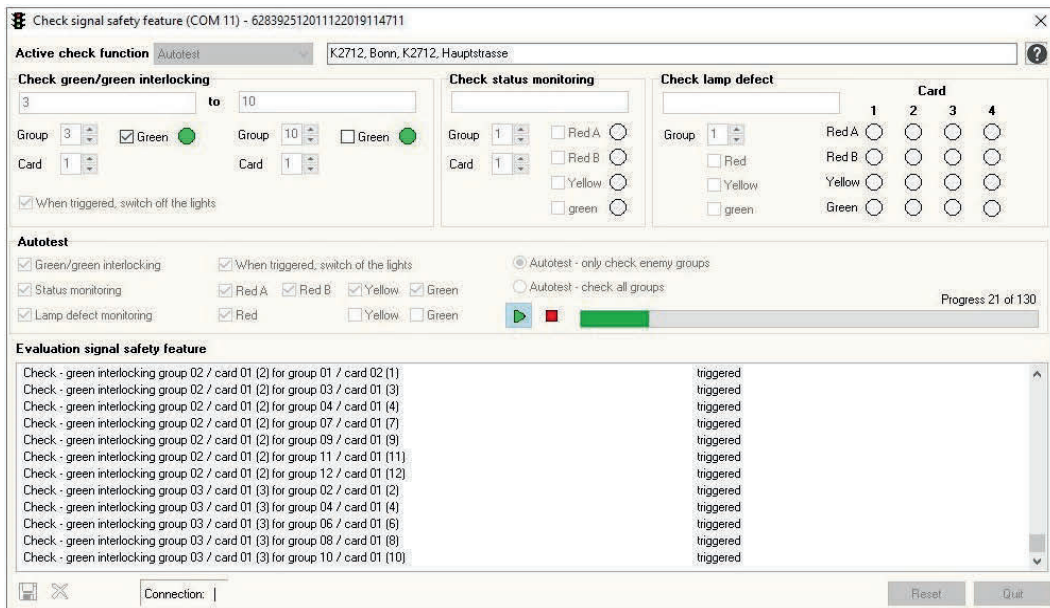

Once auto test has been completed, a corresponding message appears.

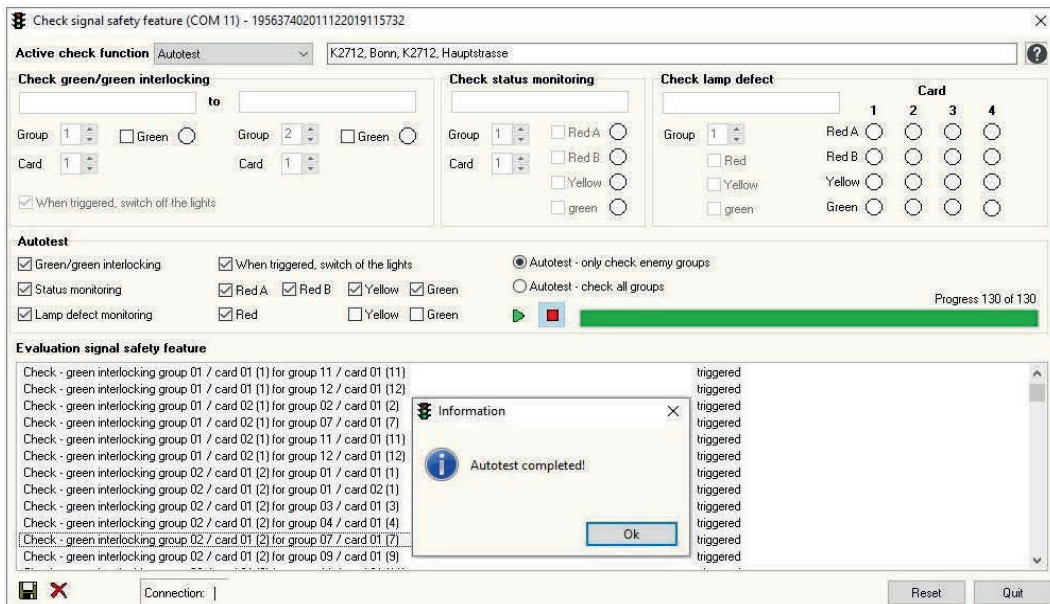

Note:

If auto test is active, already defective channels (colours) are jumped over when checking the lamp monitoring function (lamp defective). A corresponding entry is made in the analysis list. These entries appear red in the analysis list.

Check signal safety feature (COM 11) - 19563740201122019115732

Active check function: Autotest | K2712, Bonn, K2712, Hauptstrasse

Check green/green interlocking
Group 1 to Group 2
Card 1 to Card 1
 Green Green
 When triggered, switch off the lights

Check status monitoring
Group 12
Card 1
 Red A Red B Yellow green

Check lamp defect
Group 2
Card 1 2 3 4
Red A
Red B
Yellow
Green

Autotest
 Green/green interlocking When triggered, switch of the lights Autotest - only check enemy groups
 Status monitoring Red A Red B Yellow Green Autotest - check all groups
 Lamp defect monitoring Red Yellow Green
Progress 110 of 130

Evaluation signal safety feature

Logic switch-off red lamp error group 01 (1)	one card must report
Check - lamp monitoring red B group 01 / card 01 (3)	Test not possible, illuminant defective
Card logic red lamp monitoring group 01 / card 01 (1)	red A or red B
Logic switch-off red lamp error group 01 (1)	one card must report
Check - lamp monitoring red A group 01 / card 02 (1)	triggered (monitored)
Logic switch-off red lamp error group 01 (1)	one card must report
Check - lamp monitoring red B group 01 / card 02 (1)	not triggered (not monitored)
Logic switch-off red lamp error group 01 (1)	one card must report
Check - lamp monitoring red A group 02 / card 01 (2)	triggered (monitored)
Card logic red lamp monitoring group 02 / card 01 (2)	red A or red B
Check - lamp monitoring red B group 02 / card 01 (2)	triggered (monitored)
Card logic red lamp monitoring group 02 / card 01 (2)	red A or red B

Connection: | Reset Quit

9.1.6.1 Auto test option

This setting defines which signal groups are checked in auto test of green/green interlocking. In the default setting **only check hostile groups**, the check is only carried out for signal groups that are hostile to each other.

When set to **check all groups**, every signal group is checked against all signal groups, The test then takes longer. Not all test results of the non-hostile signal groups are entered in the analysis list.

Depending on the setting **when triggered, switch off the lamps**, both switched on green lamps are switched off when triggered. After approx. 0.5 seconds, the green lamp is switched on again for the signal group from which the check is being made (adjusted on the left). At the end of this time, auto test continues with the next check.

Note:

If there are several power cards per group (only EPB 24 / 48/), auto test goes through them one after the other.

9.1.6.2 Error OFF during active auto test

If a triggering error occurs (card fault, 42V failure, measuring fault etc.) during auto test, a corresponding message appears. The current test is cancelled and the **Check signal safeguarding** window is closed after confirming the error message.

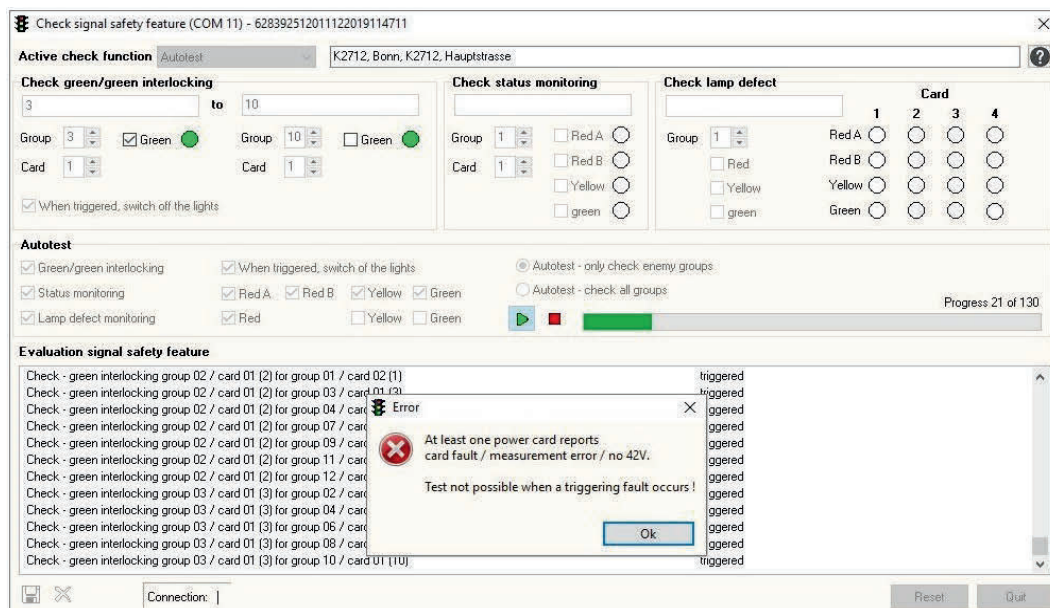

9.1.7 Protocolling test results for checking signal safeguarding

The **Evaluation signal safeguarding** shows all signal safeguarding feedback messages for all tests.

Each entry always consists of the following:

Check – which monitoring, which channel (lamp), group/card, group name(s) – signal safeguarding feedback.

Evaluation signal safety feature	
Check - green interlocking group 02 / card 01 (2) for group 01 / card 02 (1)	triggered
Check - green interlocking group 02 / card 01 (2) for group 03 / card 01 (3)	triggered
Check - green interlocking group 02 / card 01 (2) for group 04 / card 01 (4)	triggered
Check - green interlocking group 02 / card 01 (2) for group 07 / card 01 (7)	triggered
Check - green interlocking group 02 / card 01 (2) for group 09 / card 01 (9)	triggered
Check - green interlocking group 02 / card 01 (2) for group 11 / card 01 (11)	triggered
Check - green interlocking group 02 / card 01 (2) for group 12 / card 01 (12)	triggered
Check - green interlocking group 03 / card 01 (3) for group 02 / card 01 (2)	triggered
Check - green interlocking group 03 / card 01 (3) for group 04 / card 01 (4)	triggered
Check - green interlocking group 03 / card 01 (3) for group 06 / card 01 (6)	triggered
Check - green interlocking group 03 / card 01 (3) for group 08 / card 01 (8)	triggered
Check - green interlocking group 03 / card 01 (3) for group 10 / card 01 (10)	triggered

9.1.7.1 Save signal safeguarding protocol

Press  **Save protocol** to write the contents of the analysis window in a file that can be viewed/printed later on.

The file is stored in the following directory: \\User\Documents\Ampeltools\Data Remote Monitoring

Note:

This button is disabled when a test function is active

9.1.7.2 Miscellaneous

Press **Reset** to reset all selection possibilities to the basic setting.

Note:

This button is disabled when a test function is active

9.1.8 Analyse signal safeguarding check

Click here to open the following window.

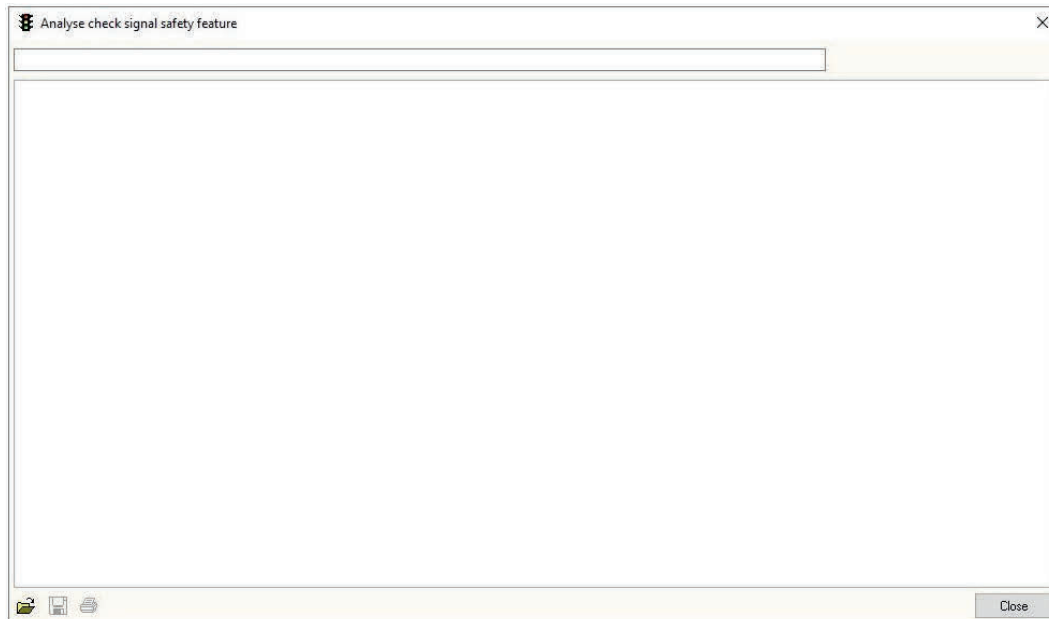

9.1.8.1 Load protocol file

Press  **Load protocol** to load an existing protocol file. It appears in the analysis window.

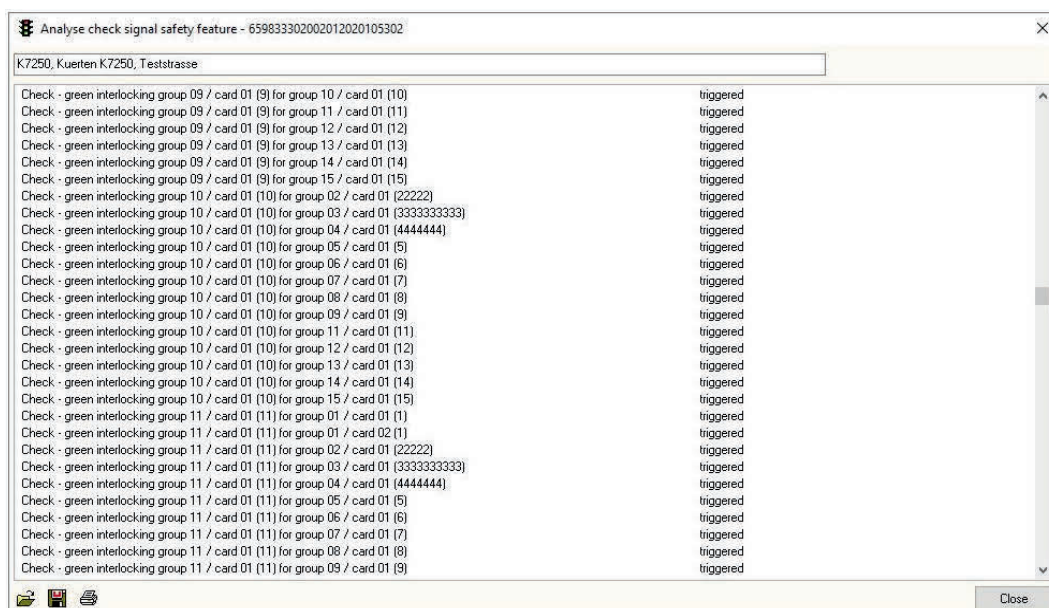

9.1.8.2 Save protocol file as

Press  **Save protocol file as** to save the currently loaded protocol file under another file name. The file is stored in the following directory: \\User\Documents\Ampeltools\Data Remote Monitoring

9.1.8.3 Print protocol file

Press  **Print protocol** to print the contents of the analysis window on the adjusted standard printer.

9.1.8.4 Print marked area

Click the right mouse button in the analysis list to open a popup menu. Select **Print marked area** to print the marked area.

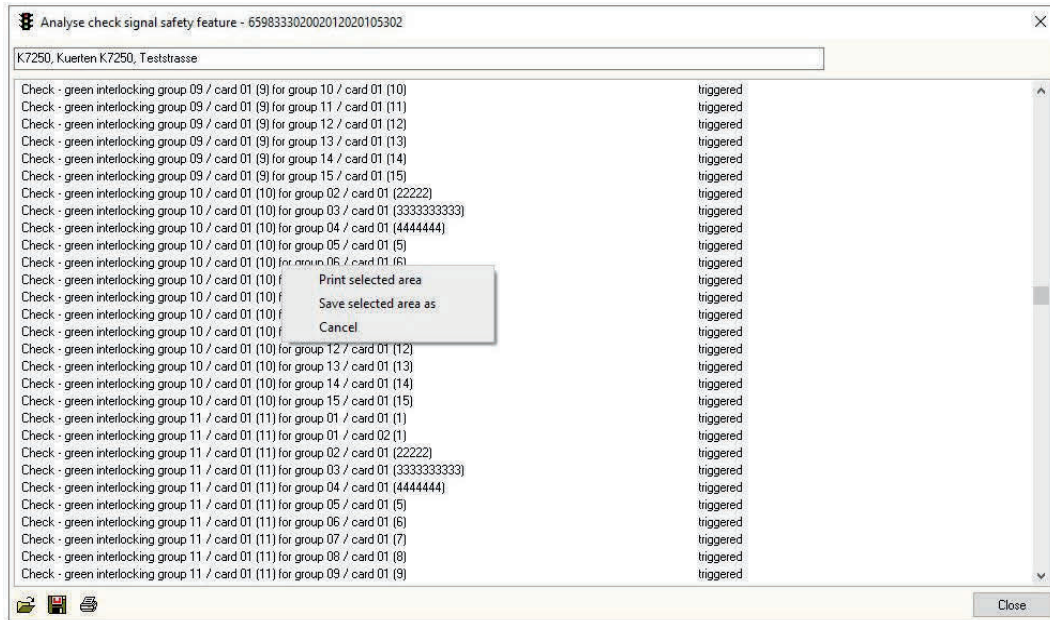

9.1.8.5 Save marked area

Click the right mouse button in the analysis list to open a popup menu. Select **Save marked area** to save the marked area under another file name. A corresponding dialogue appears.

10. Configuration local public transport module

This mask can be used to configure the local public transport module instead of a terminal program when operating the local public transport module at traffic light systems in the MPB series or using the relay function of bus 0.

For system types EPB 12 / 24 / 48, use the control computer for configuration (from version 6.9x).

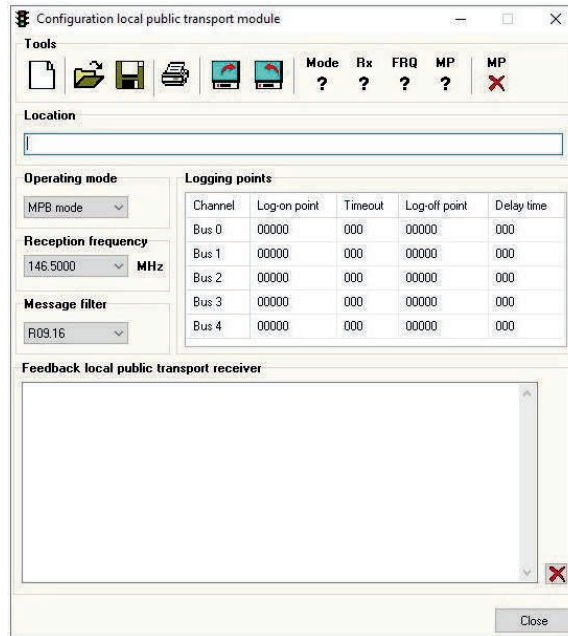

Note:

Generally, all functions working on the basis of a connection with the local public transport receiver need to have the programming mode activated in the receiver. To do so, set dip switch No. 10 to **ON**. If it is switched off, it is not possible to set up a connection to the local public transport receiver and a corresponding error message appears.

Once programming is completed, dip switch no. 10 has to be switched **OFF** again. The feedback window shows whether the programming mode is activated or deactivated.

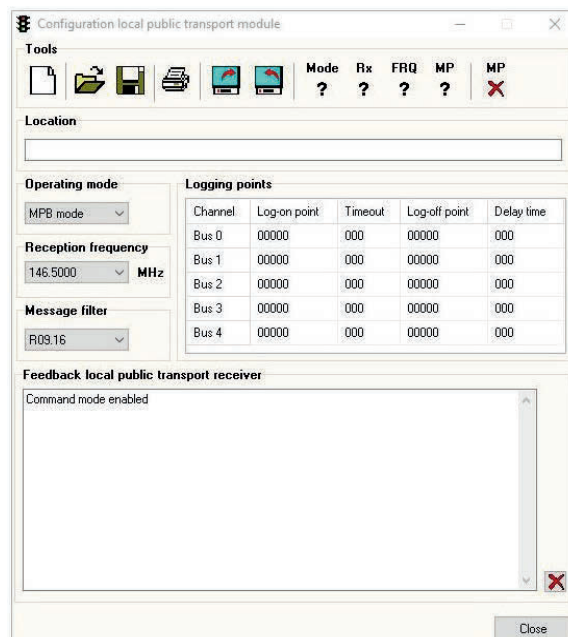

10.1 Tools

Here you find the most frequently used functions, e.g. data management, printing, data exchange with the local public transport module and other query functions for current programming.

10.1.1 New configuration

Press  to reset all data to the basic setting. If any data have been changed, a query appears whether the existing data should be saved.

10.1.2 Load data

Select  to open a selection dialogue for loading saved data of a configuration.

10.1.3 Save data

Select  to open a selection dialogue for saving the existing data.

10.1.4 Print data

Select  to open a dialogue for printing the existing data.

10.1.5 Send data to the local public transport receiver

Select  to send the current data to the local public transport receiver. The feedback window shows the respective send and receive commands; a progress bar runs while transmission is in progress.

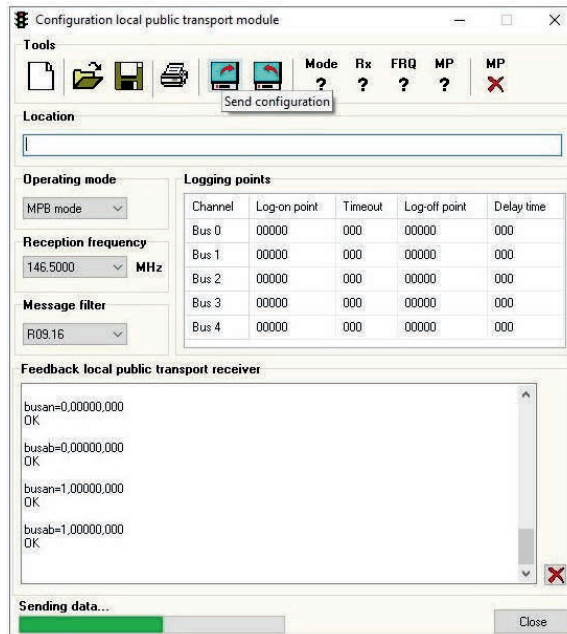

Note:

A corresponding error message appears if there is no connection to the local public transport receiver.

In this case, please check the connection or whether the local public transport receiver is in programming mode.

10.1.6 Read data from the local public transport receiver

Select  to read the current data from the local public transport receiver. The data are then entered in the corresponding boxes.

As with **Send data**, here again the feedback window shows the respective send and receive commands; a progress bar runs while transmission is in progress.

Note:

A corresponding error message appears if there is no connection to the local public transport receiver.

In this case, please check the connection or whether the local public transport receiver is in programming mode.

10.1.7 Query operating mode

Select  to query the current mode of the local public transport receiver. This then appears in the corresponding selection box.

Note:

A corresponding error message appears if there is no connection to the local public transport receiver.

In this case, please check the connection or whether the local public transport receiver is in programming mode.

10.1.8 Query message filter

Select  to query the current message filter of the local public transport receiver. This then appears in the corresponding selection box.

Note:

A corresponding error message appears if there is no connection to the local public transport receiver.

In this case, please check the connection or whether the local public transport receiver is in programming mode.

10.1.9 Query frequency

Select  to query the current frequency of the local public transport receiver. This then appears in the corresponding selection box.

Note:

A corresponding error message appears if there is no connection to the local public transport receiver.

In this case, please check the connection or whether the local public transport receiver is in programming mode.

10.1.10 Query logging points

Select  to query the current logging points of the local public transport receiver. This then appears in the corresponding selection boxes.

Note:

A corresponding error message appears if there is no connection to the local public transport receiver.

In this case, please check the connection or whether the local public transport receiver is in programming mode.

10.1.11 Delete all logging points

Select  for all existing logging points of the local public transport receiver to be deleted with a confirmation query.

Note:

A corresponding error message appears if there is no connection to the local public transport receiver.

In this case, please check the connection or whether the local public transport receiver is in programming mode.

10.2 Location

Here it is possible to enter a text (max. 50 characters) to help allocate the data in a printout.

10.3 Operating mode

The required operating mode is entered here. There is a choice between MPB mode and EPB mode.

10.3.1 Send operating mode

Click the right mouse button on the operating mode selection box to open a selection menu. Select **Send operating mode** to send the adjusted operating mode to the local public transport receiver.

Note:

A corresponding error message appears if there is no connection to the local public transport receiver.

In this case, please check the connection or whether the local public transport receiver is in programming mode.

10.4 Reception frequency

The required reception frequency is adjusted in this selection box. There is a choice from all frequencies in the installed frequency list.

Note:

If no frequency list can be found, the selection box is disabled.

10.4.1 Send reception frequency

Click the right mouse button on the reception frequency mode selection box to open a selection menu. Select **Send reception frequency** to send the adjusted reception frequency to the local public transport receiver.

Note:

A corresponding error message appears if there is no connection to the local public transport receiver.

In this case, please check the connection or whether the local public transport receiver is in programming mode.

10.4.2 Add reception frequency

If the required frequency is not present, manual additions can be made to the frequency list. To do so, click the right mouse button in the reception frequency selection box and select **Add reception frequency**.

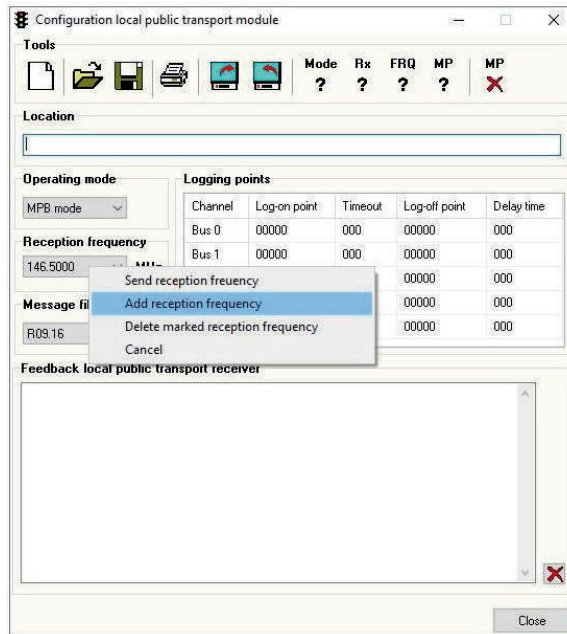

The corresponding input mask opens.

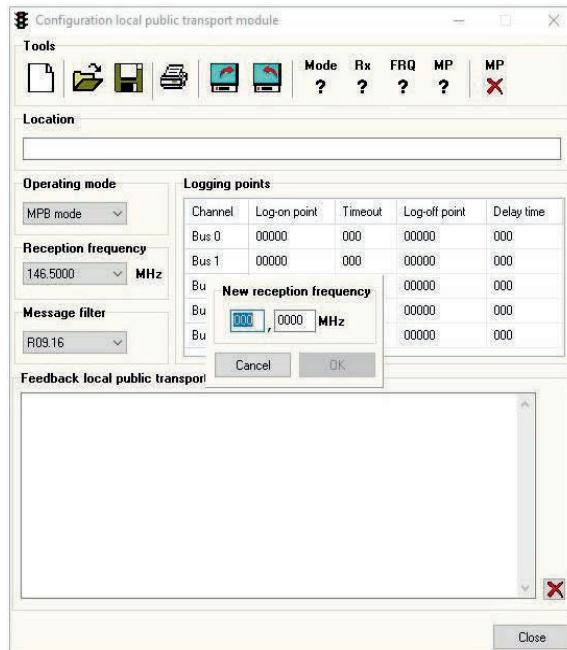

Here you can enter the required frequency. Click on **OK** to save it in the frequency list.

Note:

Depending on the technical specification of the receiver, it is possible to enter frequencies of 140-174 MHz (VHF range) or 410-470 MHz (UHF range). The frequency must be divisible by 5 or 6.25. If an invalid frequency is entered, an error message appears and the entries are deleted.

10.4.3 Delete reception frequency

To delete a frequency from the frequency list, click the right mouse button in the frequency selection box. In the selection menu, select **Delete marked reception frequency**. This entry is then deleted with a confirmation query.

Note:

Deleting all frequencies from the frequency list disables the frequency selection box. It is not enabled again until there are frequencies in the frequency list.

10.5 Message filter

This selection box is used to select the required telegram filter. Types R09.12 to R09.18 are available, or all messages.

Note:

If the telegram filter is set to **all messages**, the local public transport receiver evaluates all received message types (also not R09.xx).

10.5.1 Send message filter

Click the right mouse button on the message filter selection box to open a selection menu. Select **Send message filter** to send the adjusted message filter the local public transport receiver.

Note:

A corresponding error message appears if there is no connection to the local public transport receiver.

In this case, please check the connection or whether the local public transport receiver is in programming mode.

10.6 Logging points

Logging points can be entered in the table for up to 5 channels (bus 0 to bus 4). The following can be entered for each channel:

- Log-on point (0 - 65536)
- Timeout (0, or 6 - 999 seconds)
- Log-off point (0 - 65536)
- Delay time (0 - 999 seconds)

Please refer to the "Local Public Transport Receiver Manual" for details about using the individual channels.

Note:

If an entry in an input box is incorrect, a corresponding message appears and the value is set to the default.

10.6.1 Delete logging points

To delete a logging point (channel), click the right mouse button in any input box of a channel. Select **Delete logging point** in the corresponding selection menu. All values for this channel (log-on point, timeout, log-off point and delay time) are set to the default without a confirmation query.

10.6.2 Send logging point

Click the right mouse button in any input box of a channel to open a selection menu. Select **Send logging point** sends the values for this channel (log-on point, timeout, log-off point and delay time) to the local public transport receiver.

Note:

A corresponding error message appears if there is no connection to the local public transport receiver.

In this case, please check the connection or whether the local public transport receiver is in programming mode.

10.7 Feedback window

This window shows all commands sent to or from the local public transport receiver.

10.7.1 Clear feedback window

Click on  to clear the contents of the feedback window.

10.8 Transmission display

A progress bar appears for visual control at the bottom of the mask on the left every time data is transferred to or from the local public transport receiver. It disappears again after successful data transmission.

11. Annex

11.1 Calculation example for entering a bottleneck system

Step 1:

Start Ampeltools. Select the required controller type and version in the main window. Fill in the details for the specific construction site in **General data**.

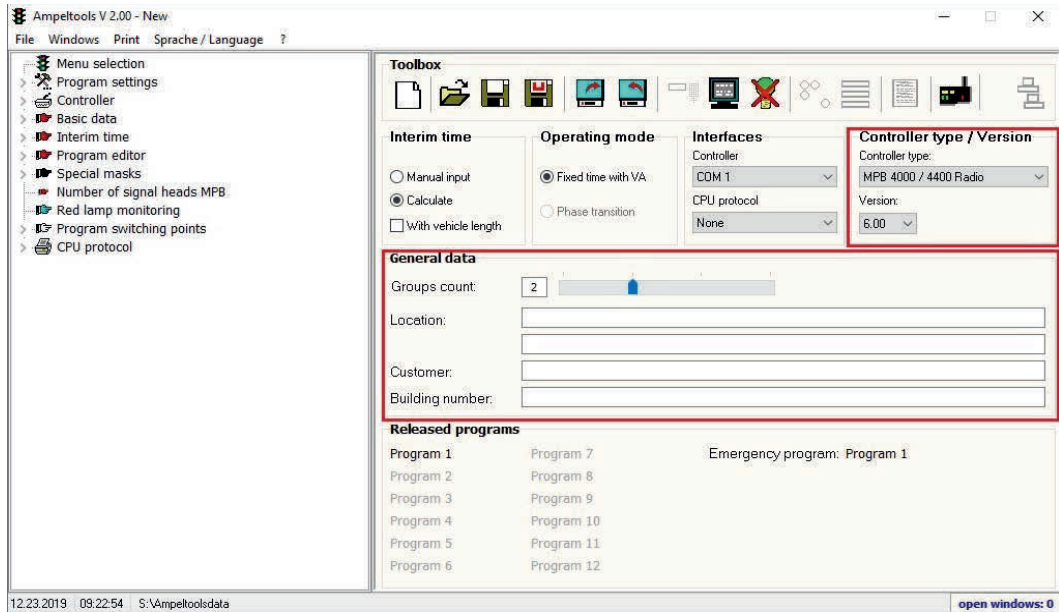

Step 2: Open General data.

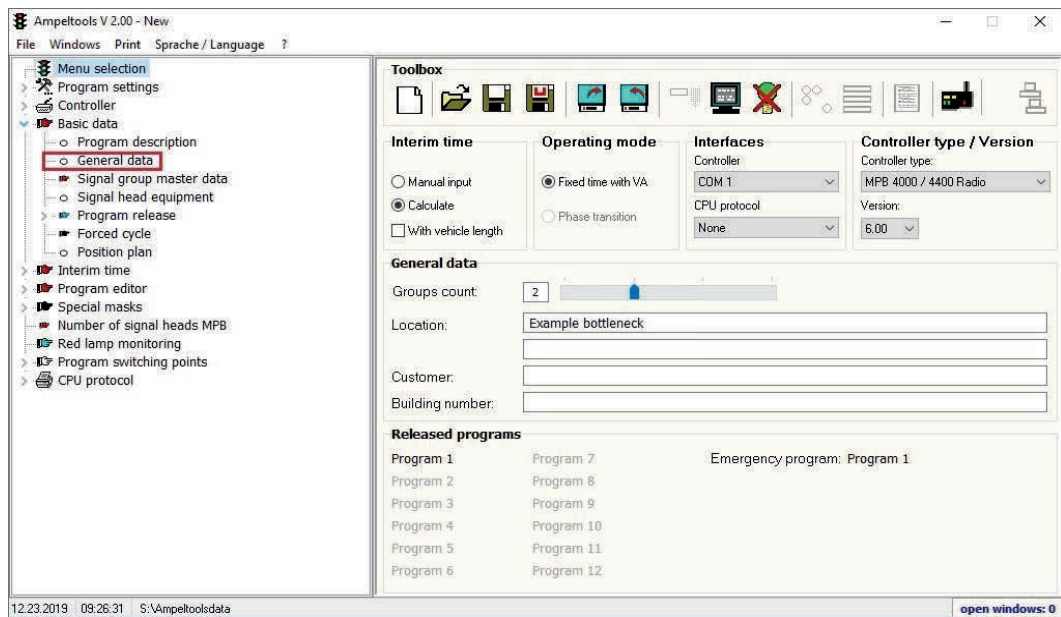

Fill in the details for the specific construction site in the input boxes.

See 6.1.2 for a detailed description.

Step 3: Open Signal group master data

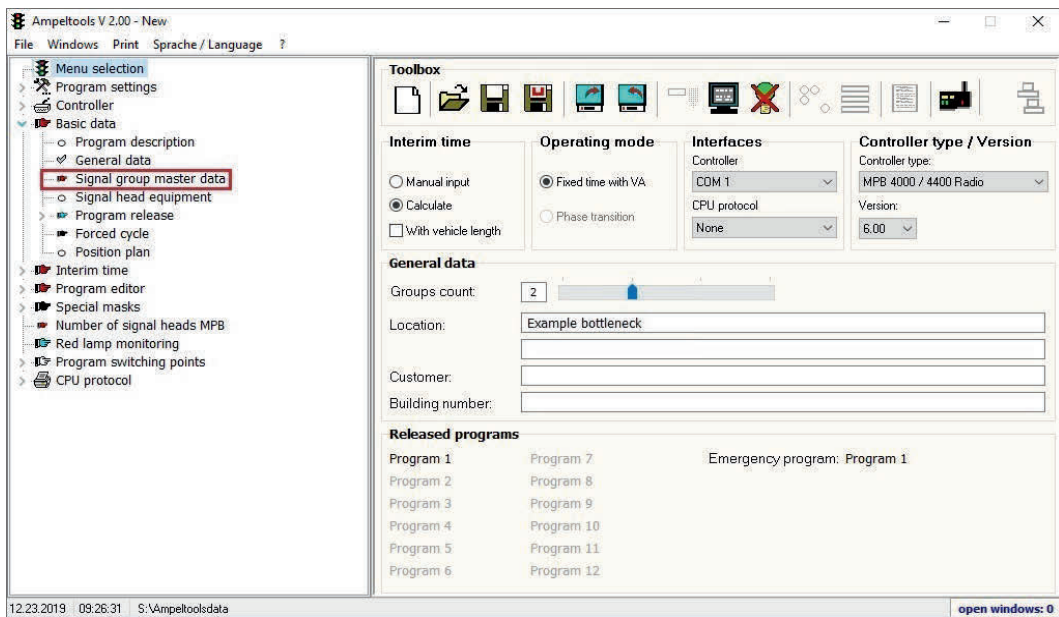

Enter the signal group name, red-yellow, yellow, minimum release times and calculation parameters for every signal group. The details should be entered according to the RiLSA or as required by the responsible authority. Tick **Flashing** for those groups that should switch to a yellow flashing light in the event of a fault or when selected.

Designation	Signal groups type	Red-yellow	Yellow	Min. Release	Clearance speed	Passage time	Entry speed	Vehicle length (m)	Flashing	Request	Transition time with lights off
Signal group 1 K1	Car, truck, bus	1	4	10	30 km/h (8,333 m/s)	4	40 km/h (11,111 m/s)	0	<input checked="" type="checkbox"/>	<input type="checkbox"/>	None
Signal group 2 K2	Car, truck, bus	1	4	10	30 km/h (8,333 m/s)	4	40 km/h (11,111 m/s)	0	<input checked="" type="checkbox"/>	<input type="checkbox"/>	None
Signal group 3	Car, truck, bus	1	4	10	30 km/h (8,333 m/s)	4	40 km/h (11,111 m/s)	0	<input type="checkbox"/>	<input type="checkbox"/>	None
Signal group 4	Car, truck, bus	1	4	10	30 km/h (8,333 m/s)	4	40 km/h (11,111 m/s)	0	<input type="checkbox"/>	<input type="checkbox"/>	None
Signal group 5	Car, truck, bus	1	4	10	30 km/h (8,333 m/s)	4	40 km/h (11,111 m/s)	0	<input type="checkbox"/>	<input type="checkbox"/>	None
Signal group 6	Car, truck, bus	1	4	10	30 km/h (8,333 m/s)	4	40 km/h (11,111 m/s)	0	<input type="checkbox"/>	<input type="checkbox"/>	None
Signal group 7	Car, truck, bus	1	4	10	30 km/h (8,333 m/s)	4	40 km/h (11,111 m/s)	0	<input type="checkbox"/>	<input type="checkbox"/>	None
Signal group 8	Car, truck, bus	1	4	10	30 km/h (8,333 m/s)	4	40 km/h (11,111 m/s)	0	<input type="checkbox"/>	<input type="checkbox"/>	None

See 6.1.3 for a detailed description.

Step 4: Open Signal head equipment

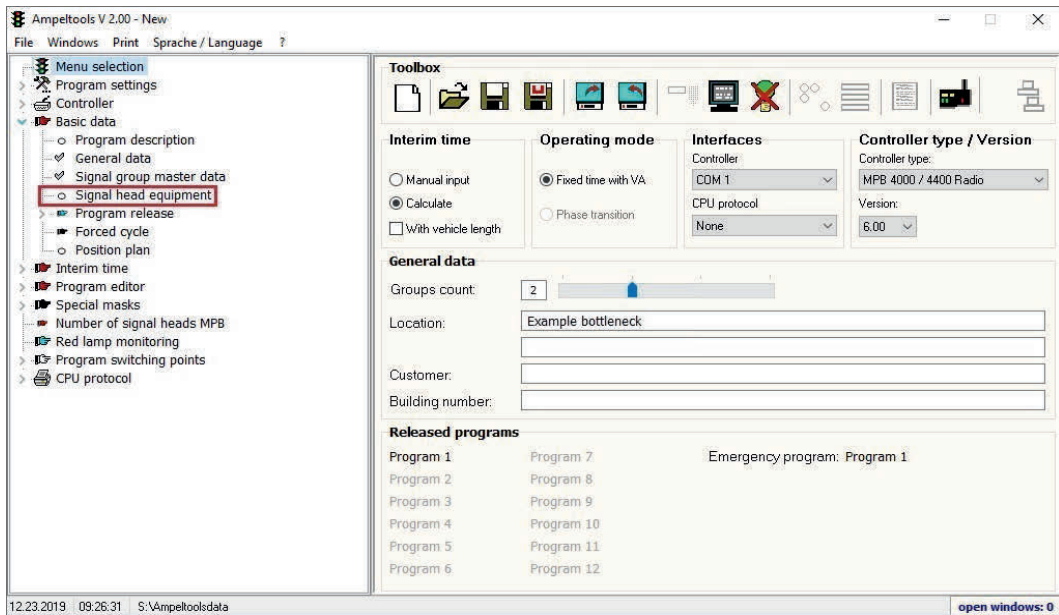

Select the respective equipment for every signal group.

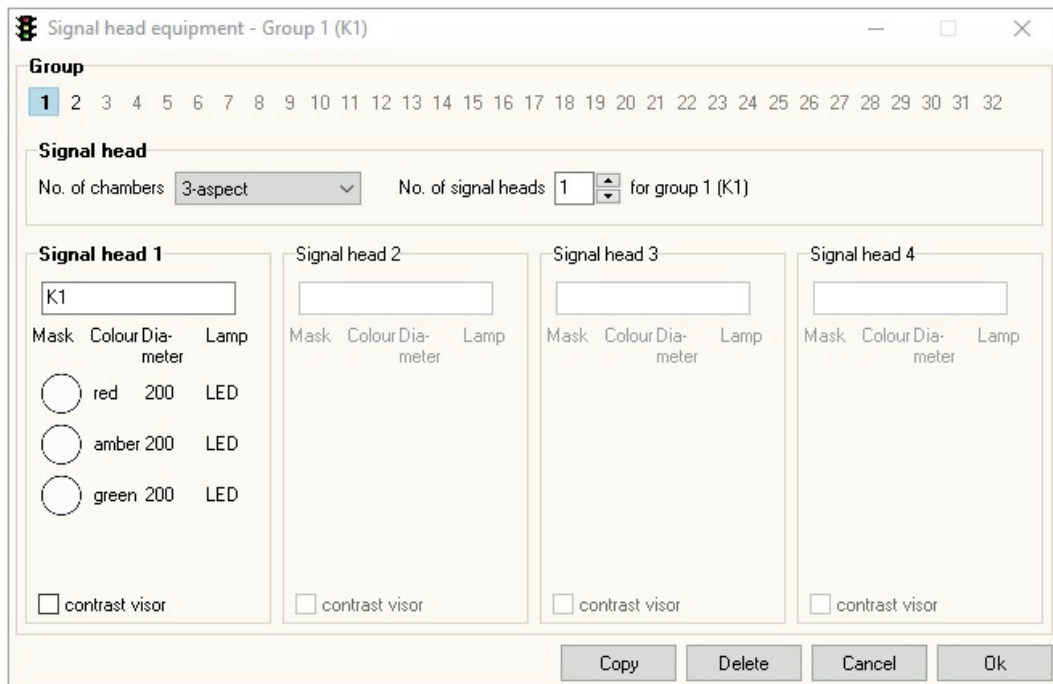

See 6.1.4 for a detailed description.

Step 5: Open Interlocking matrix

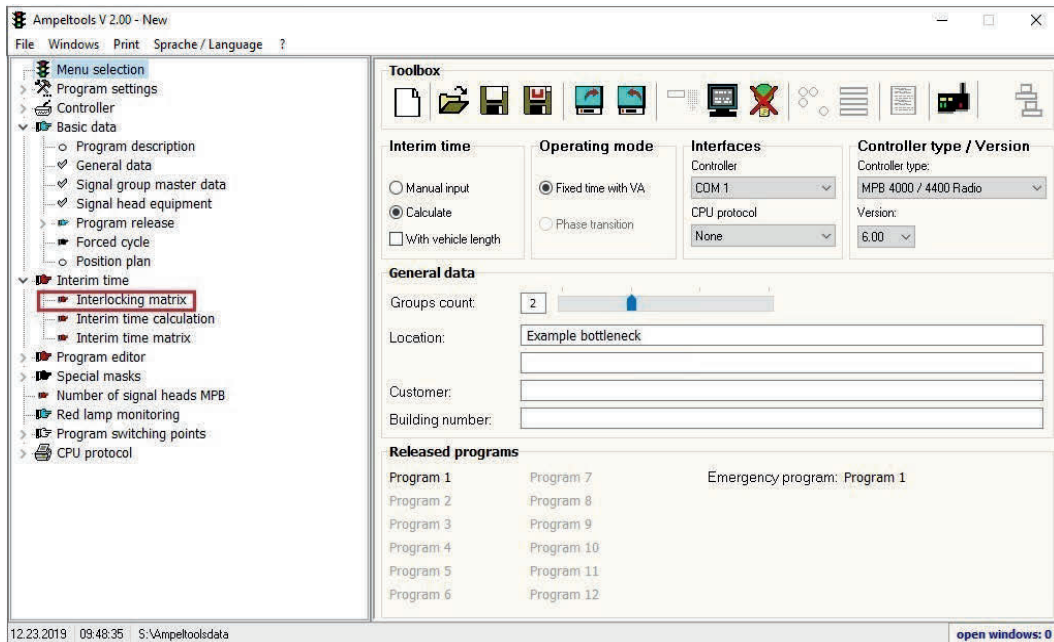

Do a double click with the left mouse button on those signal groups that are hostile to each other. The interim times are then calculated in each case.

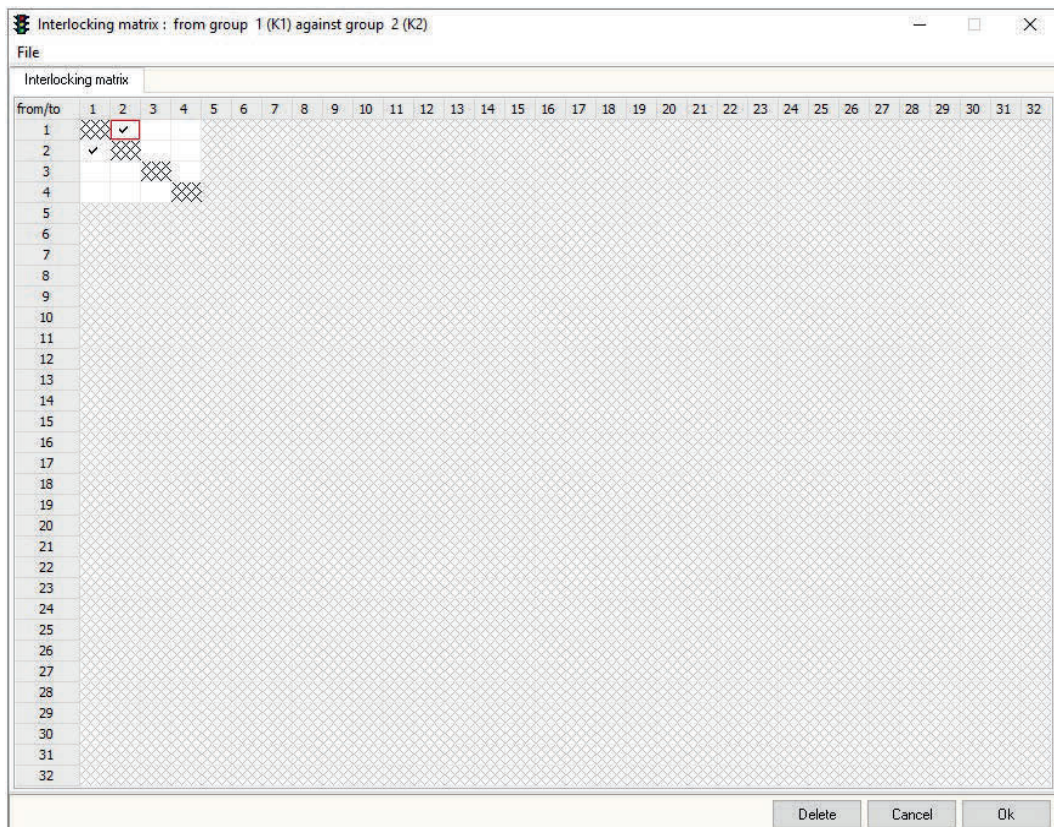

See 6.2.1 for a detailed description.

If data in this mask have been changed, a query appears when you close the mask whether the calculation mask should be opened. Please confirm with **OK**.

Step 6:

If **Interim time calculation** has not opened automatically, open it now manually.

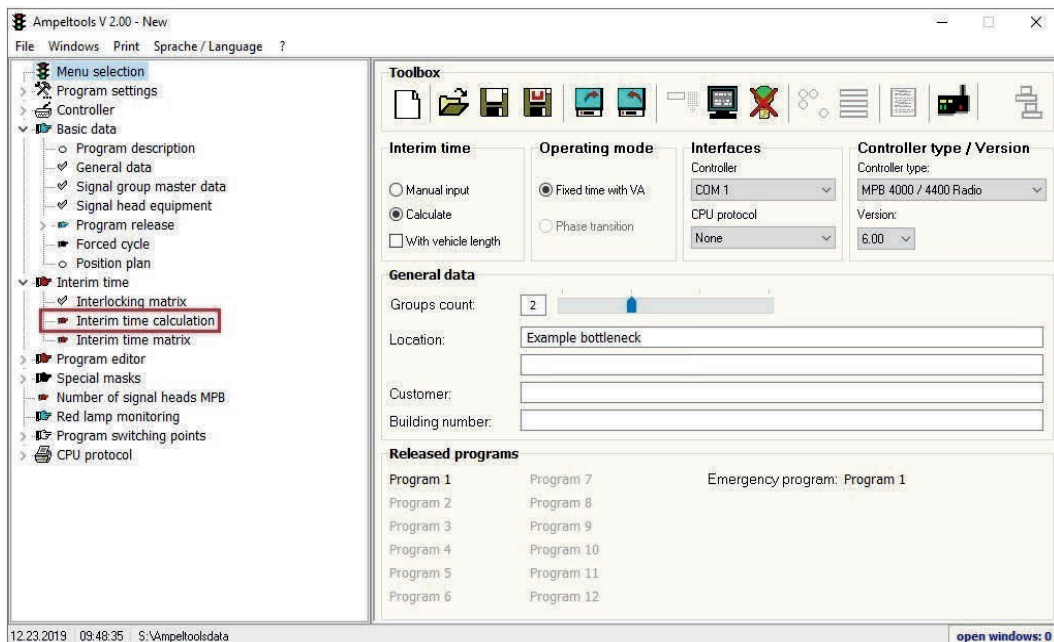

Enter the necessary data for interim time calculation for each clearance.

The calculation parameters are preset from the signal group master data, but can be adapted for every clearance. In certain circumstances, cyclists have to be taken into consideration so that other clearance speeds have to be chosen.

It may be necessary to consult the responsible authority here.

Interim time calculation according to RiLSA															
Signal device designation				Clearance time (tr)				Entry time			Tü	Interim time			
No.	End Green	Lane ID (C)	Start Green	Lane ID (E)	Crossing distance in meters	Vehicle length in meters	Clearance distance in meters	Clearance speed	Time in sec.	Entry distance in meters	Entry speed	Time in sec.	Crossing time in secs.	Tz calculated in secs.	Tz selected in secs.
1	K1		K2		100,00	0	100,00	30 km/h	12,000	0,00	40 km/h	0,000	4	16,000	16
2	K2		K1		100,00	0	100,00	30 km/h	12,000	0,00	40 km/h	0,000	4	16,000	16

See 6.2.2 for a detailed description.

If closed with **OK**, the interim time matrix is produced automatically.

Step 7: Open Interim time matrix

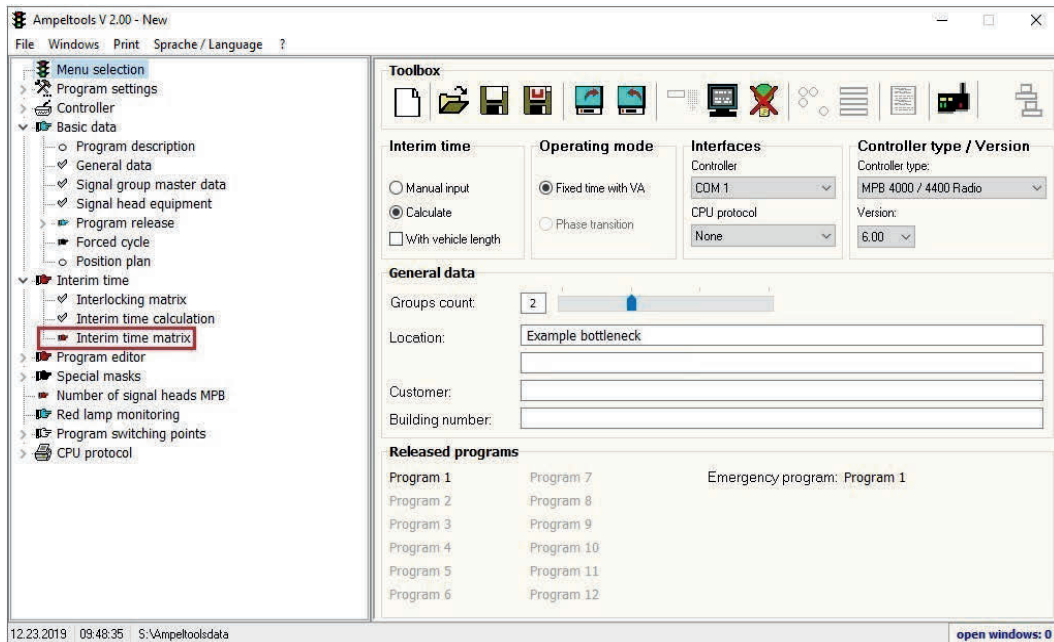

Here you can check the values taken from the interim time calculation. It is not possible to change them here.

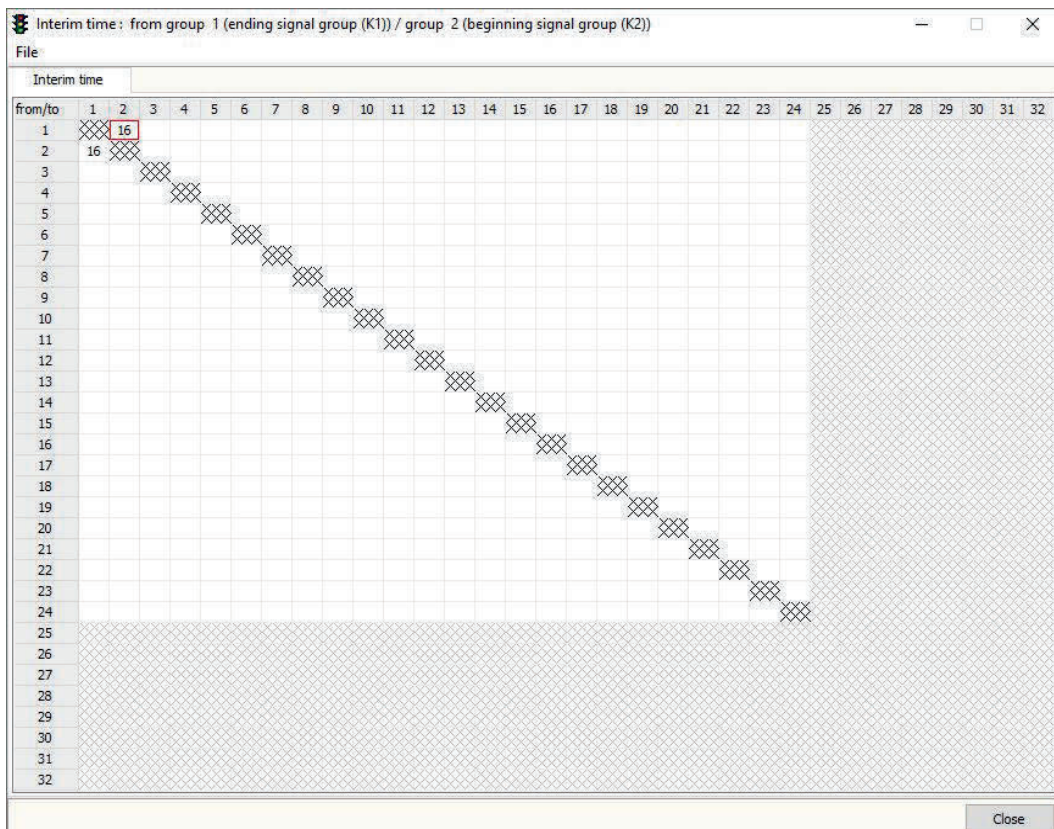

See 6.2.2 for a detailed description.

Step 8:
Open Intersection time plan editor

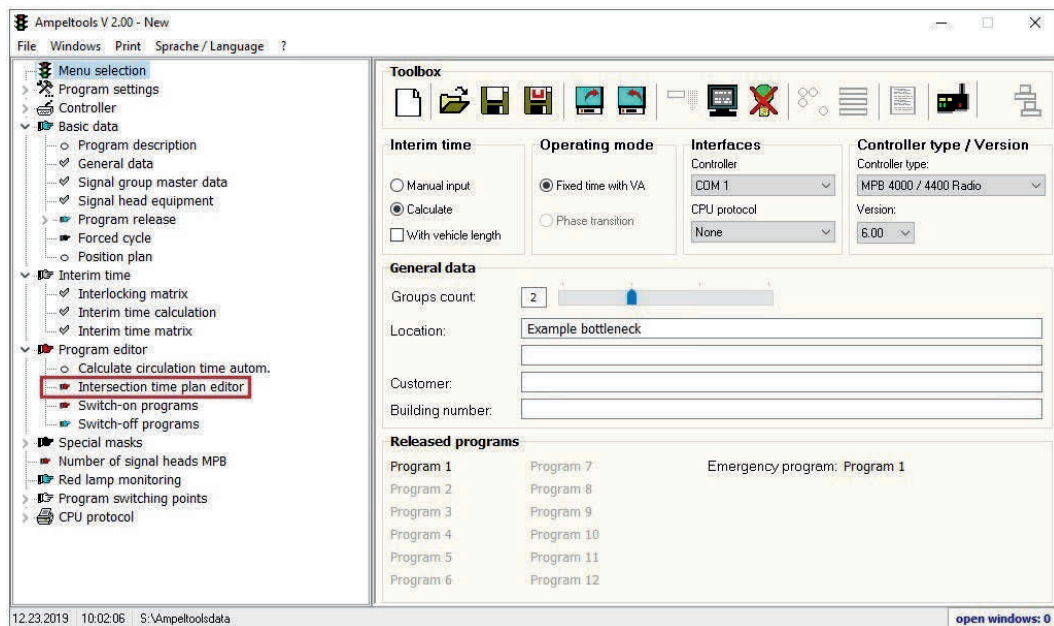

Depending on the program setting, a query appears whether the intersection time plan should be based on traffic volumes.

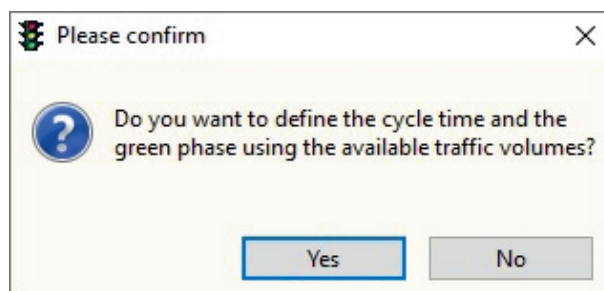

Only confirm this query with **Yes** if traffic volumes are available. Otherwise, ignore this point and continue with **Step 9**.

Step 8:
Enter the traffic flow in **Traffic flow**. The program then ascertains the best program according to the formula RiLSA 2015 Bottleneck Systems.

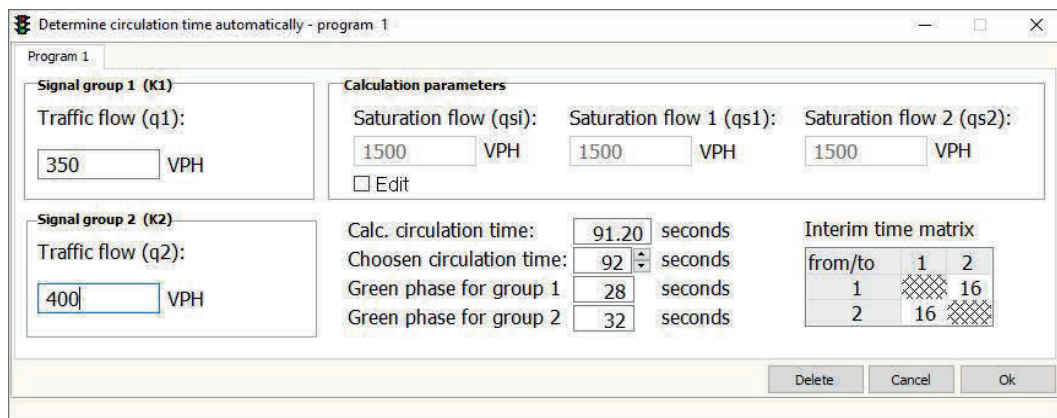

See 6.3.1 for a detailed description.

If you close with **OK**, the following query asks which intersection time plan should be automatically created.

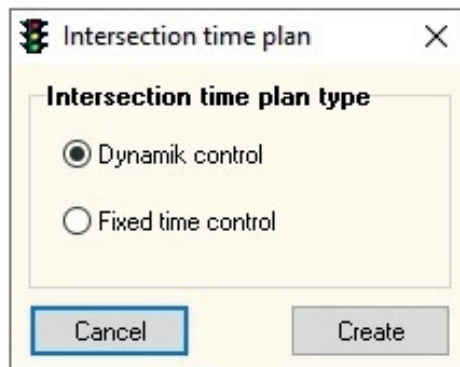

The image shows a dialog box titled "Intersection time plan" with a close button (X) in the top right corner. The dialog contains a section titled "Intersection time plan type" with two radio button options: "Dynamik control" (which is selected) and "Fixed time control". At the bottom of the dialog, there are two buttons: "Cancel" and "Create".

Either a fixed phase program (fixed cycle) or vehicle-actuated program (variable cycle) is created depending on the confirmation.
See 6.3.1.3 for a detailed description
Continue then with **Step 11**.

Step 9: Intersection time plan editor

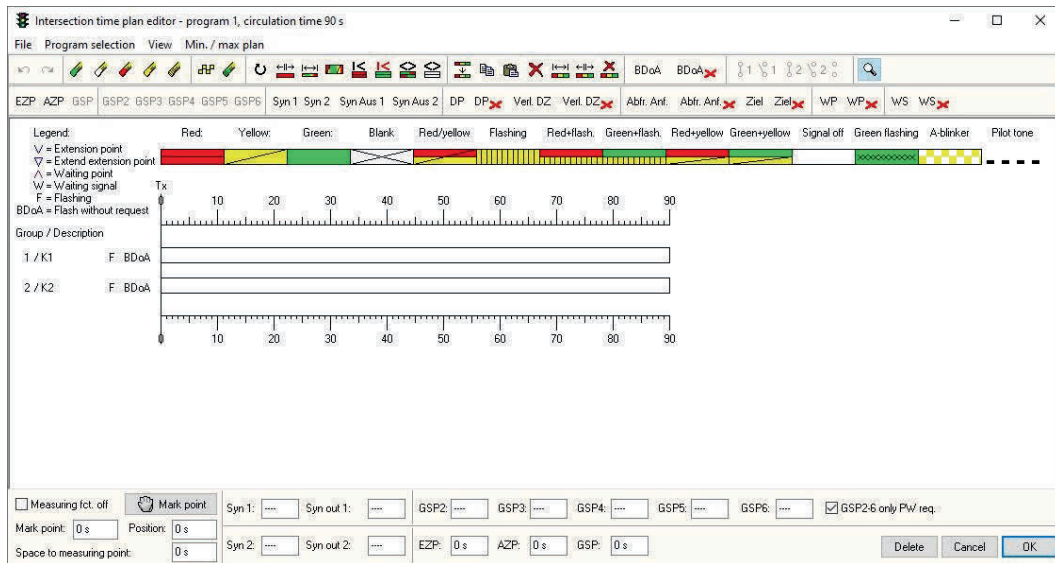

Create the minimum intersection time plan manually (see 6.3.4.1) or using the automatic function (see 6.3.5.7).

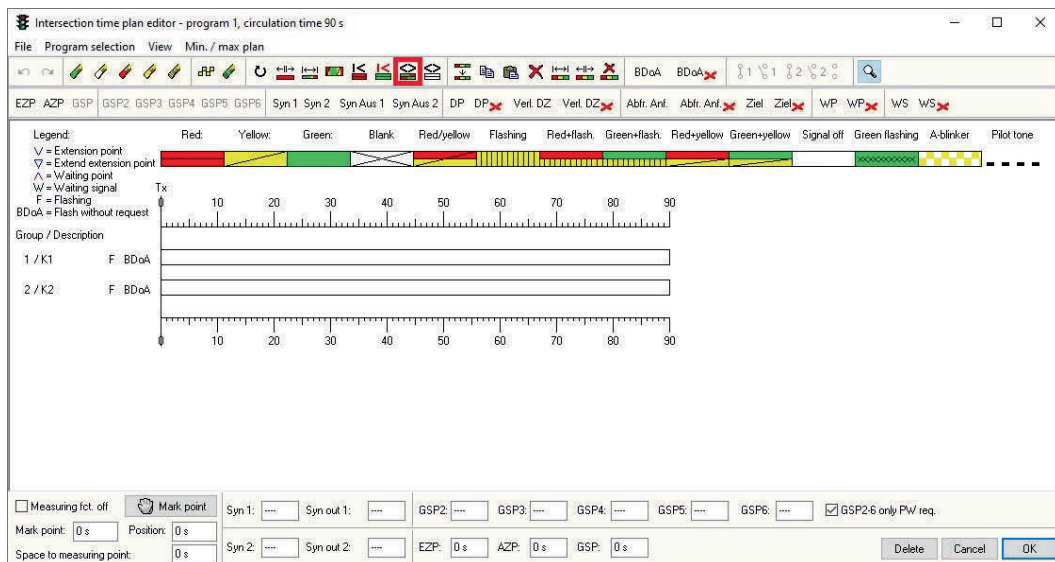

See 6.3.3 / 6.3.4 for a detailed description.

Step 10:
 Add vehicle actuation
 Click on **DP**

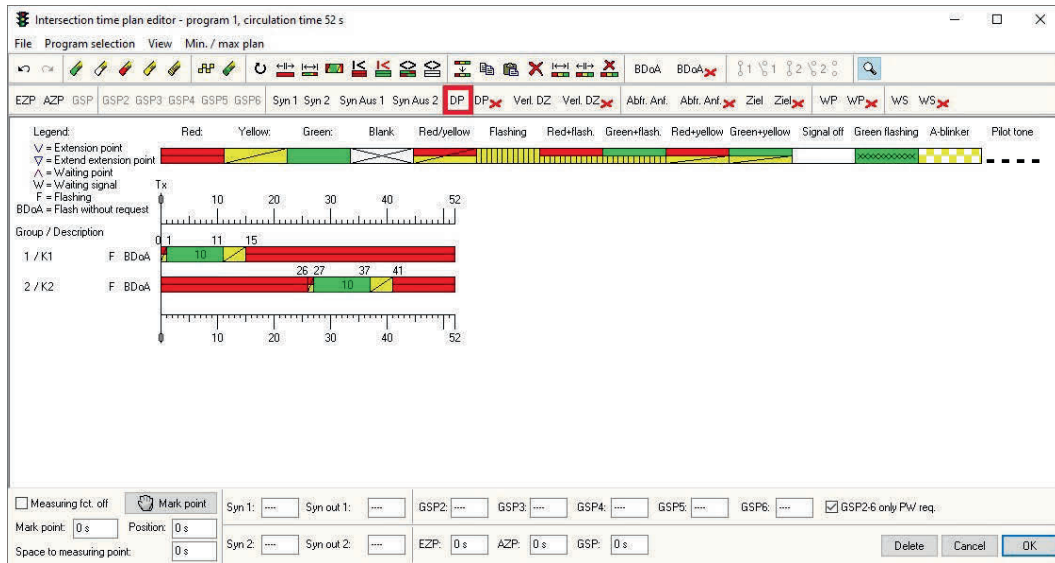

With the left mouse button, position the extension point one second before the end of the green phase in the first signal group.

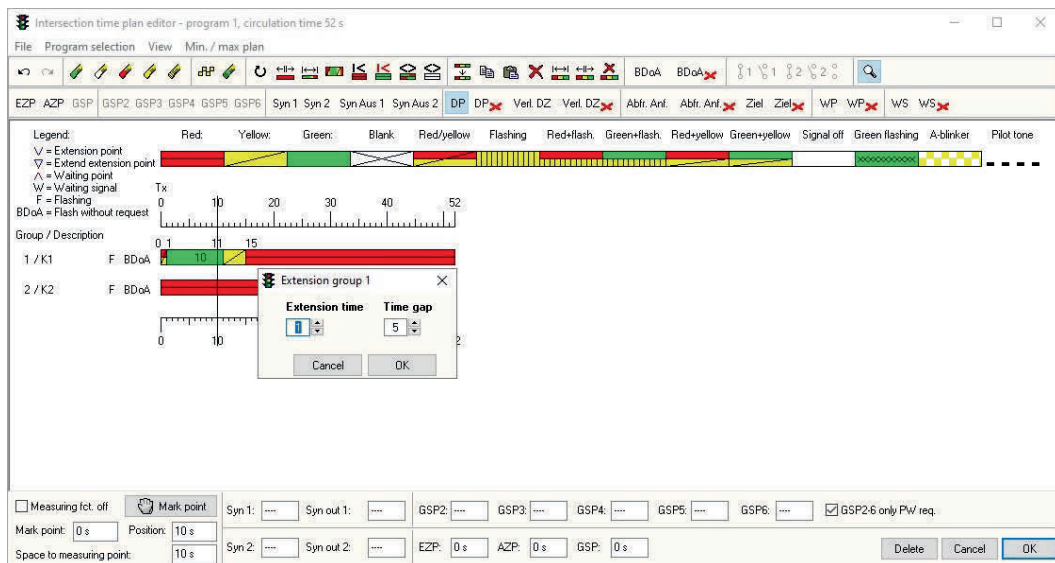

Enter the values for extension Synn time and time gap in the corresponding window.
 Confirm with **OK**.
 Repeat for the next signal group.

See 6.3.6 for a detailed description.

Step 11:
 Insert ON time
 Click on **EZP**

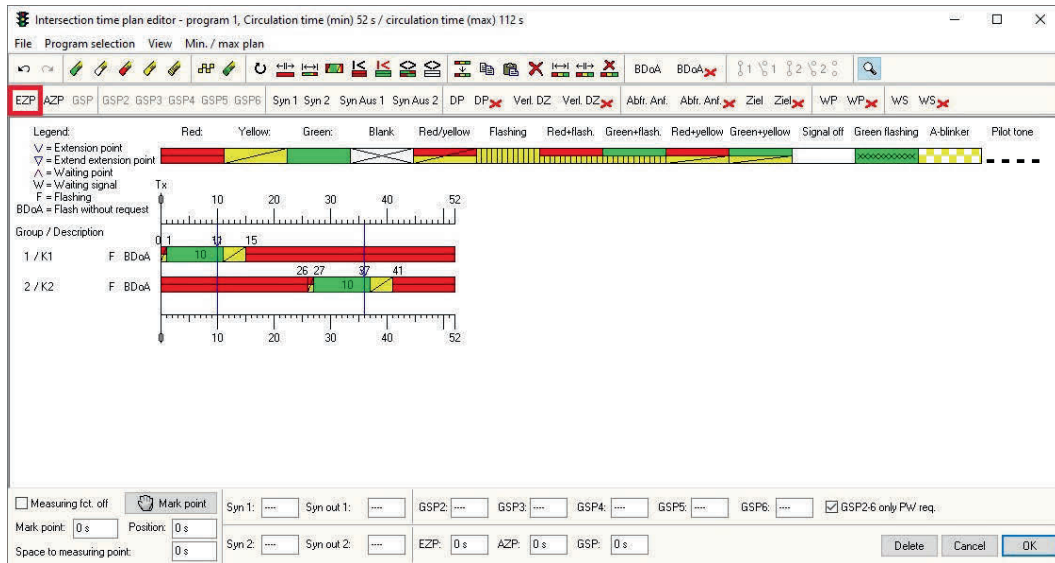

Mark the required ON time by clicking the mouse in the required second of the cycle. As a rule, this is always in a continuous red point in the intersection time plan, immediately before red-yellow of a signal group. In the example, this is the second 0. The EZP adjusted in this way is then shown below in the intersection time plan editor.

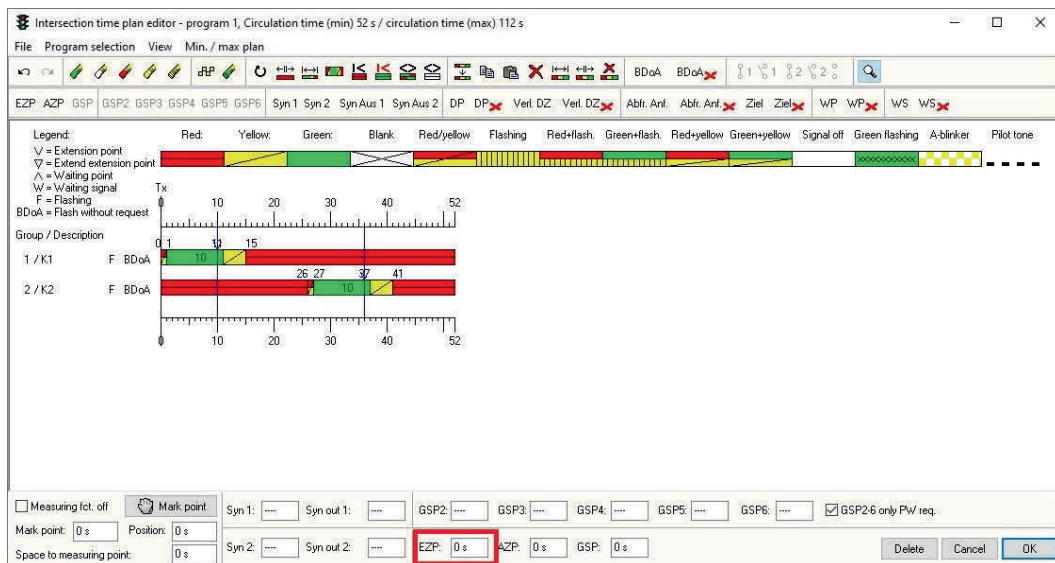

See 6.3.4.8 for a detailed description

Step 12:
Insert OFF time
Click on AZP

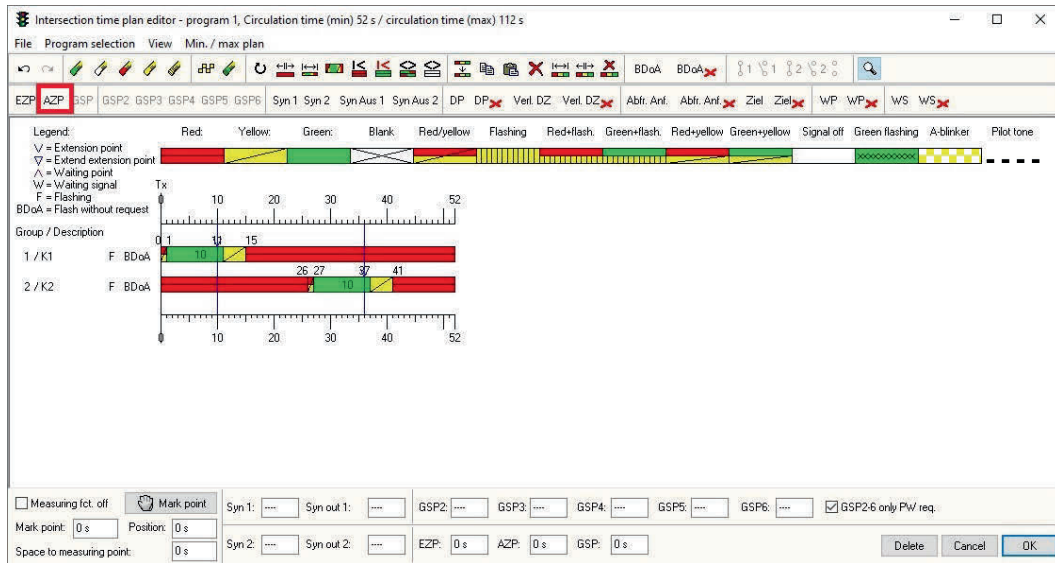

Mark the required OFF time by clicking the mouse in the required second of the cycle. As a rule, this is always in a continuous red point in the intersection time plan. In the example, this is the second 15. The AZP adjusted in this way is then shown below in the intersection time plan editor.

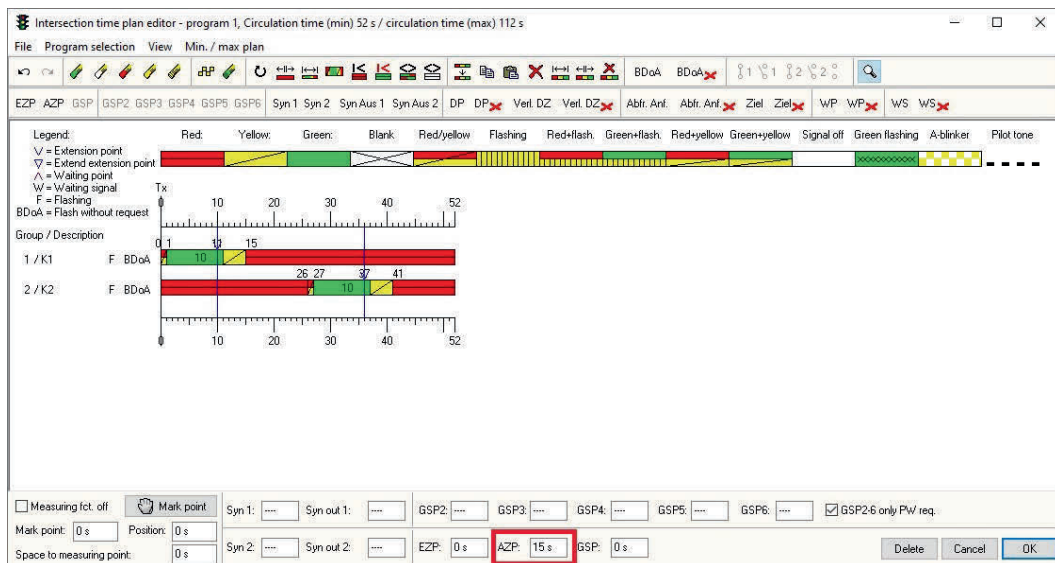

See 6.3.4.9 for a detailed description

For controller type MPB4xxx, a message about checking signal safeguarding appears on closing the mask.

Here you can check the preset red lamp monitoring function, adjust if necessary and close with **OK**.

Prg./Grp.	1	2	3	4	5	6	7	8	9	10	11	12	13	14	15	16	17	18	19	20	21	22	23	24
P1	<input checked="" type="checkbox"/>	<input checked="" type="checkbox"/>																						
P2																								
P3																								
P4																								
P5																								
P6																								

Buttons: Delete, Cancel, Ok

See 6.6.4 for a detailed description.

Step 13: Open Switch-on programs

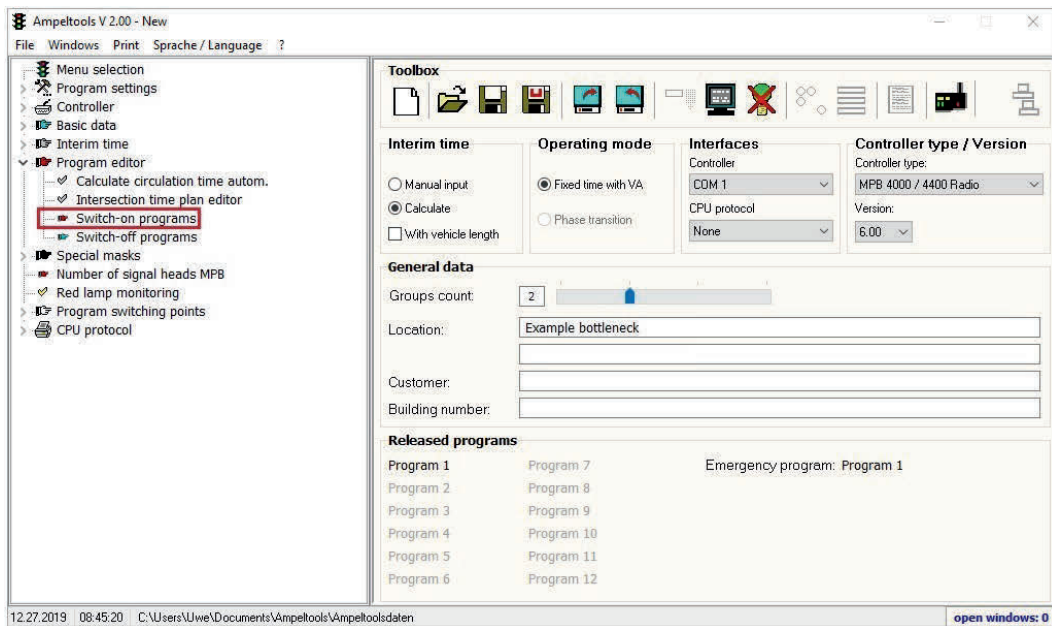

Enter step time **4** for step 1. For step 2, enter the highest value from the interim time matrix shown to you as "Longest interim time in matrix". Nothing is entered for step 3. These defaults correspond to a switch-on program according to RiLSA 2015 Bottleneck Systems. However, if the responsible authority specifies another switch-on program, please adjust the ON point accordingly.

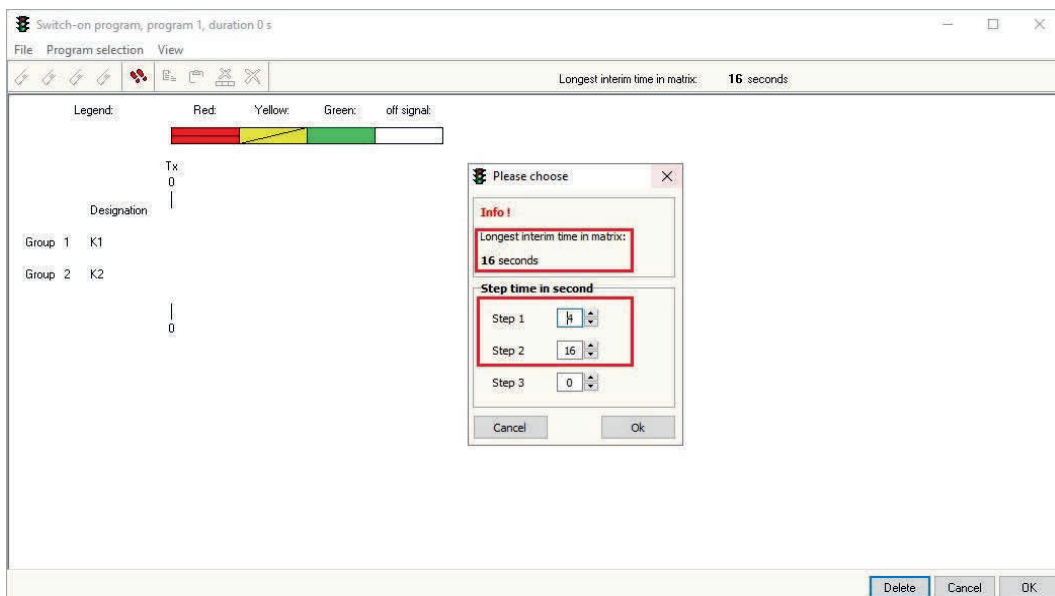

Confirm with **OK** to open the switch-on program editor. This has two areas according to the step time, separated by a dividing line.

The first 15 seconds from the ON time of the signal program are shown in the right area.

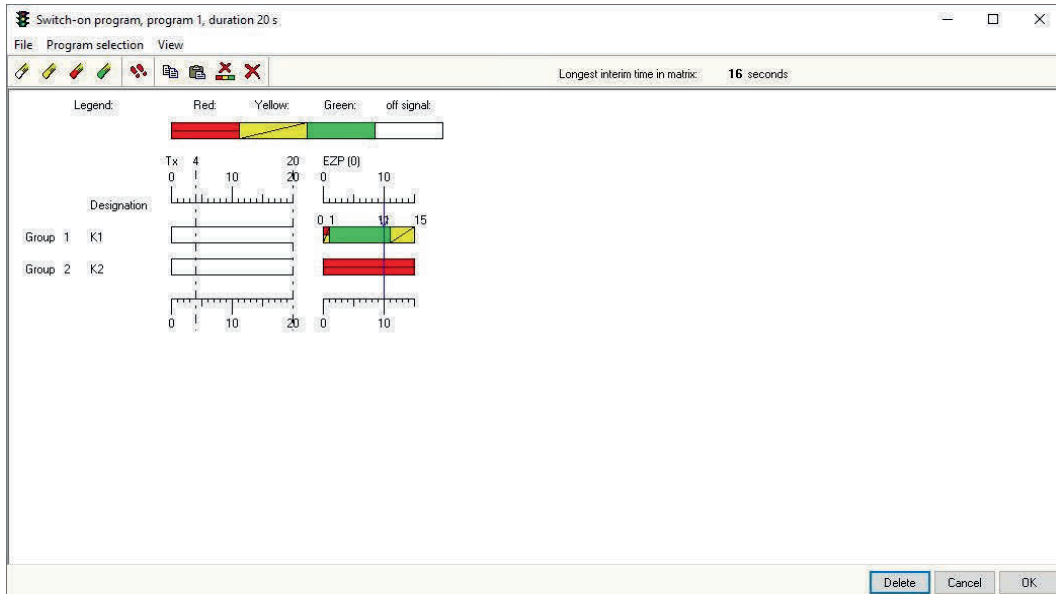

Select the yellow paintbrush with the left mouse button, then click in the first step marking for both signal groups one after the other. They change colour to yellow. Then select the red paintbrush and click in the second step marking for both signal groups one after the other. They change colour to red.

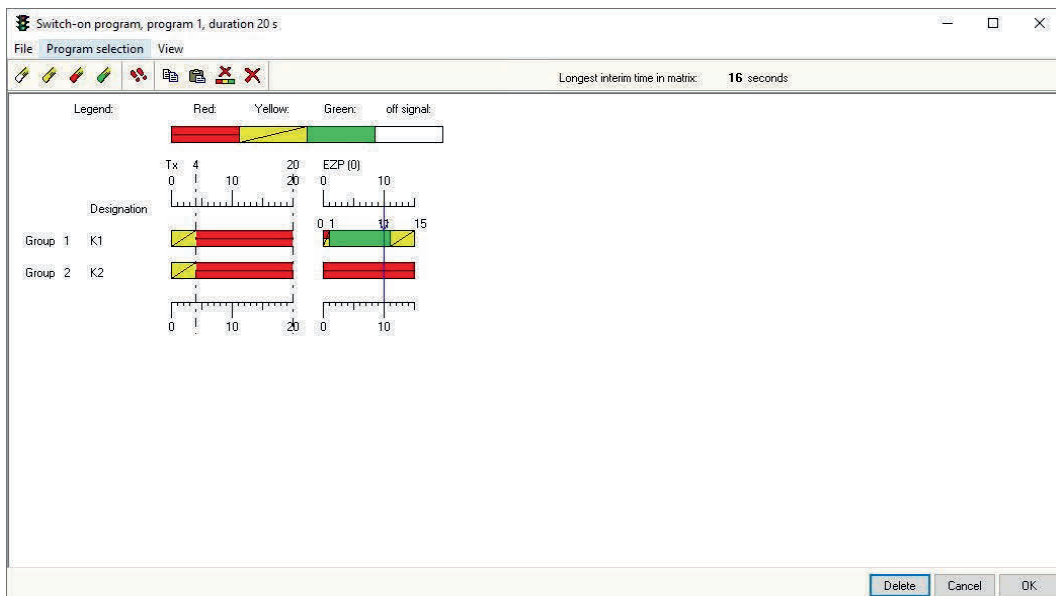

After creating the switch-on program, this (left area) should move on seamlessly to the ON point of the signal program (right area)
See 6.3.8 / 6.3.8.4 for a detailed description.

Step 14: Open Switch-off programs

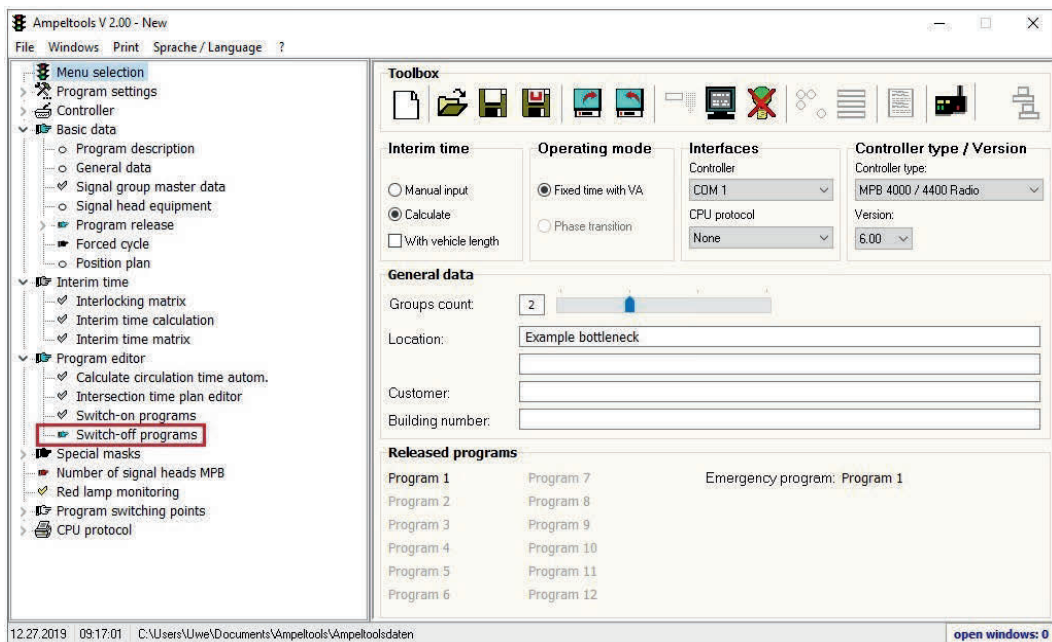

As step time, enter the highest value from the interim time matrix shown to you as "Longest interim time in matrix". Nothing is entered for the two other steps.
 RiLSA 2015 has no defined switch-off patterns for bottleneck traffic light systems. There is only one example for possibly switching off with continuous red.
 It may be necessary to consult the responsible authority here, in which case the OFF point may have to be adjusted.

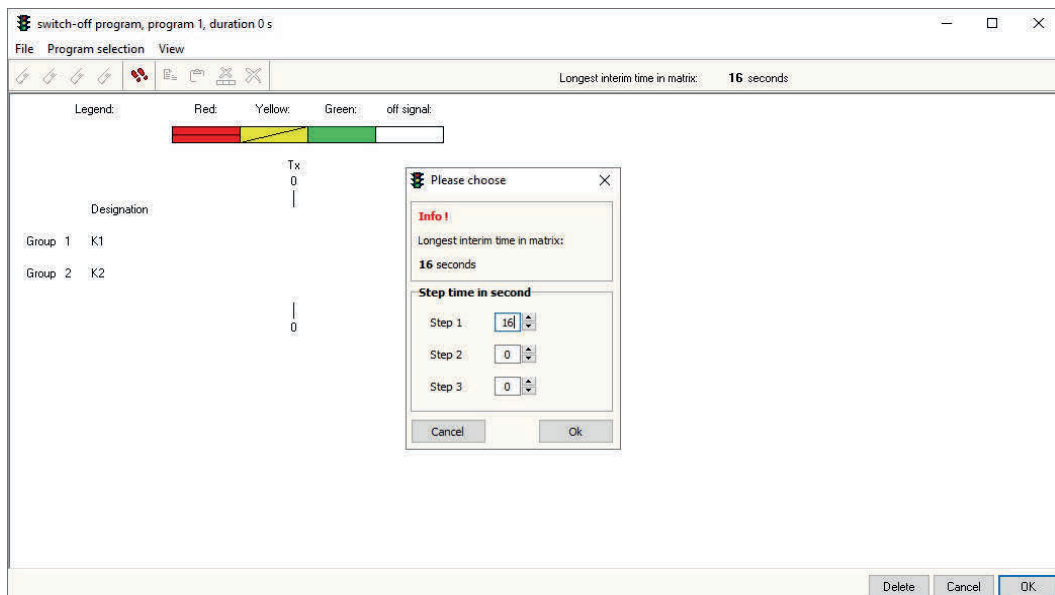

Confirm with **OK** to open the switch-off program editor.

The last 15 seconds from the OFF time of the signal program are shown in the left area.

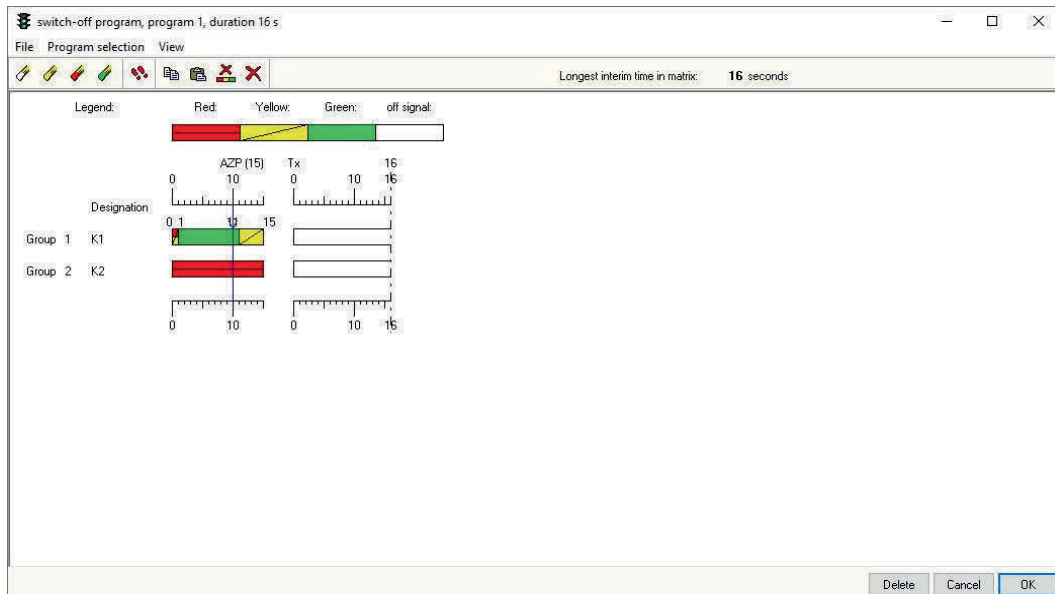

Select the red paintbrush with the left mouse button, then click in the step marking for both signal groups one after the other. They change colour to red.

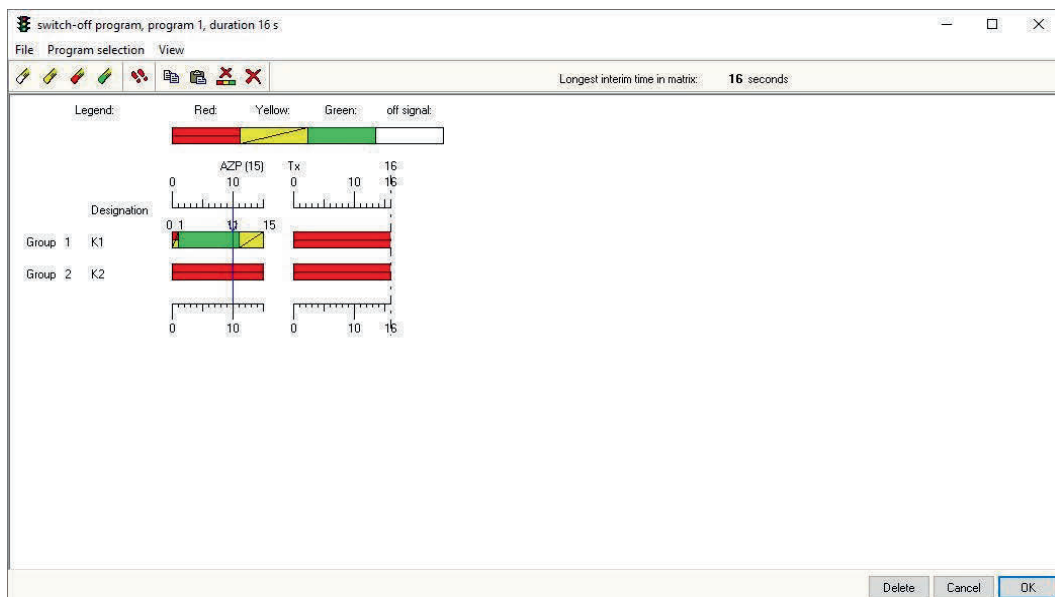

After creating the switch-off program (right area), this should move on seamlessly to the signal program (left area)

See 6.3.9 for a detailed description.

Step 15:
Open Number of signal heads MPB

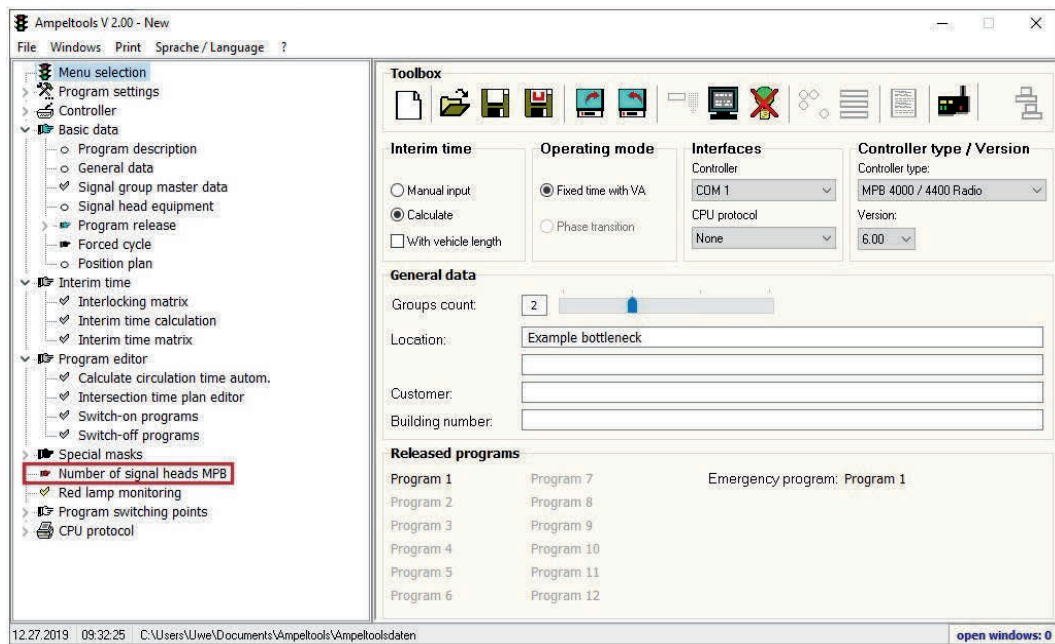

Here you can enter the number of signal heads with controller in each signal group.



See 6.5 for a detailed description.

Step 16:
Save existing data
To save existing data, click on **Save data**.

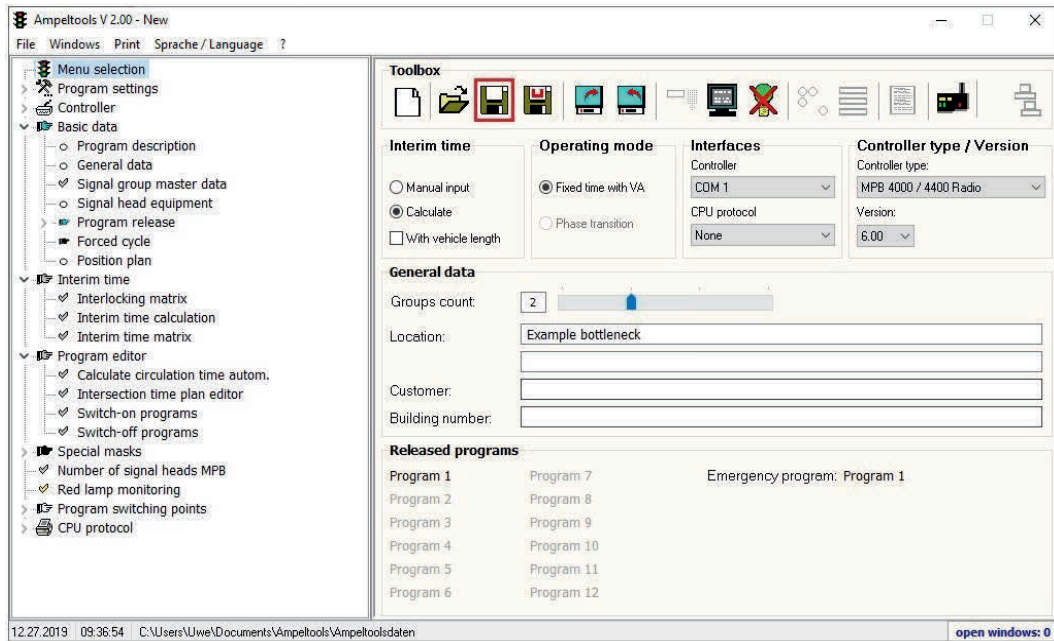

Please enter a file name for saving the program.

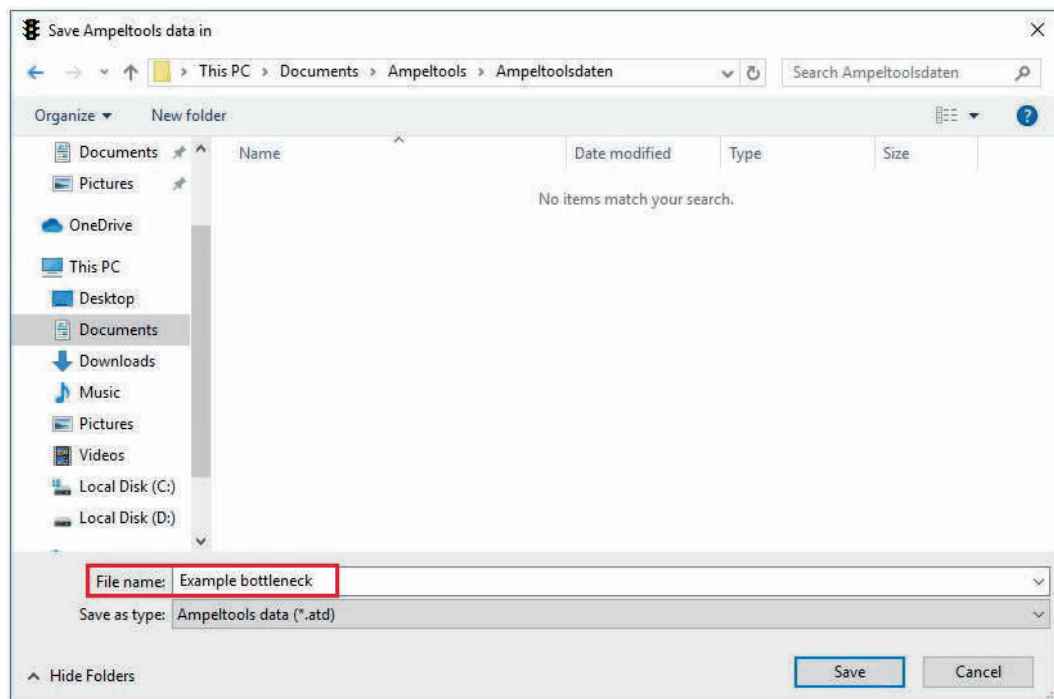

Confirm with **Save**.

The data will be saved accordingly with a corresponding progress bar.

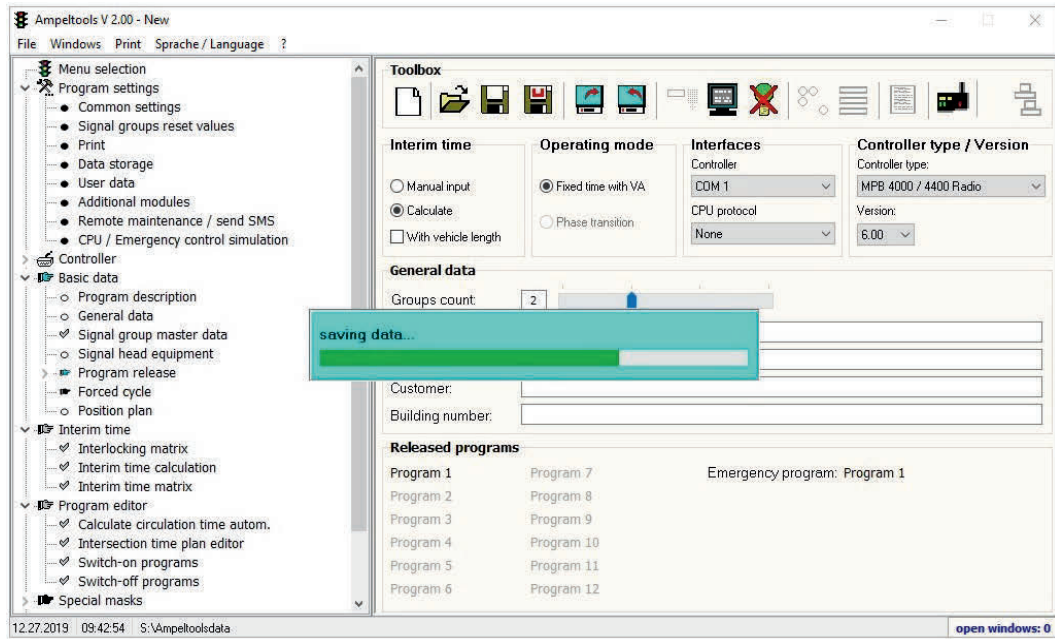

When the data have been saved, the file name appears in the main window.

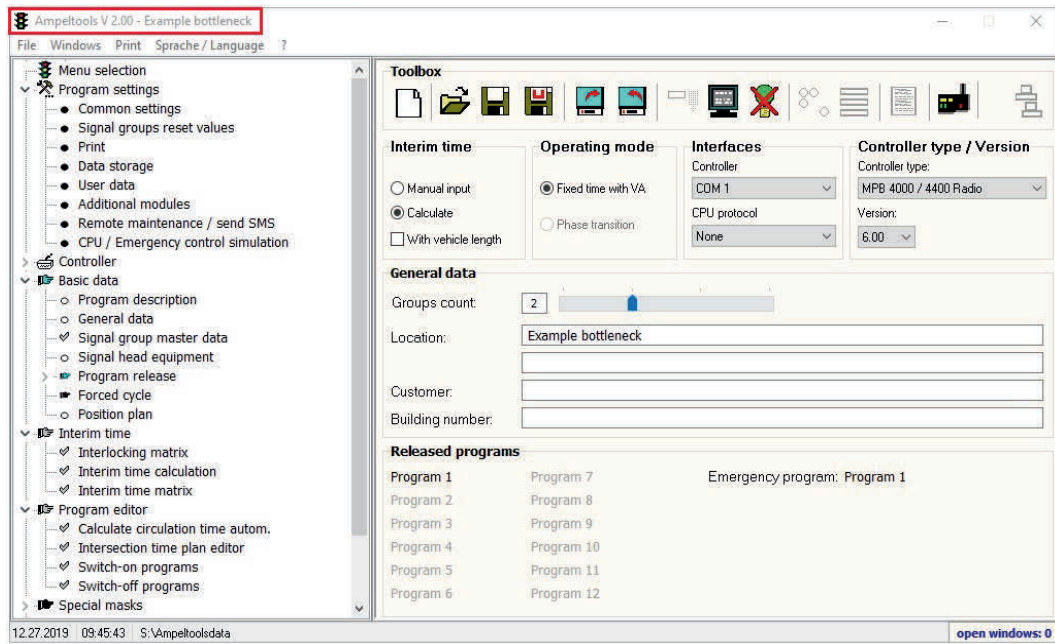

See 4.2.2 / 4.2.3 for a detailed description.

Step 17:

Print existing data

To print existing data, select the required function in the print menu or use **Print all**.

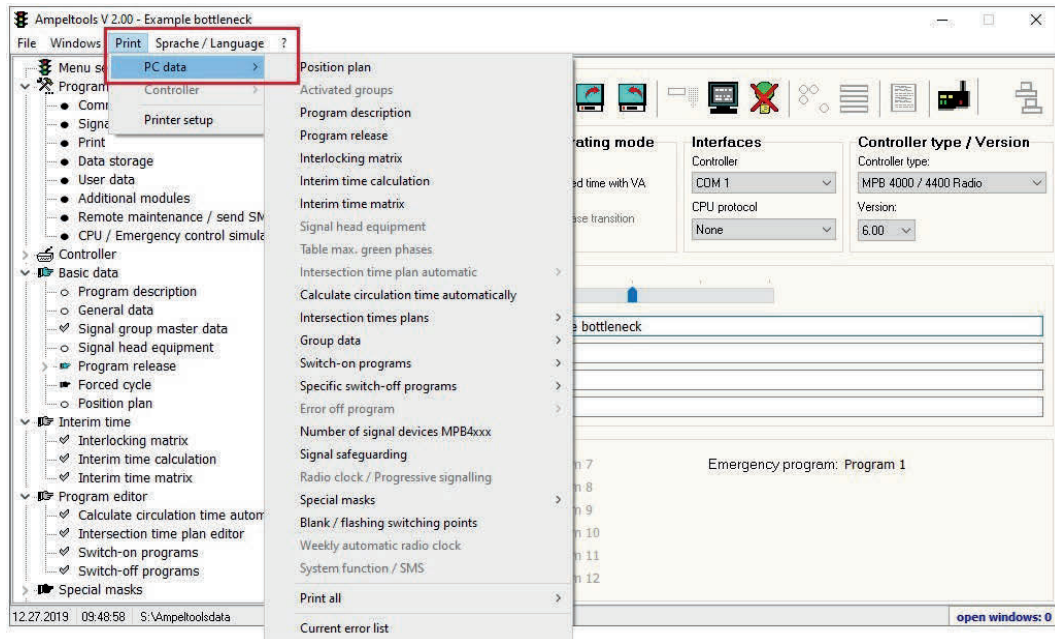

See 4.4.3 / 4.4.3.1.5 for a detailed description.

Step 18:

Data transfer to 12 groups interface

Select the corresponding serial interface for data transfer. If you use a USB serial converter, it should be plugged in before you start Ampeltools. Connect the USB serial converter with the corresponding PC lead and the 12 groups interface.

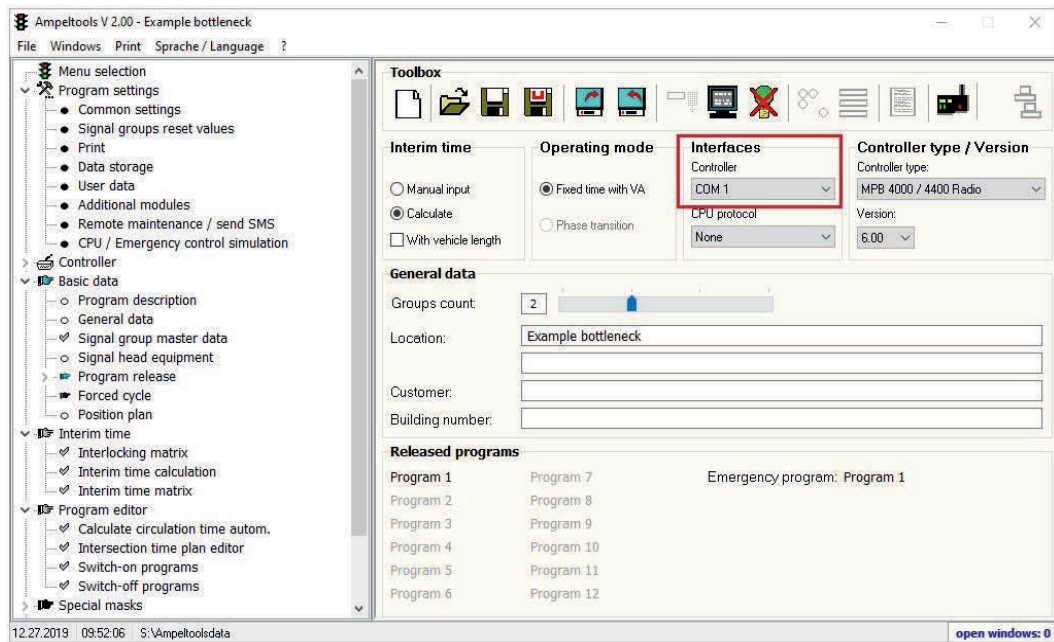

If no interface is selected, all data transfer functions are disabled.

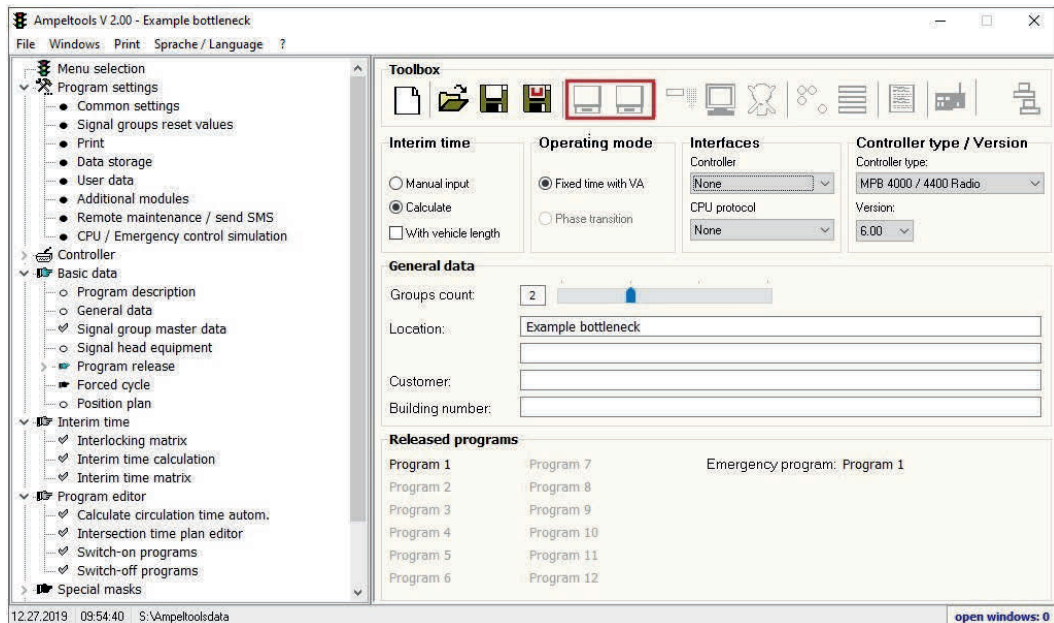

Select the corresponding setting for data reception at 12 groups interface.

Press the corresponding button to start data transfer.

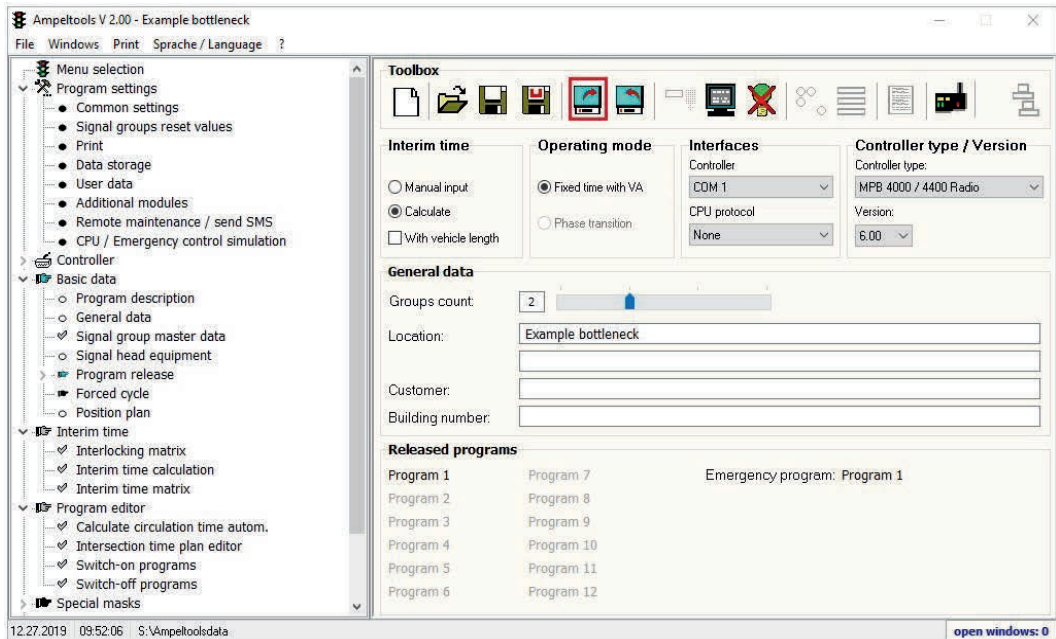

The data transfer window opens.

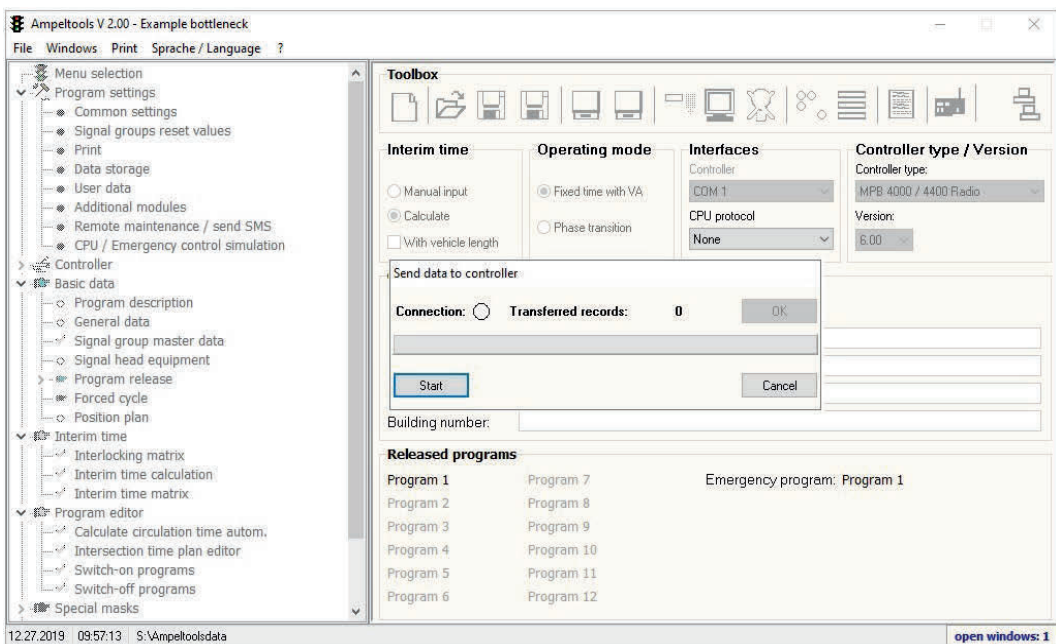

Press **Start** for data transfer to begin.

A progress bar appears while data transfer is active. If you receive an error message instead, please check the connection (controller type, PC lead, COM port, 12 groups interface switched on / correct setting).

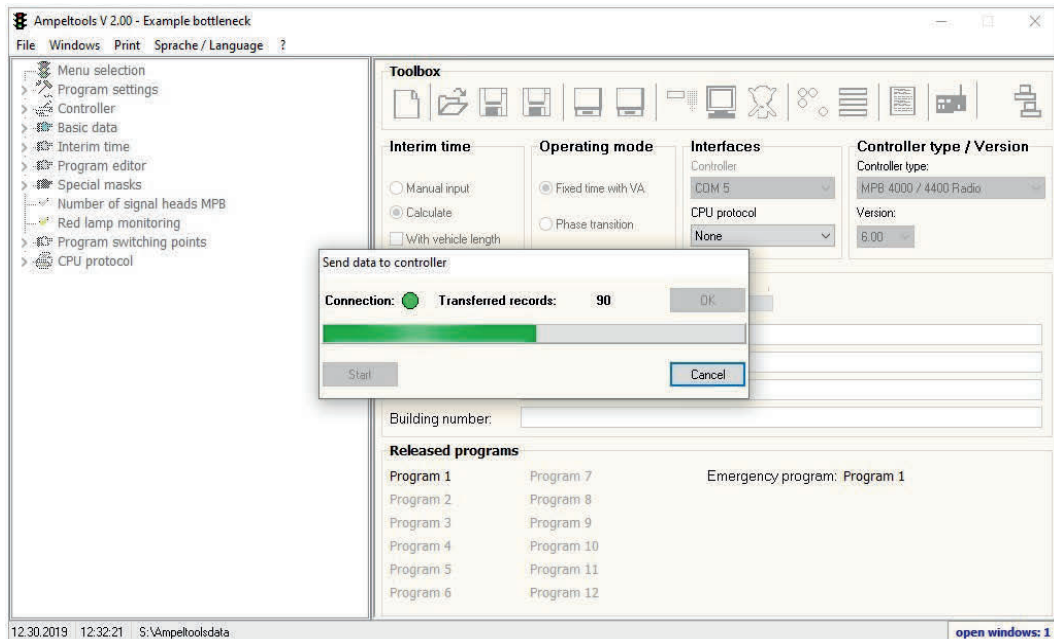

OK is enabled again once data transfer has been completed. Press to close the data transfer window.

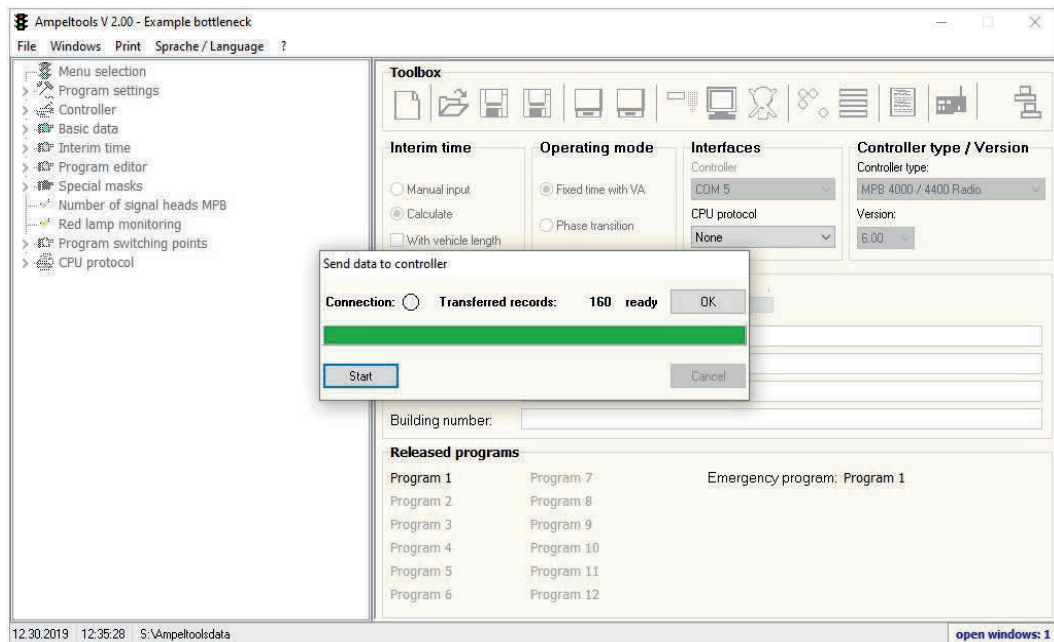

See 4.2.5 for a detailed description of the 12 groups interface manual.

Step 19:

Load saved data

Click on **Load data** to load a saved file.

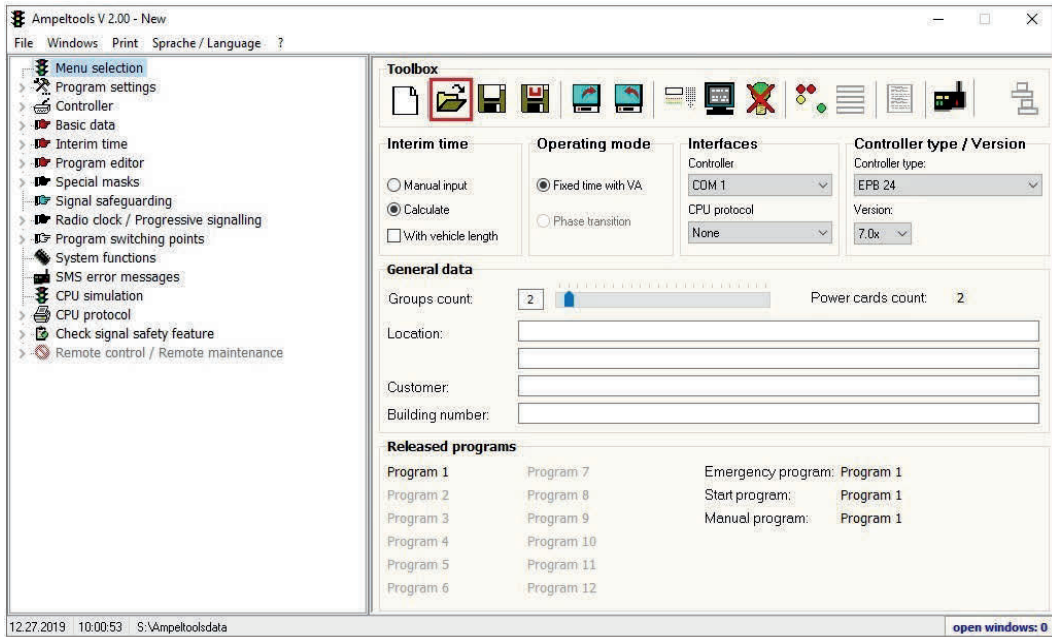

The dialogue box opens and you can select the required file.

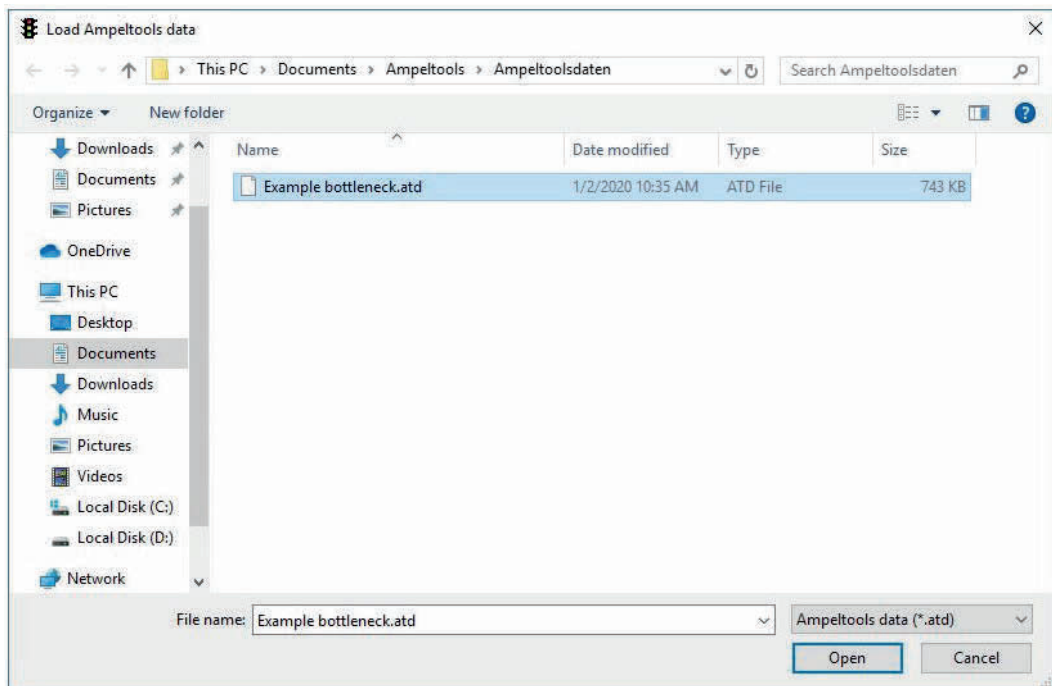

Click on **Open** to start loading the required data; a progress bar appears.

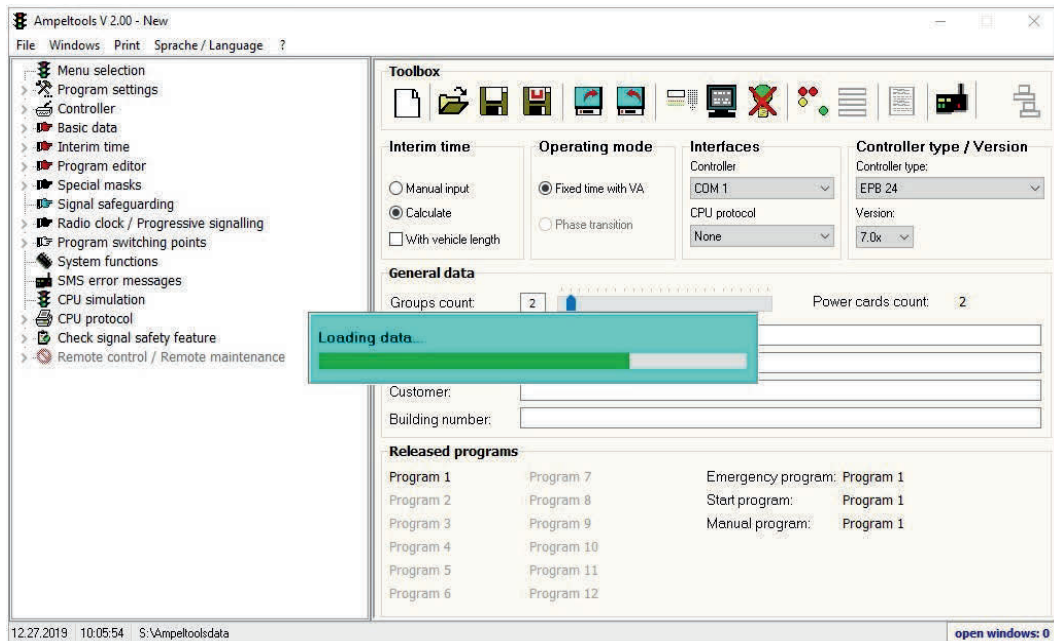

When the data have been loaded, the file name appears in the main window.
The loaded program can now be edited or amended.
See 4.2.2 for a detailed description.

Step 20: Create map

To create a map, please use a corresponding drawing program.
You can use the integrated drawing module if you only want to create a map that is not to scape.
See 6.1.9 for a detailed description.

Step 21: Create new program

Select **New** to create a new program.
Please note that it is possible for all currently existing data or changes to be rejected. Please save these data first. You may possibly see a query whether the existing data should now be saved.

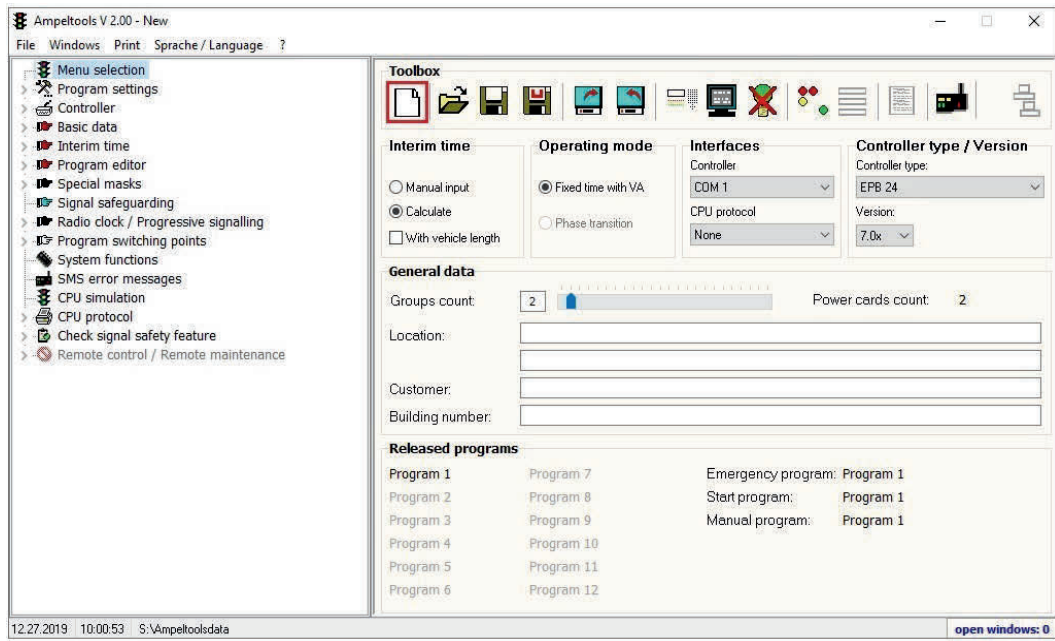

11.2 Calculation example for entering a T-junction system

Step 1:

Start Ampeltools. Select the required controller type and version in the main window. Fill in the details for the specific construction site in **General data**.

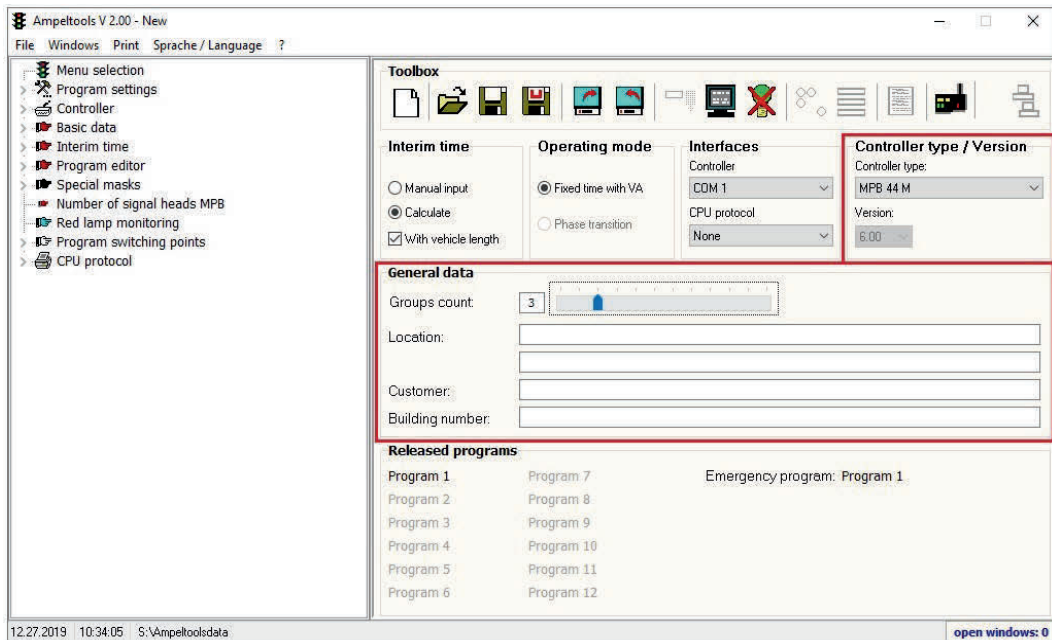

Change the value in **Number of groups** to 3. Confirm the query whether vehicle lengths should be used for calculation with **Yes** and confirm with **OK**.

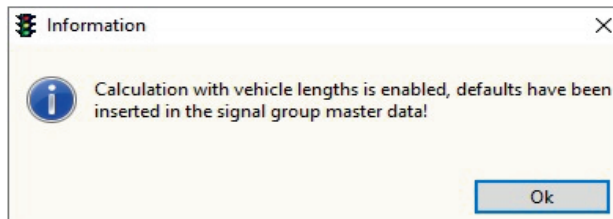
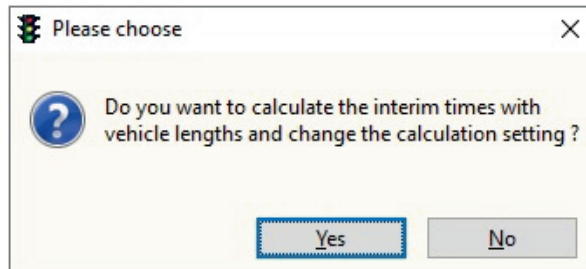

Note:

According to RiLSA, vehicle lengths must be included in calculations of interim times for crossing traffic flows. If you do not want this, confirm with **No**.

Step 2: Open General data

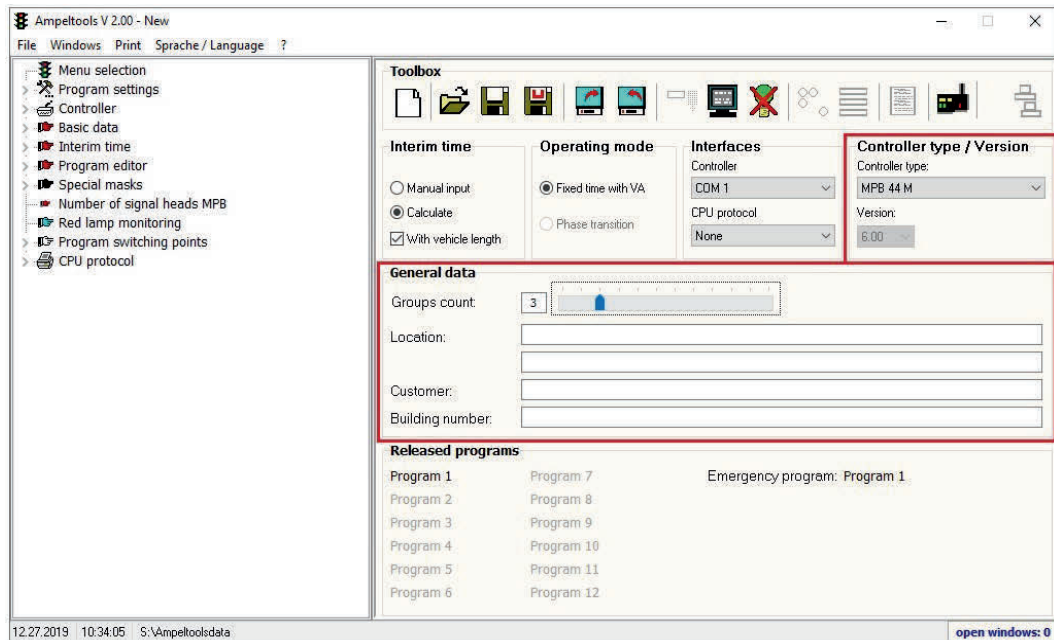

Fill in the details for the specific construction site in the input boxes.

The 'General data' dialog box is shown with the following input fields:

- Intersection time plan:**
 - Intersection time plan no.: 20191227-0001
 - Created by: Max Mustermann
 - 1st modification: [Empty]
 - 2nd modification: [Empty]
 - 3rd modification: [Empty]
 - Date: 2019-12-27
- Road work info:**
 - Road work project: [Empty]
 - Regulatory authority: [Empty]
 - Responsible official: [Empty]

Buttons at the bottom: Delete, Cancel, OK.

See 6.1.2 for a detailed description.

Step 3: Open Signal group master data

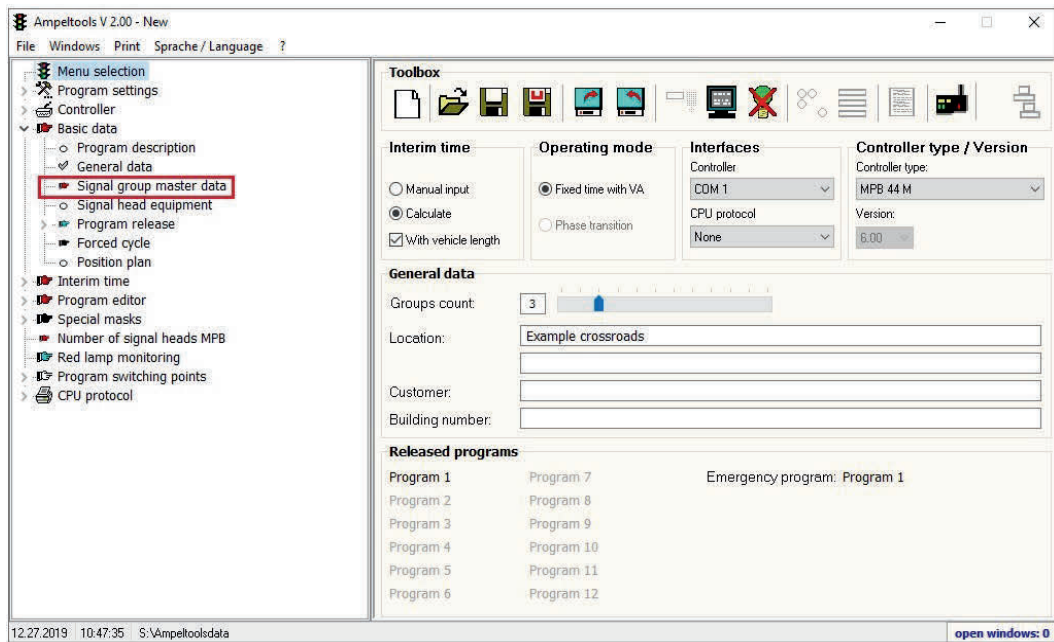

Enter the signal group name, red-yellow, yellow, minimum release times and calculation parameters for every signal group. The details should be entered according to the RiLSA or as required by the responsible authority. Tick **Flashing** for those groups that should switch to a yellow flashing light in the event of a fault or when selected.

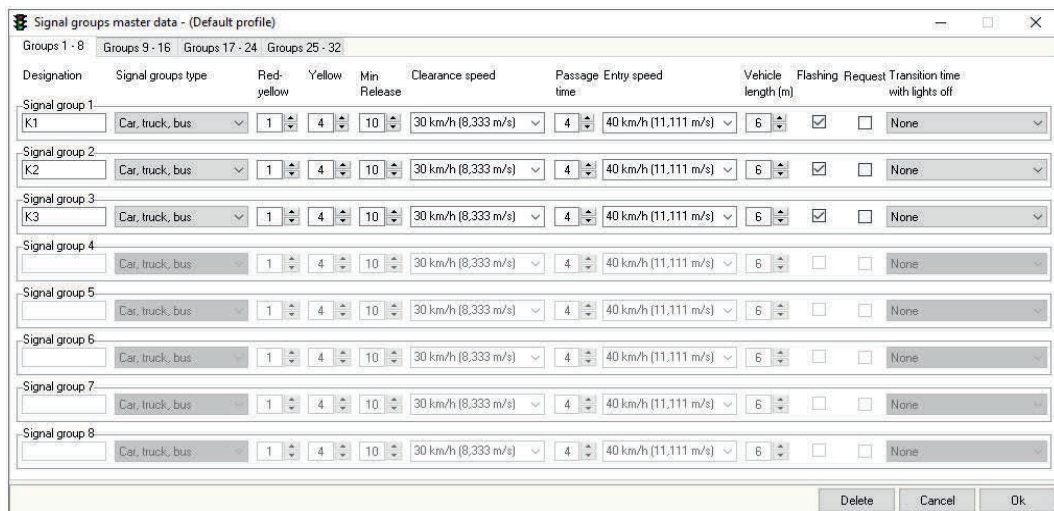

See 6.1.3 for a detailed description.

Step 4: Open Signal head equipment

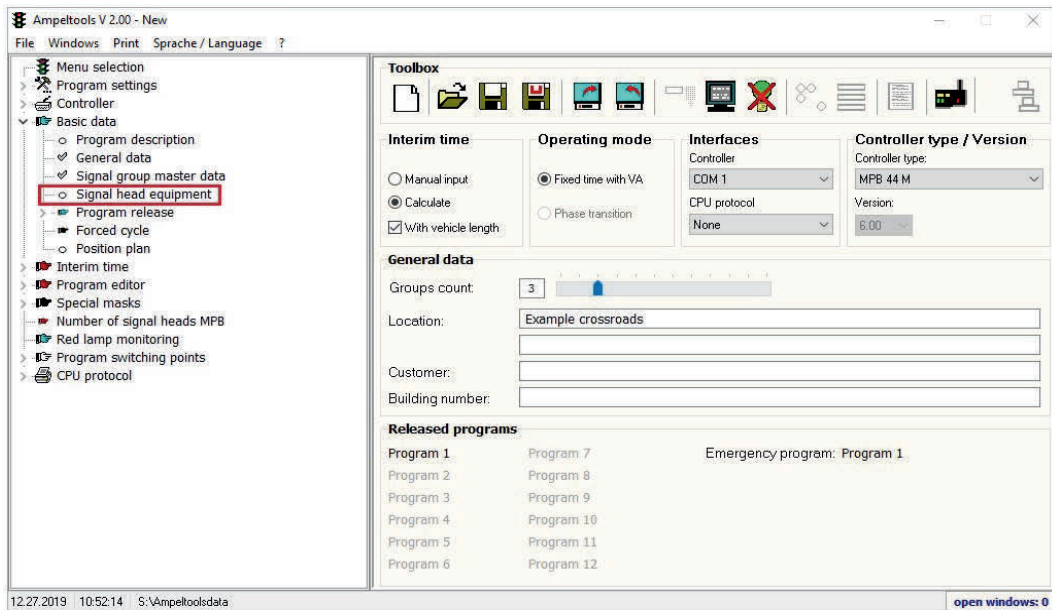

Select the respective equipment for every signal group.

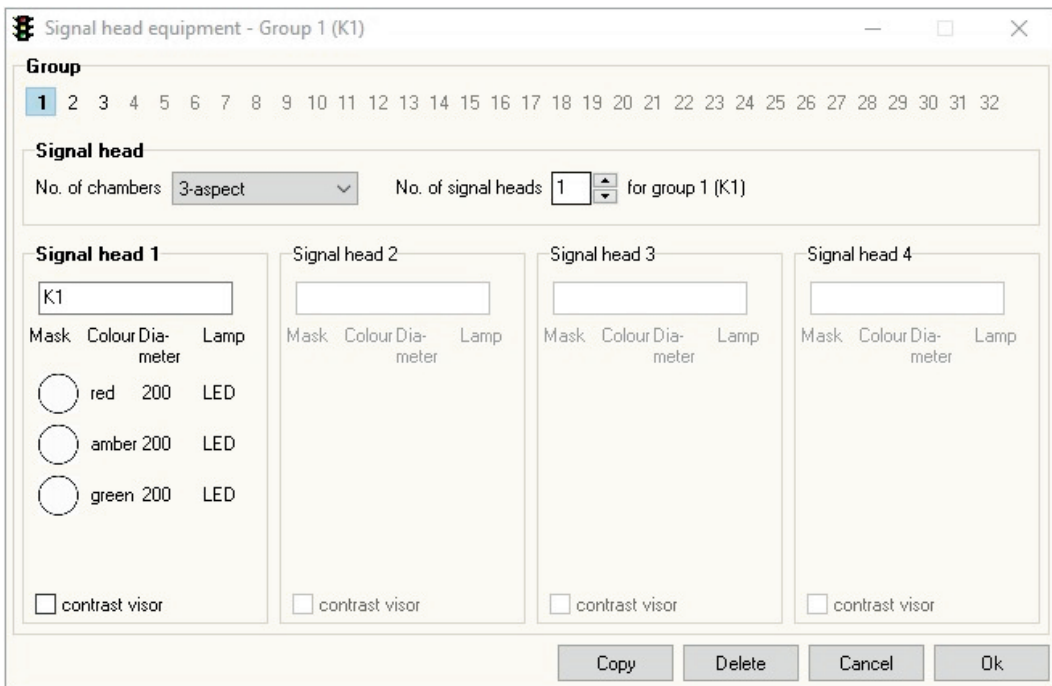

See 6.1.4 for a detailed description.

Step 5: Open Interlocking matrix

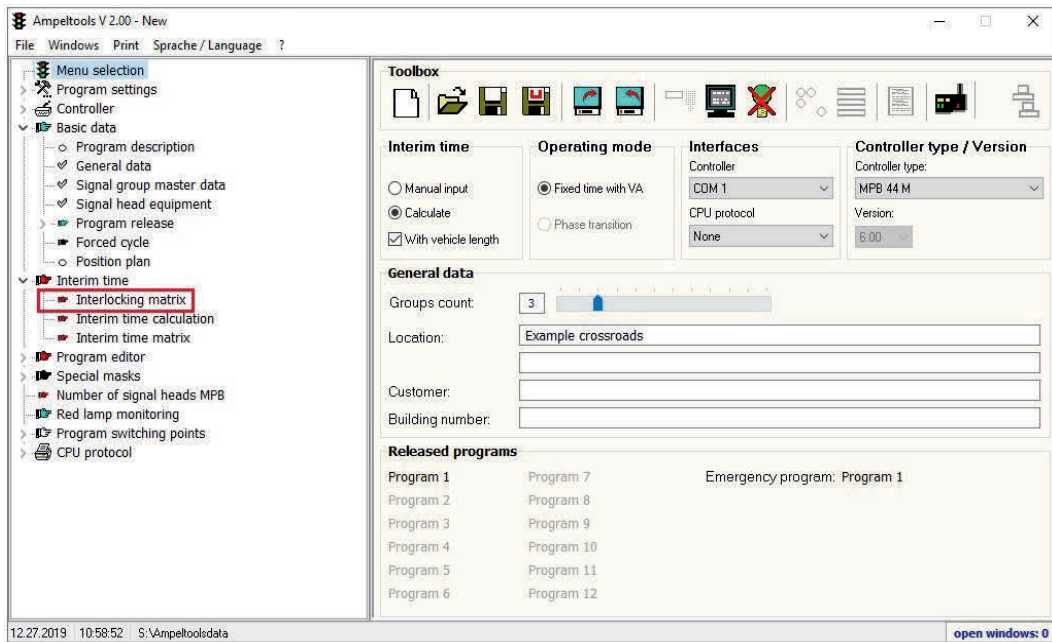

Do a double click with the left mouse button on those signal groups that are hostile to each other. The interim times are then calculated in each case.

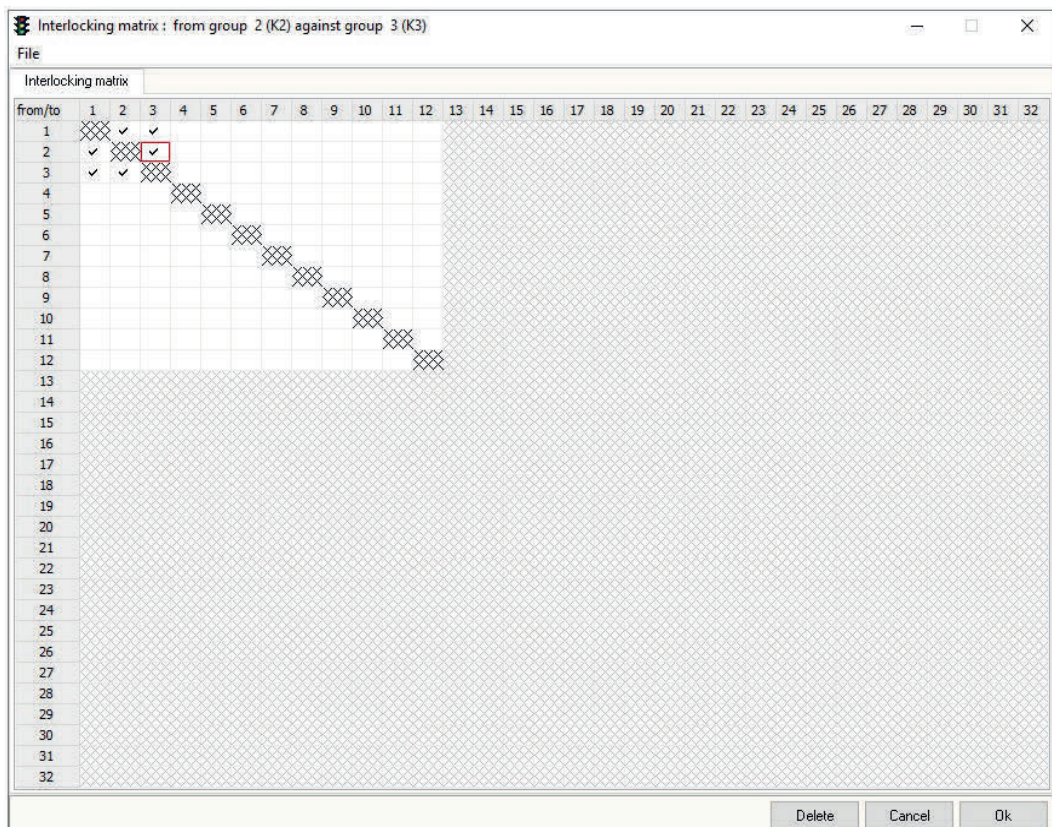

See 6.2.1 for a detailed description.

If data in this mask have been changed, a query appears when you close the mask whether the calculation mask should be opened. Please confirm with **OK**.

Step 6:

If **Interim time calculation** has not opened automatically, open it now manually.

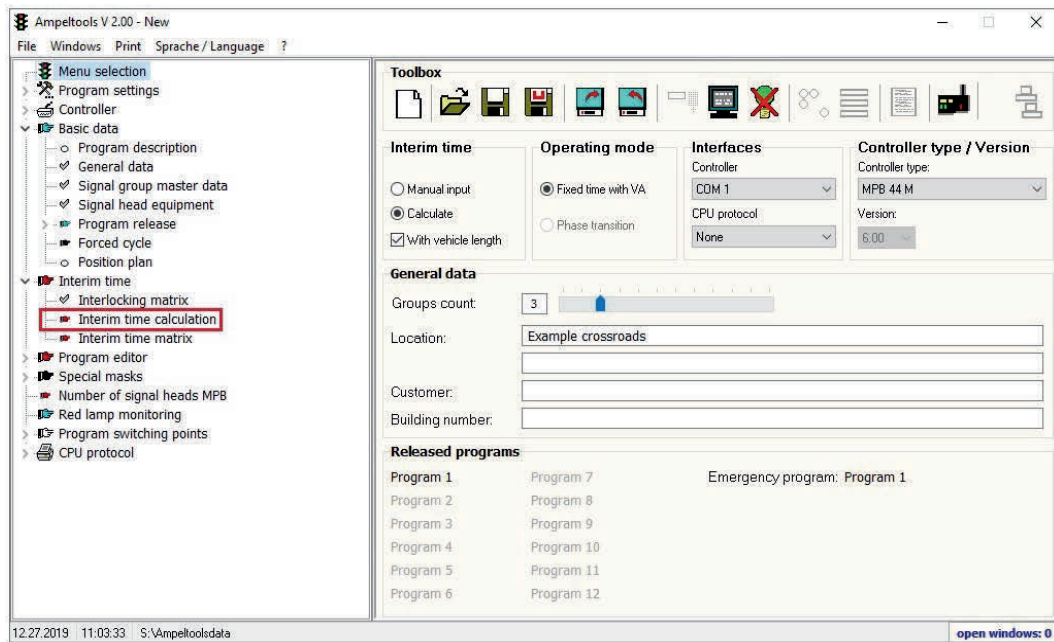

Enter the necessary data for interim time calculation for each clearance.

The calculation parameters are preset from the signal group master data, but can be adapted for every clearance. In certain circumstances, cyclists have to be taken into consideration so that other clearance speeds have to be chosen.

It may be necessary to consult the responsible authority here.

Interim time calculation according to RiLSA

Signal device designation				Clearance time (tr)				Entry time			Tü	Interim time			
No.	End Green	Lane ID (C)	Start Green	Lane ID (E)	Crossing distance in meters	Vehicle length in meters	Clearance distance in meters	Clearance speed	Time in sec.	Entry distance in meters	Entry speed	Time in sec.	Crossing time in secs.	Tz calculated in secs.	Tz selected in secs.
1	K1		K2		35,00	6	41,00	30 km/h	-4,920	0,00	40 km/h	0,000	4	8,920	9
2	K1		K3		86,25	6	92,25	30 km/h	11,070	0,00	40 km/h	0,000	4	15,070	16
3	K2		K1		32,50	6	38,50	30 km/h	-4,620	0,00	40 km/h	0,000	4	8,620	9
4	K2		K3		30,25	6	36,25	30 km/h	-4,350	0,00	40 km/h	0,000	4	8,350	9
5	K3		K1		88,75	6	94,75	30 km/h	11,370	0,00	40 km/h	0,000	4	15,370	16
6	K3		K2		41,25	6	47,25	30 km/h	-5,670	0,00	40 km/h	0,000	4	9,670	10

See 6.2.2 for a detailed description.

If closed with **OK**, the interim time matrix is produced automatically.

Step 7: Open Interim time matrix

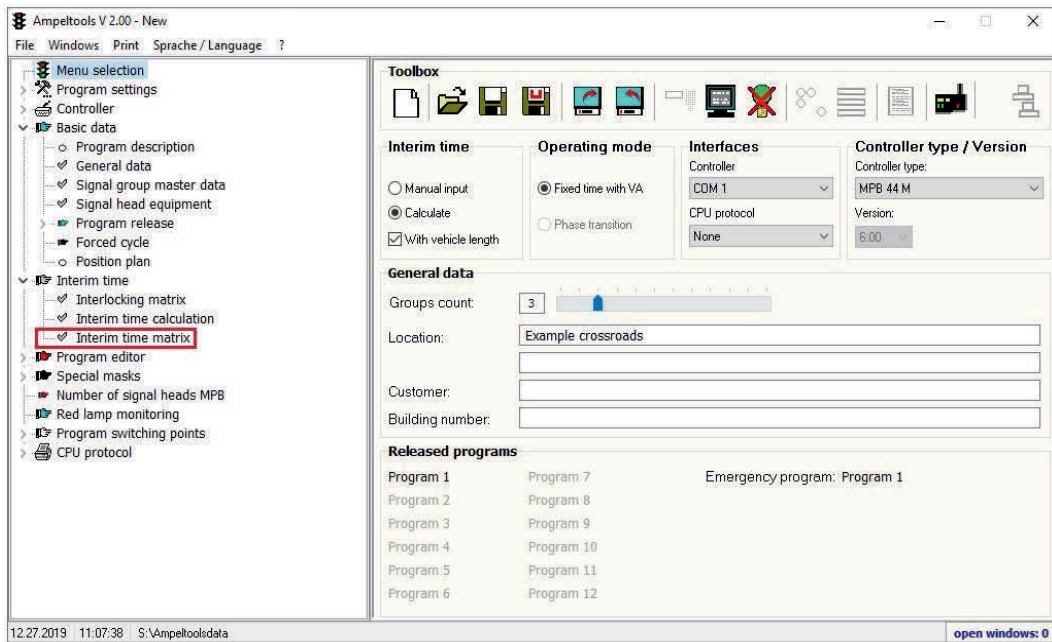

Here you can check the values taken from the interim time calculation. It is not possible to change them here.

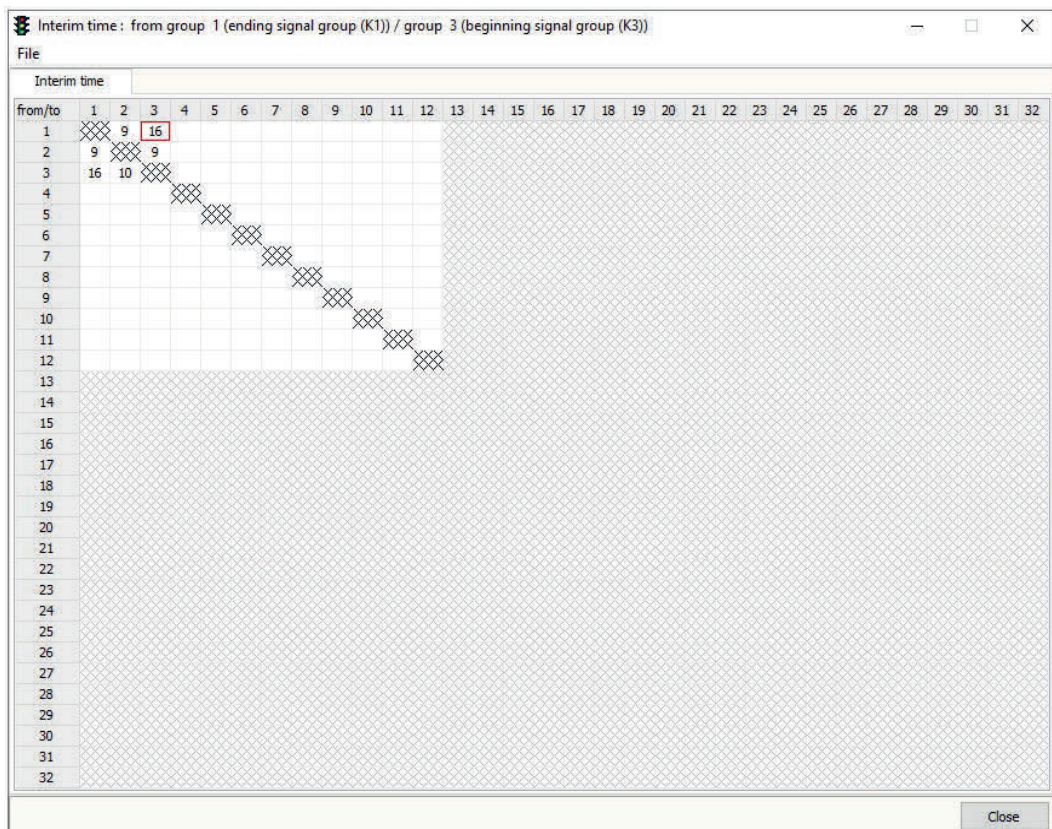

See 6.2.2 for a detailed description.

Step 8: Open Intersection time plan editor

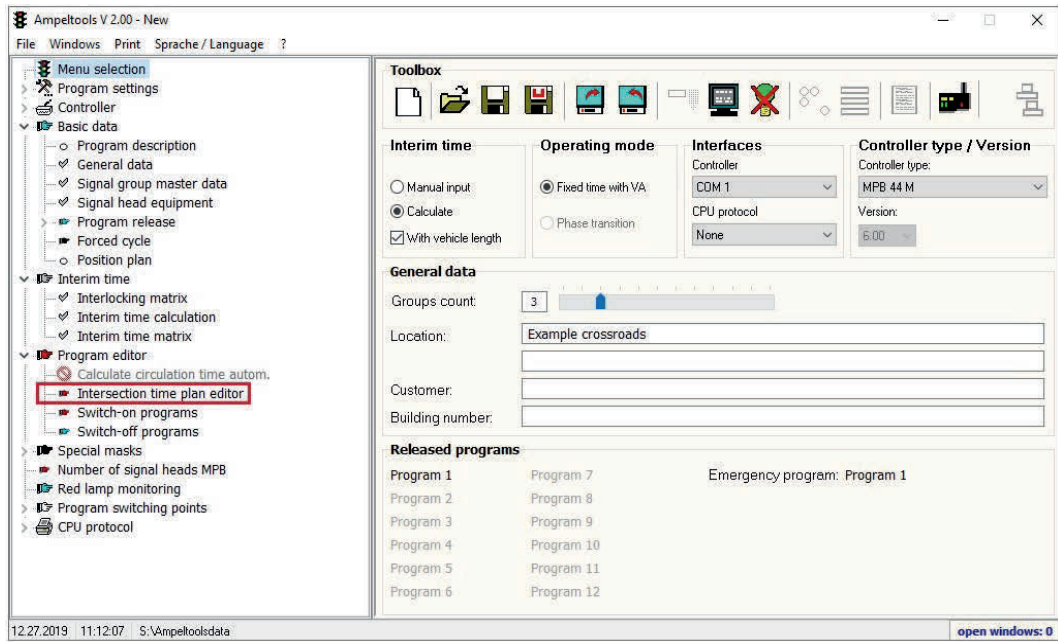

Step 9: Intersection time plan editor

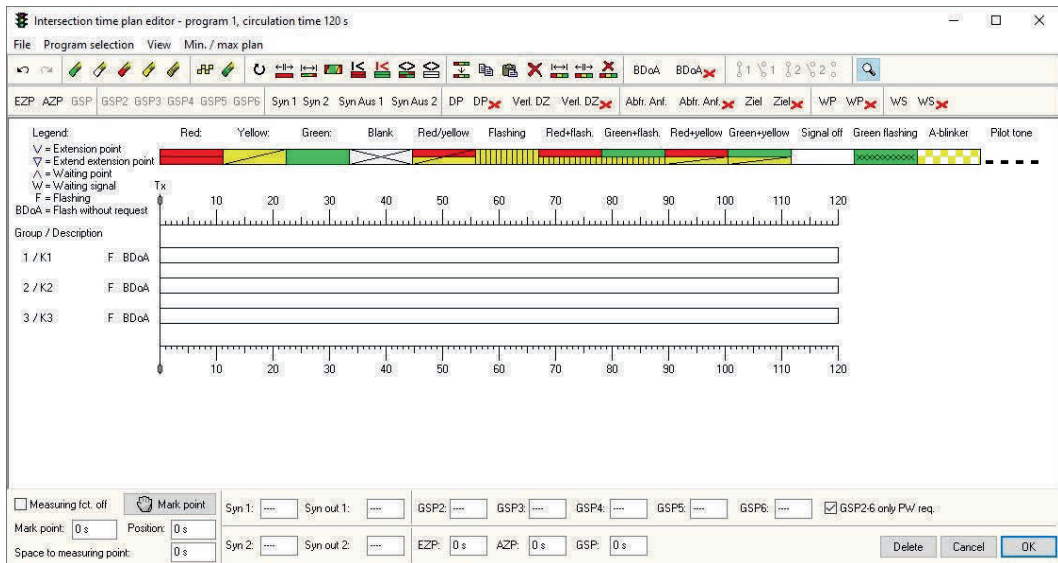

Create the minimum intersection time plan manually (see 6.3.4.1) or using the automatic function (see 6.3.5.7).

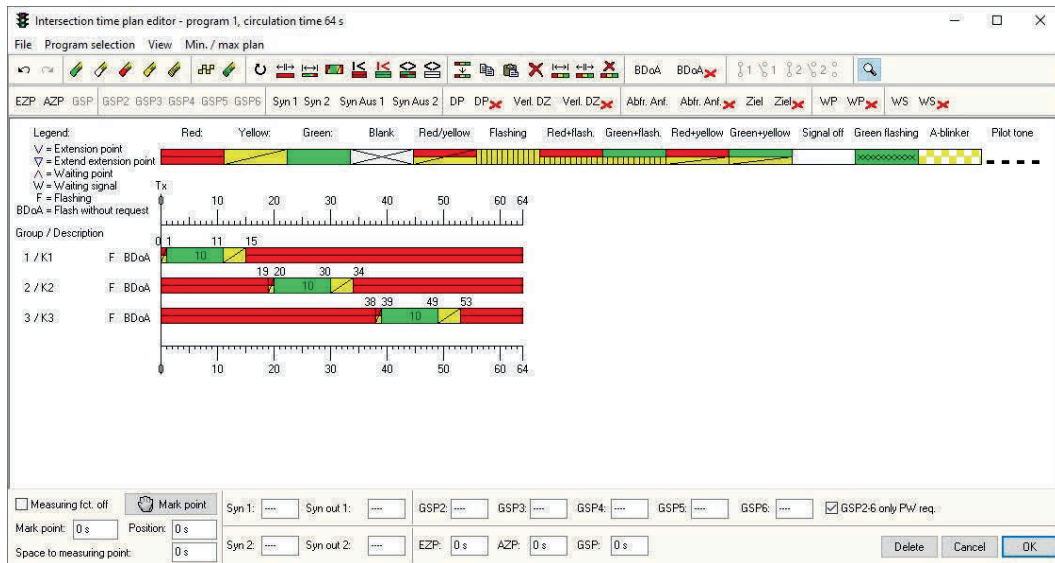

See 6.3.3 / 6.3.4 for a detailed description.

Step 10:
 Add vehicle actuation
 Click on **DP**

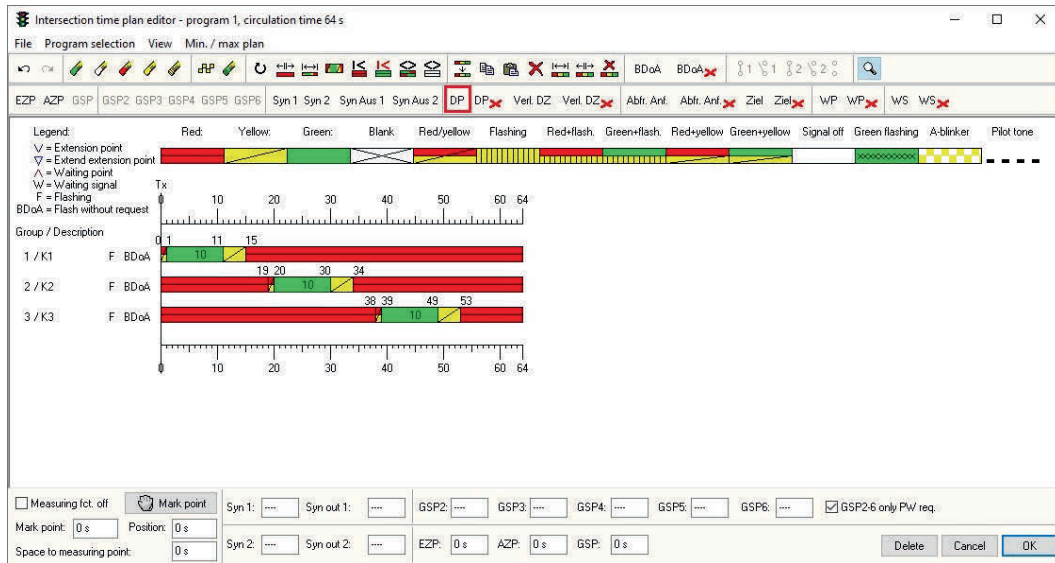

With the left mouse button, position the extension point one second before the end of the green phase in the first signal group.

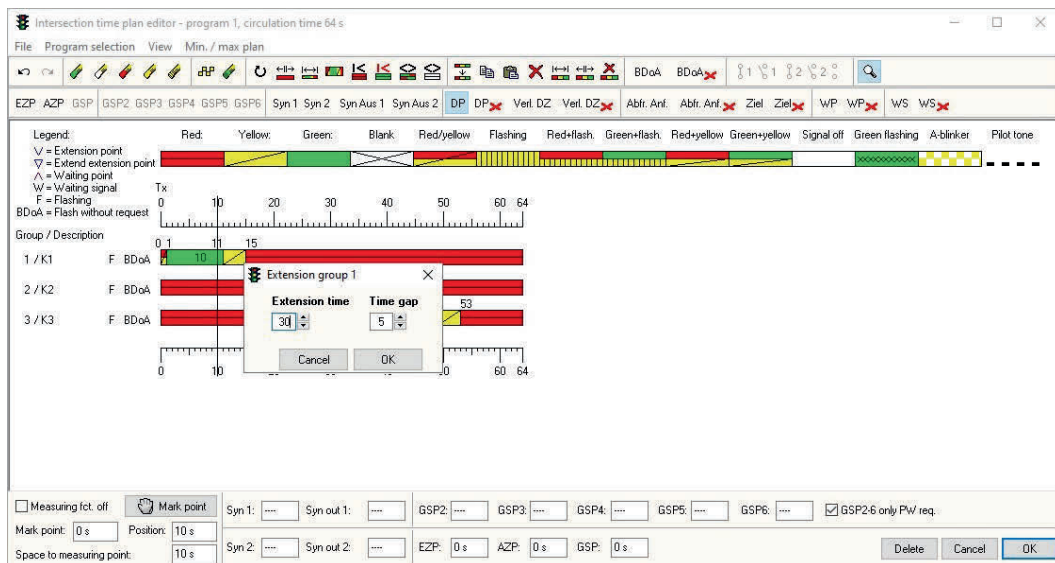

Enter the values for extension Syn time and time gap in the corresponding window.
 Confirm with **OK**.
 Repeat for all signal groups that should work with green phase extension.

See 6.3.6 for a detailed description.

Step 11:
Insert ON time
Click on EZP

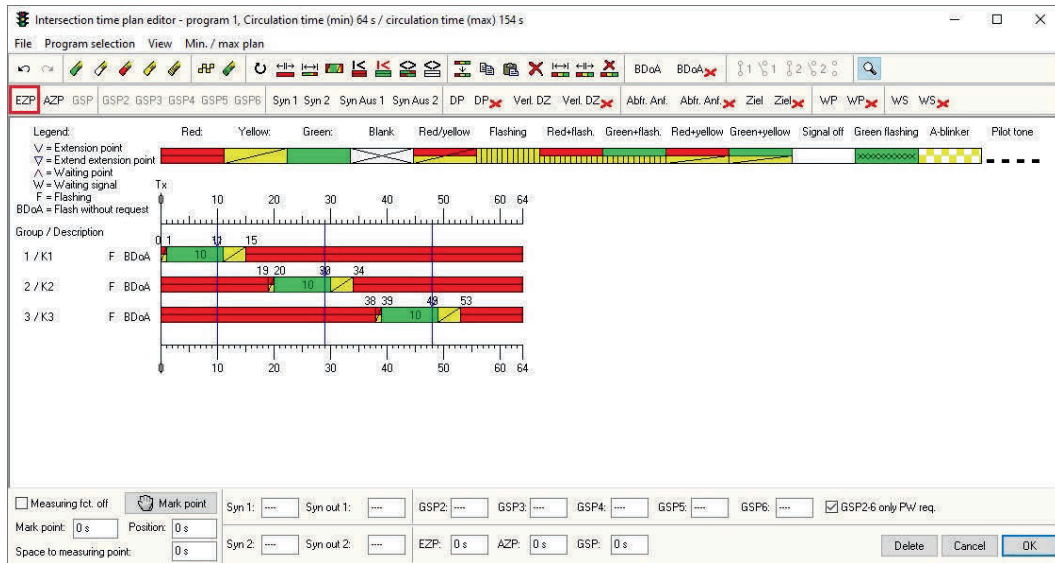

Mark the required ON time by clicking the mouse in the required second of the cycle. As a rule, this is always in a continuous red point in the intersection time plan, immediately before red-yellow of a signal group. In the example, this is the second 0. The EZP adjusted in this way is then shown below in the intersection time plan editor.

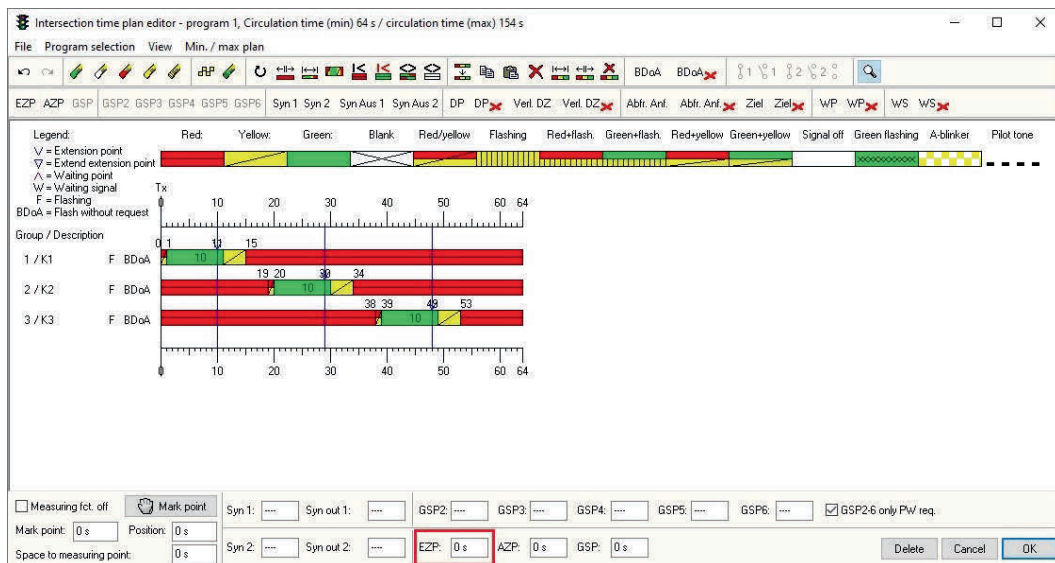

See 6.3.4.8 for a detailed description

Step 12:
Insert OFF time
Click on AZP

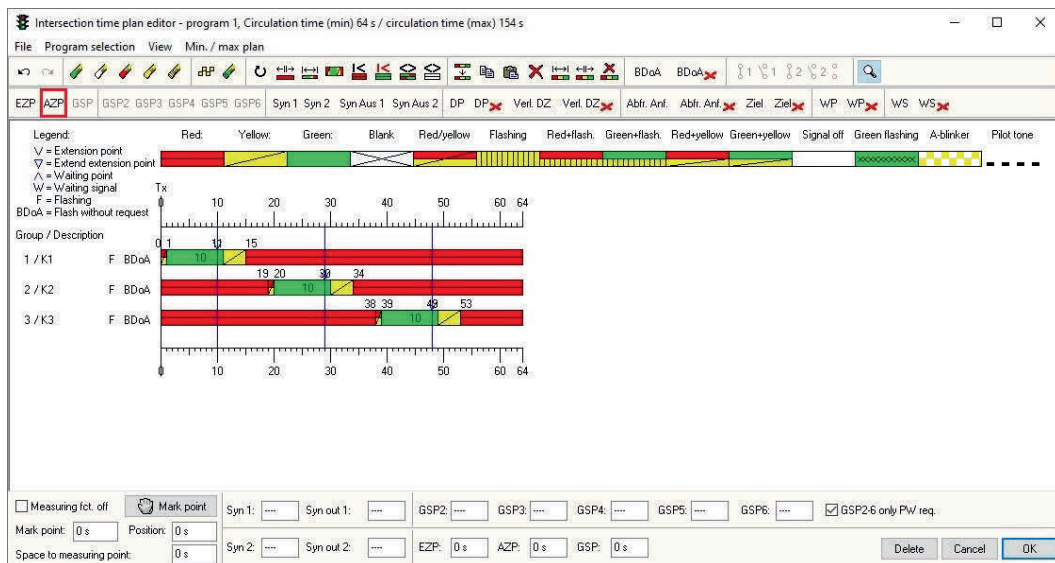

Mark the required OFF time by clicking the mouse in the required second of the cycle. As a rule, this is always in a continuous red point in the intersection time plan. In the example, this is the second 15. The AZP adjusted in this way is then shown below in the intersection time plan editor.

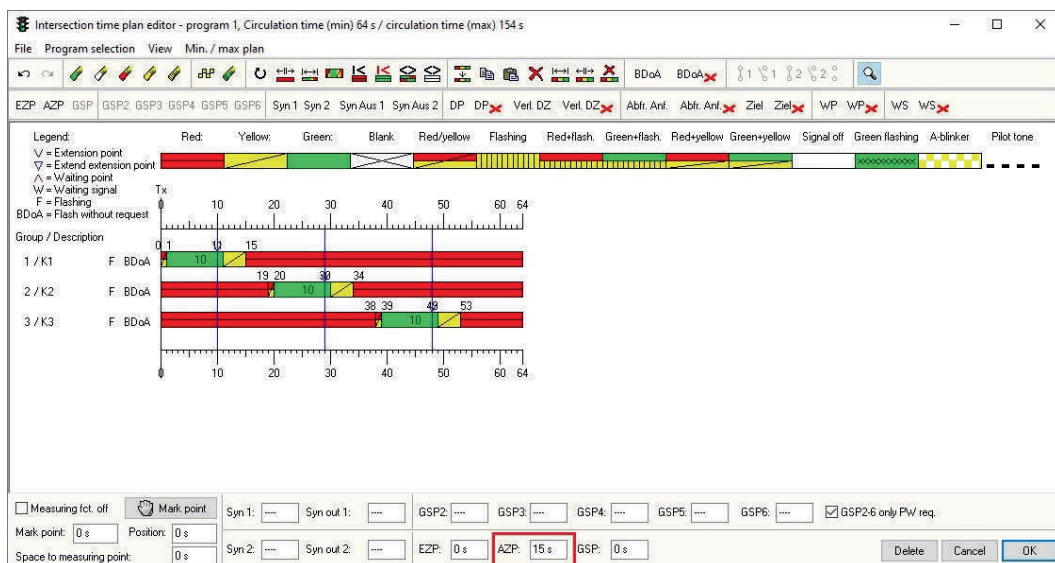

See 6.3.4.9 for a detailed description

For controller type MPB4xxx, a message about checking signal safeguarding appears on closing the mask.

Here you can check the preset red lamp monitoring function, adjust if necessary and close with **OK**.

Prg./Grp.	1	2	3	4	5	6	7	8	9	10	11	12	13	14	15	16	17	18	19	20	21	22	23	24
P1	✓	✓	✓																					
P2																								
P3																								
P4																								
P5																								
P6																								

See 6.6.4 for a detailed description.

Note:

If you are using a controller of type series EPB 12, EPB 24 or EPB 48, the signal safeguarding mask does not open automatically. It has to be selected manually.
See step 16.

Step 13: Open Switch-on programs

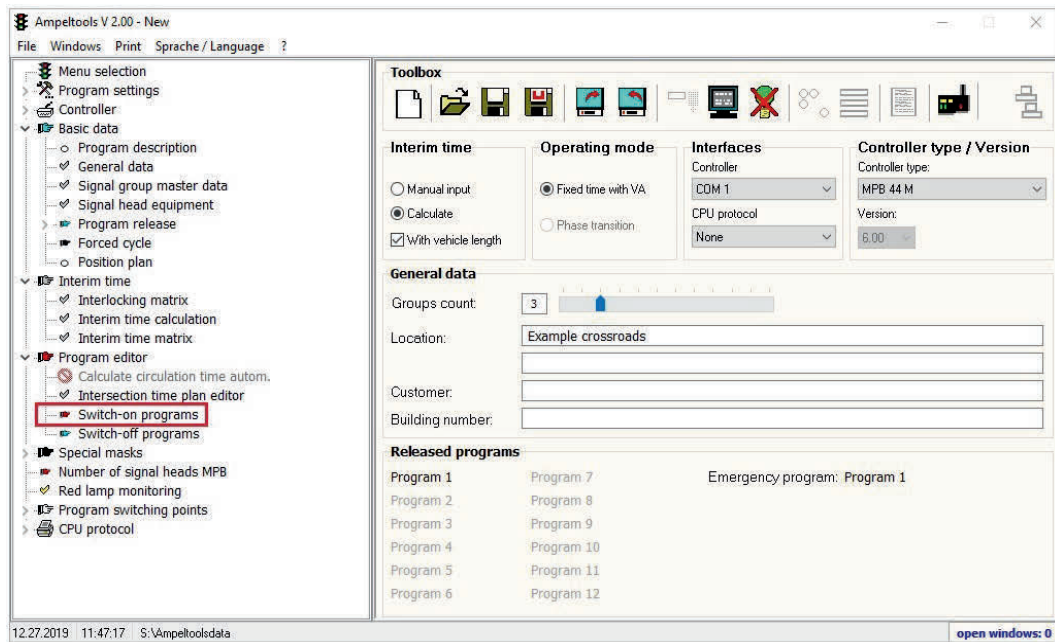

Enter **5** as the step time for step 1. For step 2, enter the result obtained by deducting the five seconds for the first step from the **Longest interim time in matrix**. (Vice versa, add the values from step 1 and 2 to obtain the value stated as **Longest interim time in matrix**.) Nothing is entered for step 3.

According to RiLSA 2015 recommendation, these defaults correspond to a switch-on program for using traffic signal systems going over and beyond bottleneck control. The total time of the switch-on program should correspond to the longest value in the interim time matrix. However, if the responsible authority specifies another switch-on program, please adjust the switch-on program described above and the ON point according to the specifications from the authority.

Switch-on programs/ON points may differ, depending on whether the traffic light system is intended for road works or as a substitute (e.g. for stationary traffic lights / on a diversion).

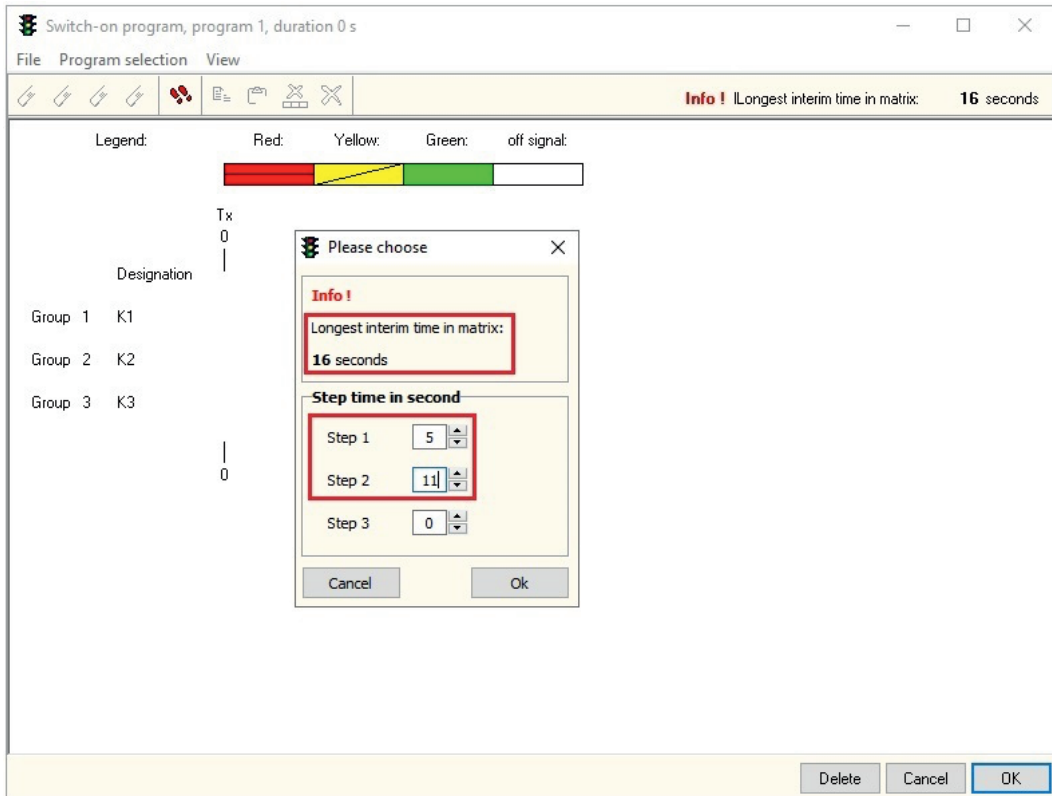

Confirm with **OK** to open the switch-on program editor. This has two areas according to the step time, separated by a dividing line.

The first 15 seconds from the ON time of the signal program are shown in the right area.

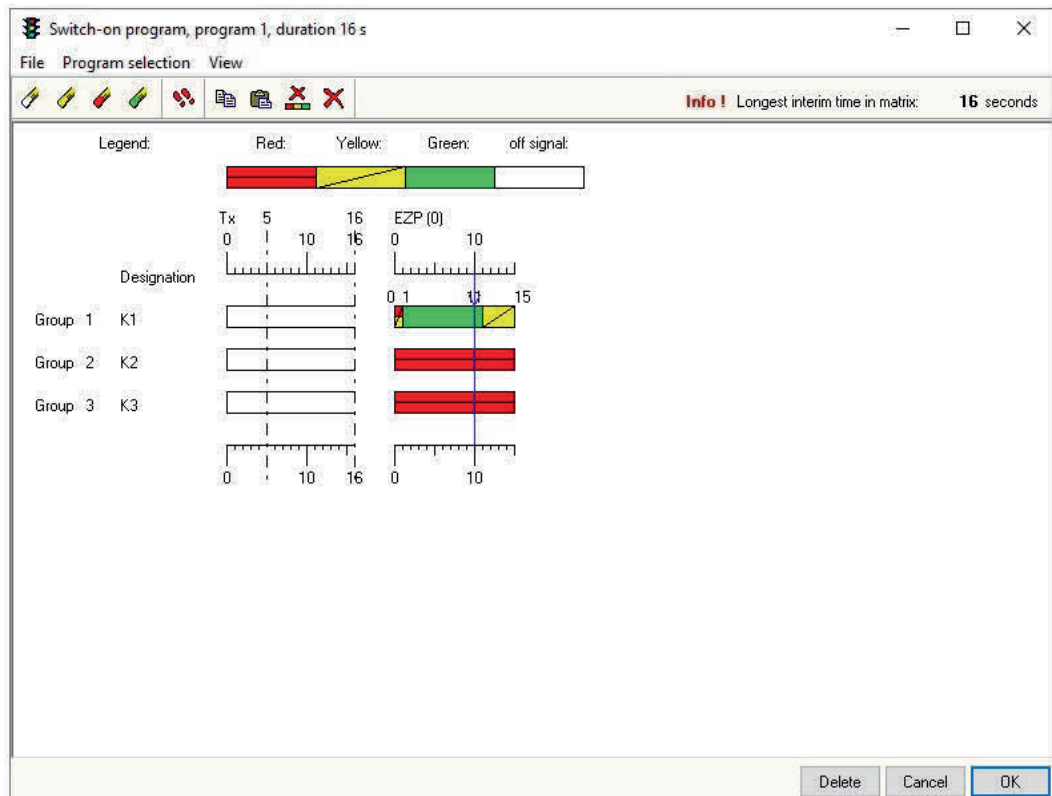

Select the yellow paintbrush with the left mouse button, then click in the first step marking for both signal groups one after the other. They change colour to yellow. Then select the red paintbrush and click in the second step marking for both signal groups one after the other. They change colour to red.

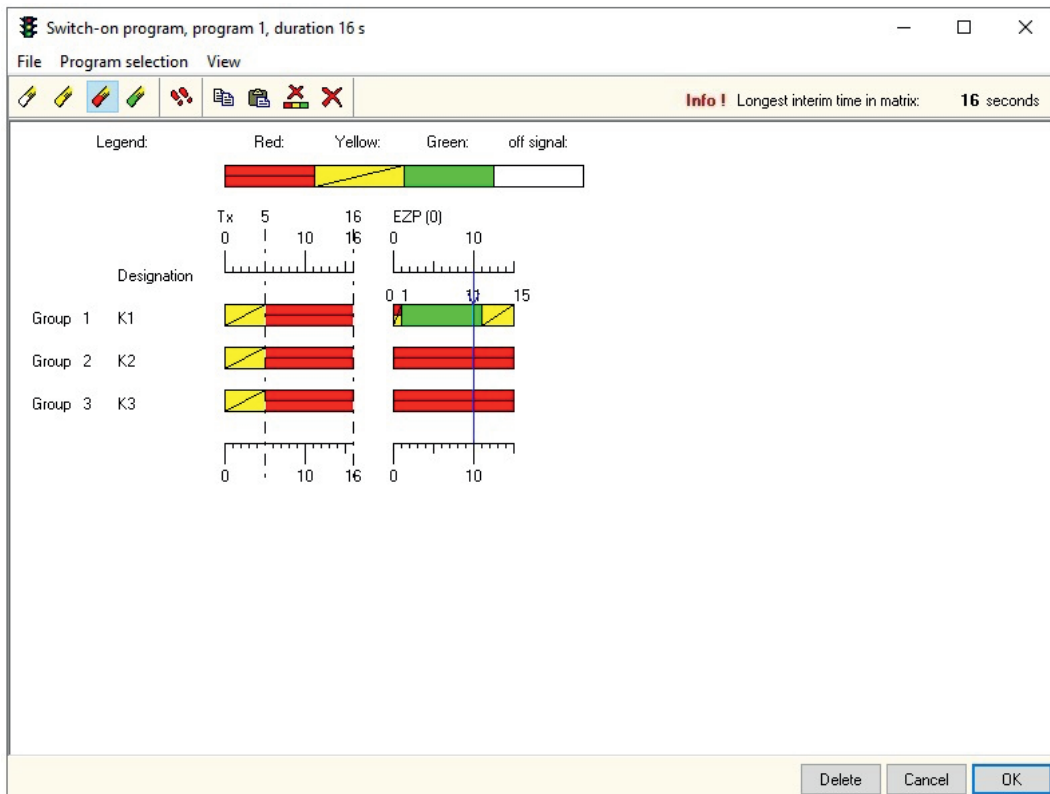

After creating the switch-on program, this (left area) should move on seamlessly to the ON point of the signal program (right area)

See 6.3.8 / 6.3.8.4 for a detailed description.

If you are using a controller of type series EPB 12, EPB 24 or EPB 48, the switch-on program is created graphically (like the intersection time plan editor).

See 6.3.8.3 for a detailed description

Step 14: Open Switch-off programs

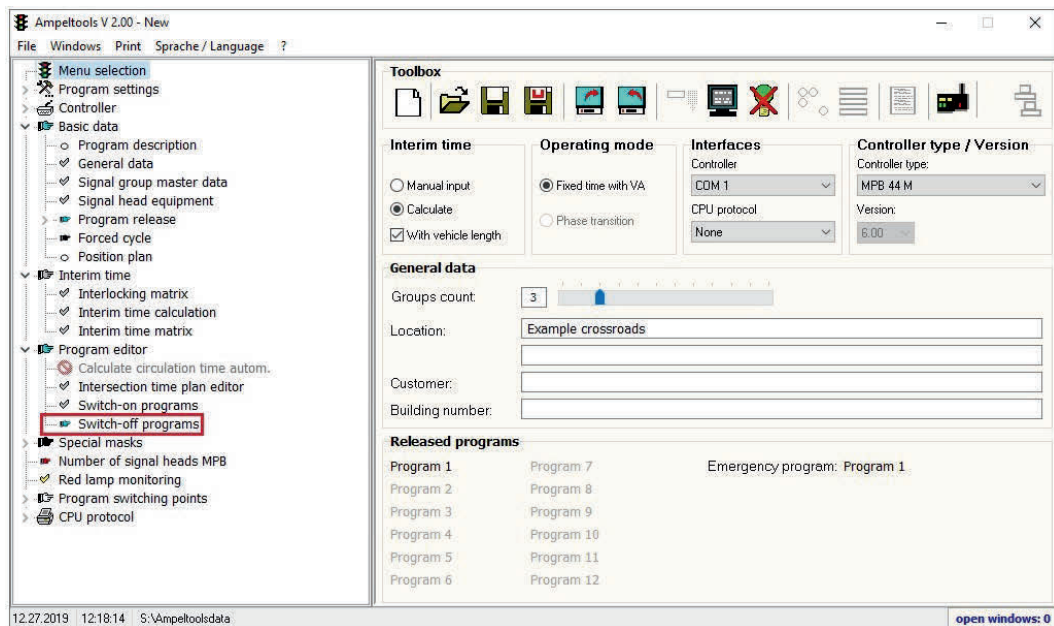

As step time, enter the highest value from the interim time matrix shown to you as **Longest interim time in matrix**. Nothing is entered for the two other steps.
 RiLSA 2015 has no defined switch-off patterns for roadwork traffic light systems. There is only one example for possibly switching off with continuous red.
 It may be necessary to consult the responsible authority here, in which case the switch-off program and the OFF point may have to be adjusted

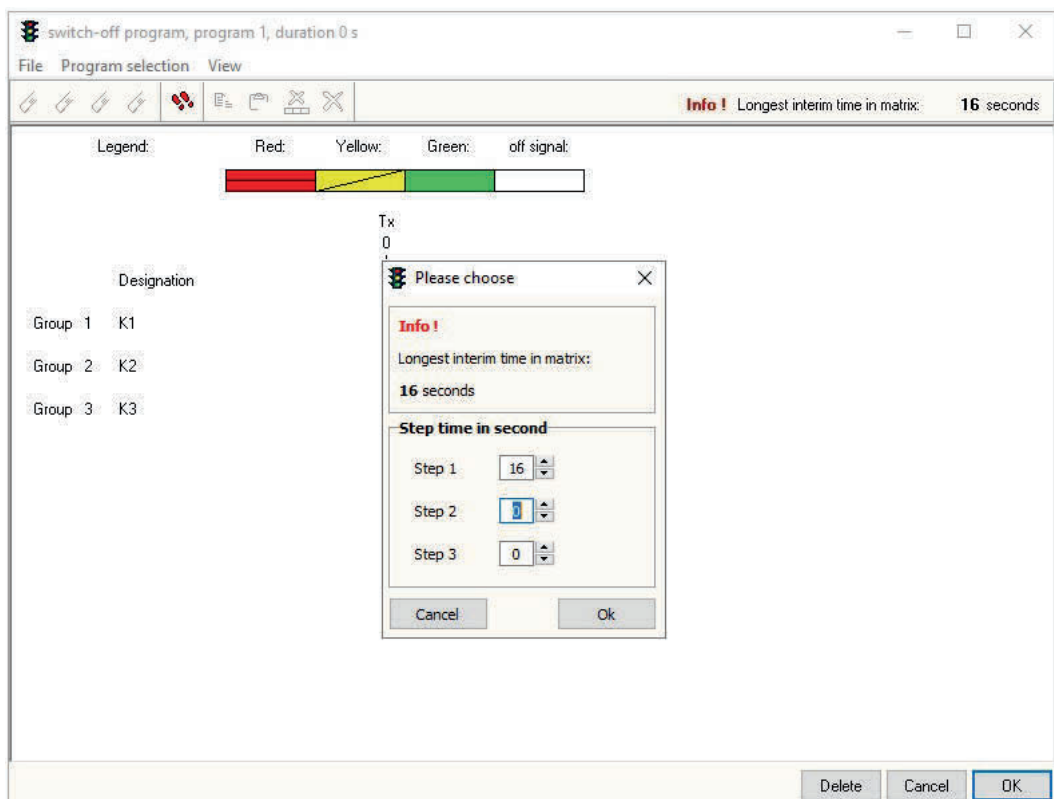

Confirm with **OK** to open the switch-off program editor.

The last 15 seconds from the OFF time of the signal program are shown in the left area.

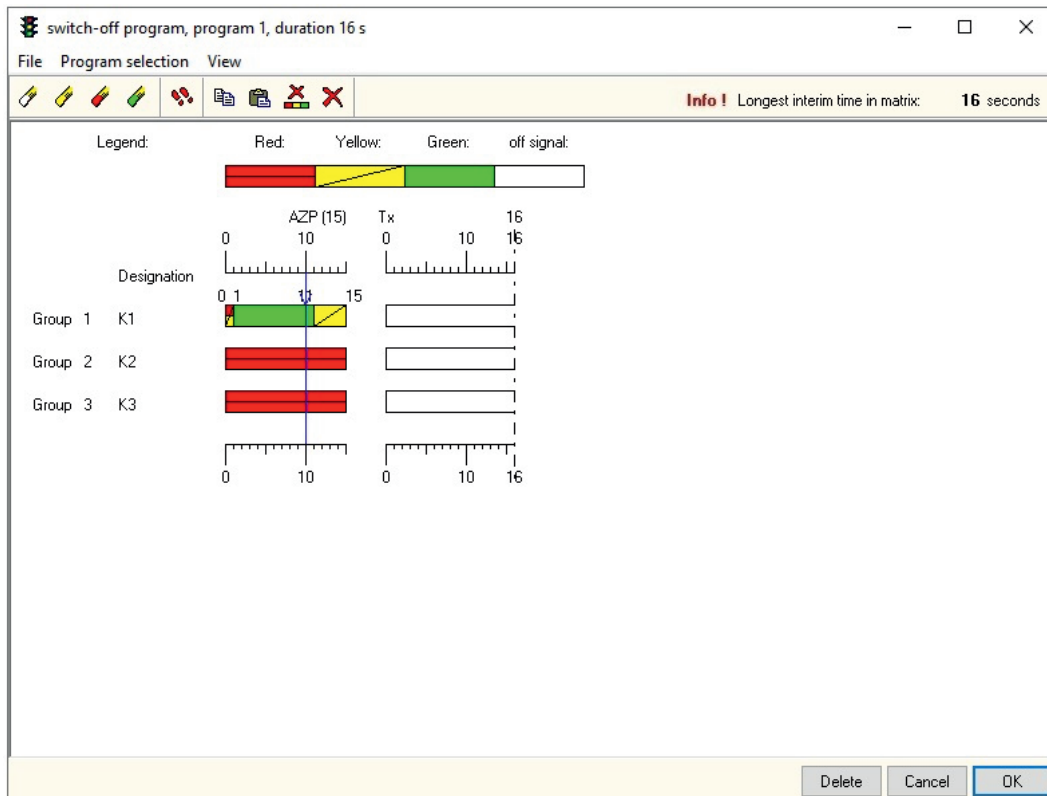

Select the red paintbrush with the left mouse button, then click in the step marking for both signal groups one after the other. They change colour to red.

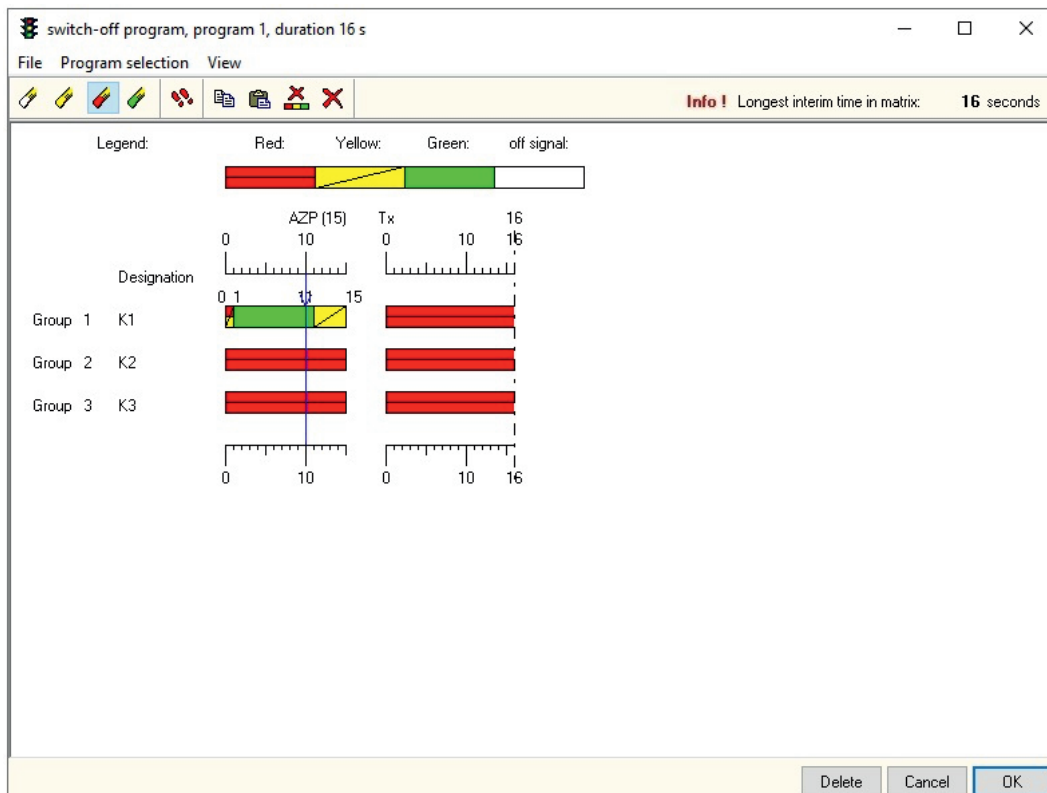

After creating the switch-off program (right area), this should move on seamlessly to the signal program (left area).
See 6.3.9 for a detailed description.

If you are using a controller of type series EPB 12, EPB 24 or EPB 48, the switch-off program is created graphically (like the intersection time plan editor).
See 6.3.9 for a detailed description.

Step 15:
Open Number of signal heads MPB

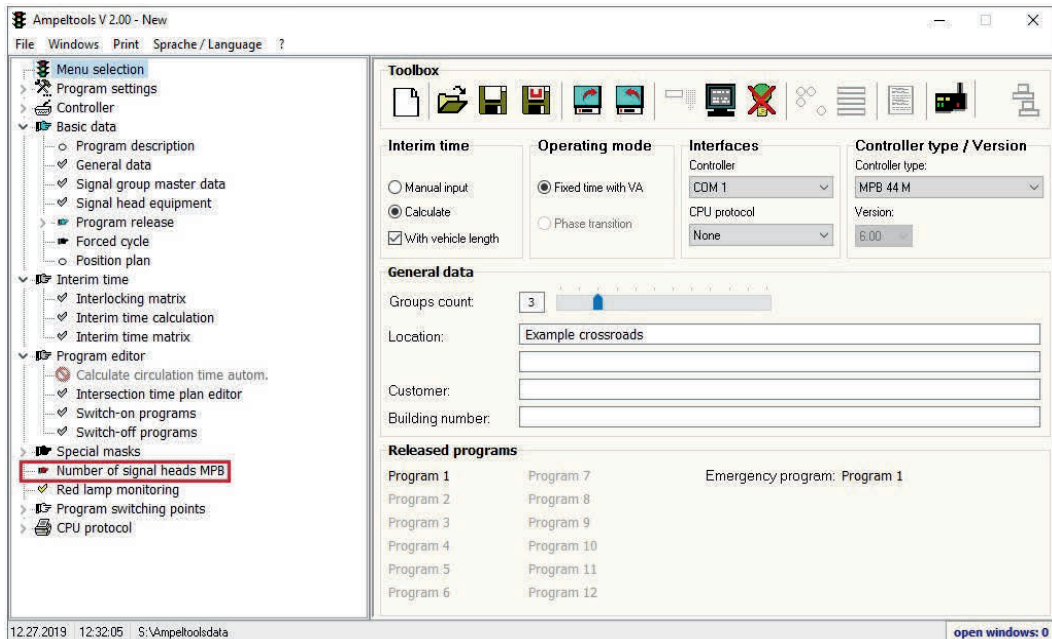

Here you can enter the number of signal heads with controller in each signal group.



See 6.5 for a detailed description.

Step 16:

Open Signal safeguarding

– only necessary for controller type EPB 12, EPB 24 or EPB 48, otherwise continue with step 17.

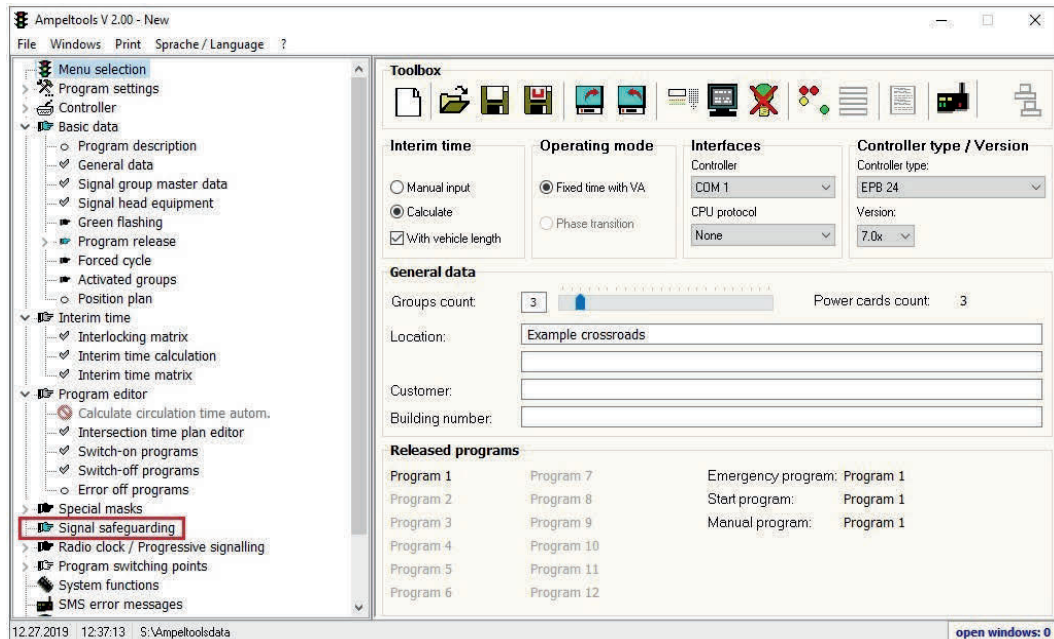

Here you can configure signal safeguarding for every signal group.

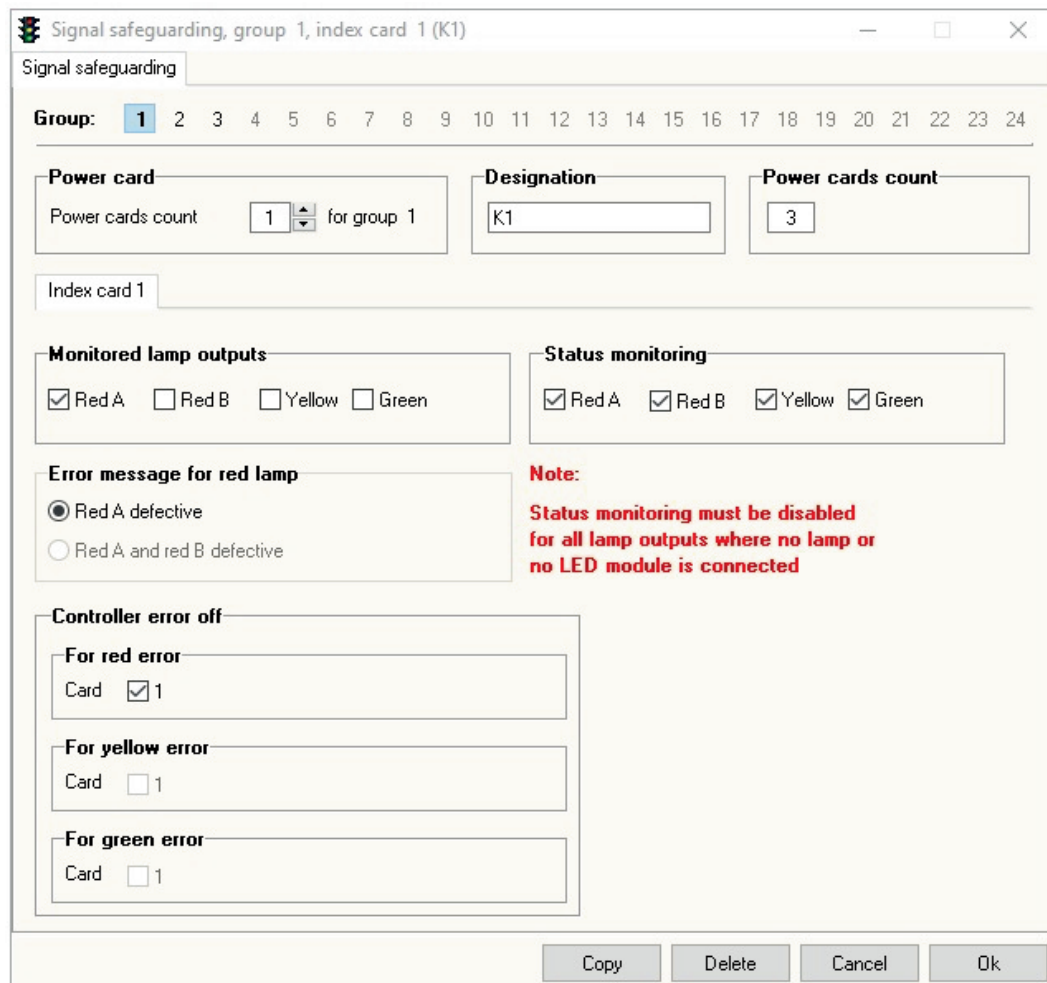

See 6.6.2 for a detailed description.

Step 17:

Save existing data

To save existing data, click on **Save data**.

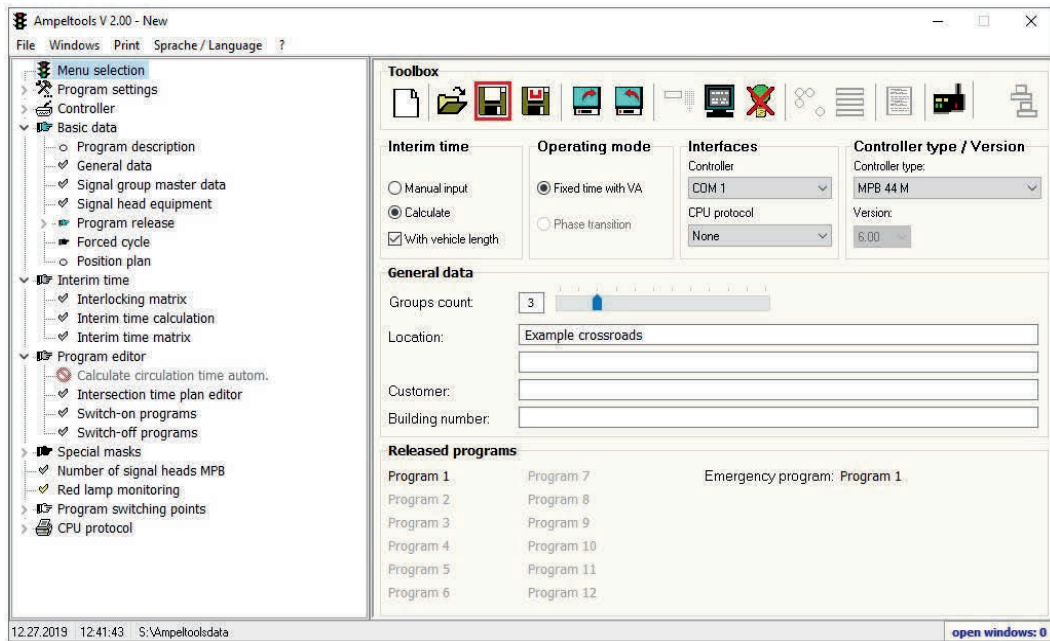

Please enter a file name for saving the program.

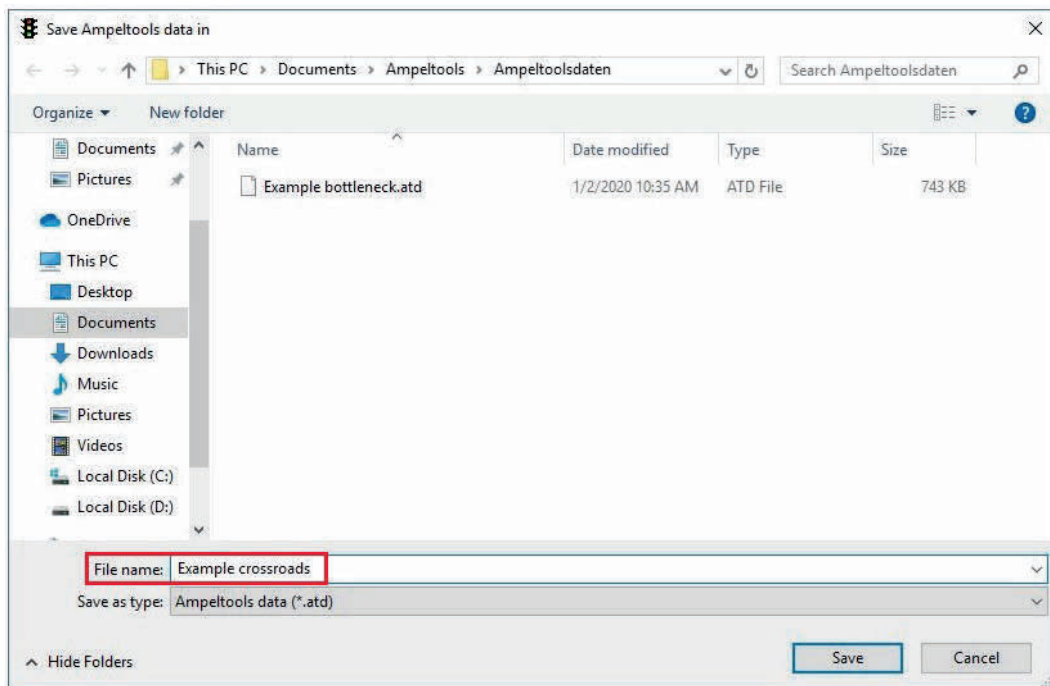

Confirm with **Save**.

The data will be saved accordingly with a corresponding progress bar.

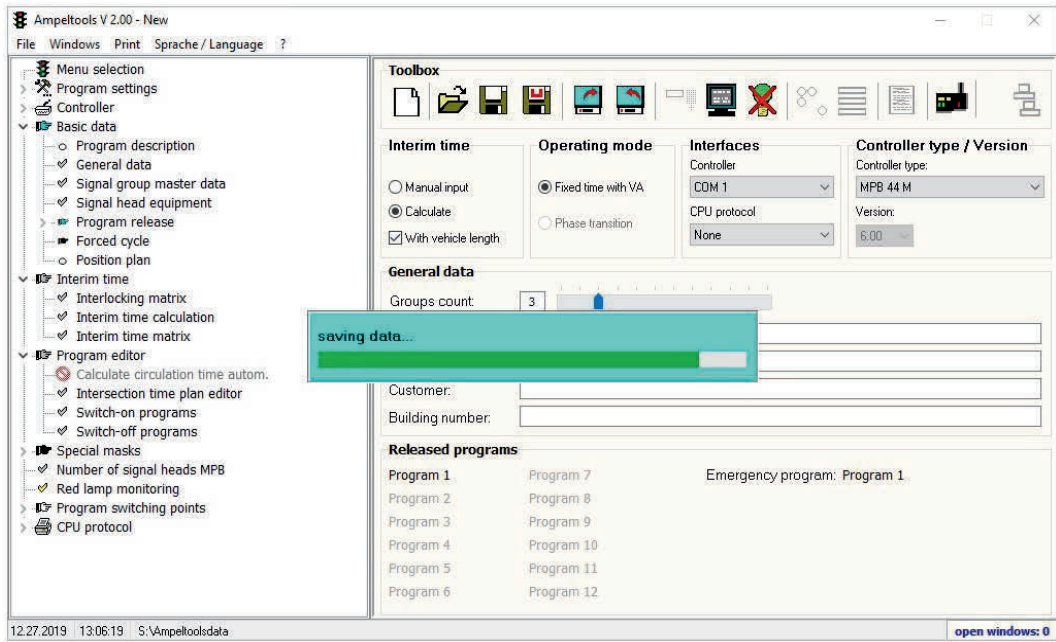

When the data have been saved, the file name appears in the main window.

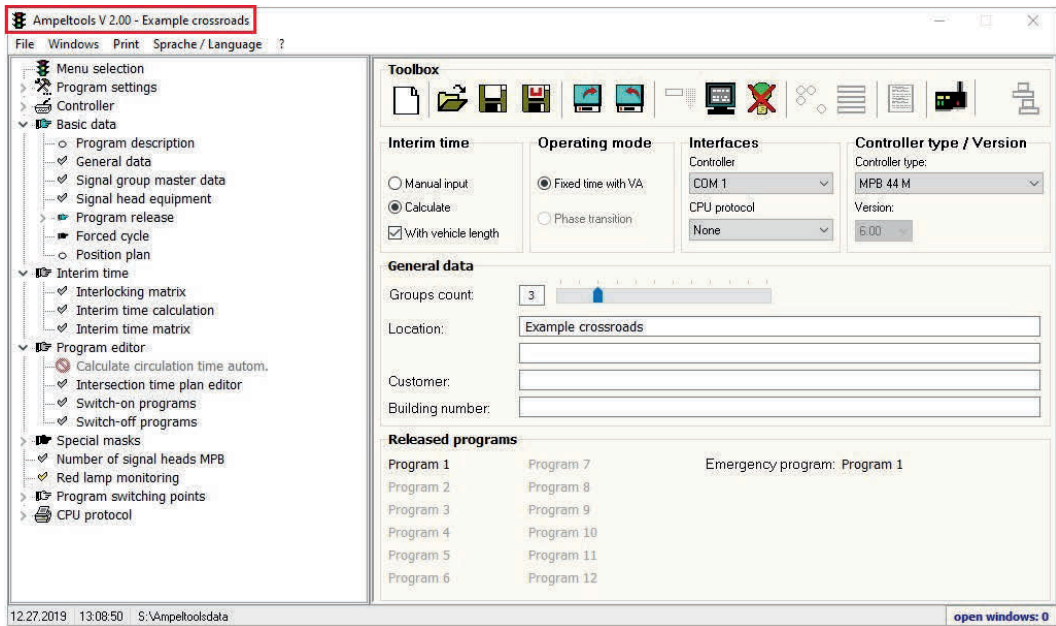

See 4.2.2 / 4.2.3 for a detailed description.

Step 18:

Print existing data

To print existing data, select the required function in the print menu or use **Print all**.

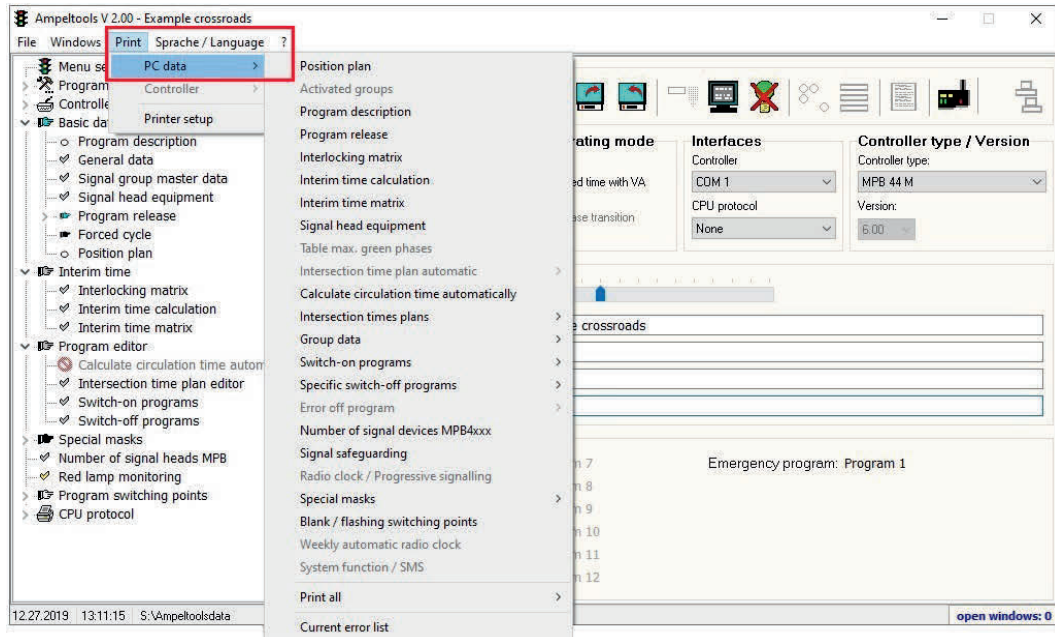

See 4.4.3 / 4.4.3.1.5 for a detailed description.

Step 19:

Data transfer to 12 groups interface

Select the corresponding serial interface for data transfer. If you use a USB serial converter, it should be plugged in before you start Ampeltools. Connect the USB serial converter with the corresponding PC lead and the 12 groups interface.

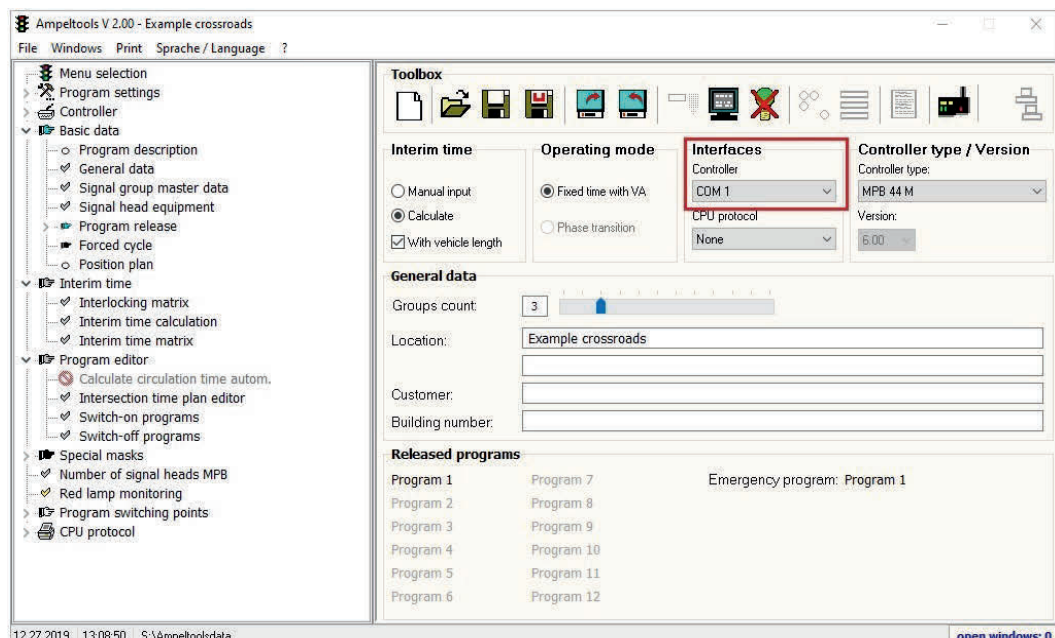

If no interface is selected, all data transfer functions are disabled.

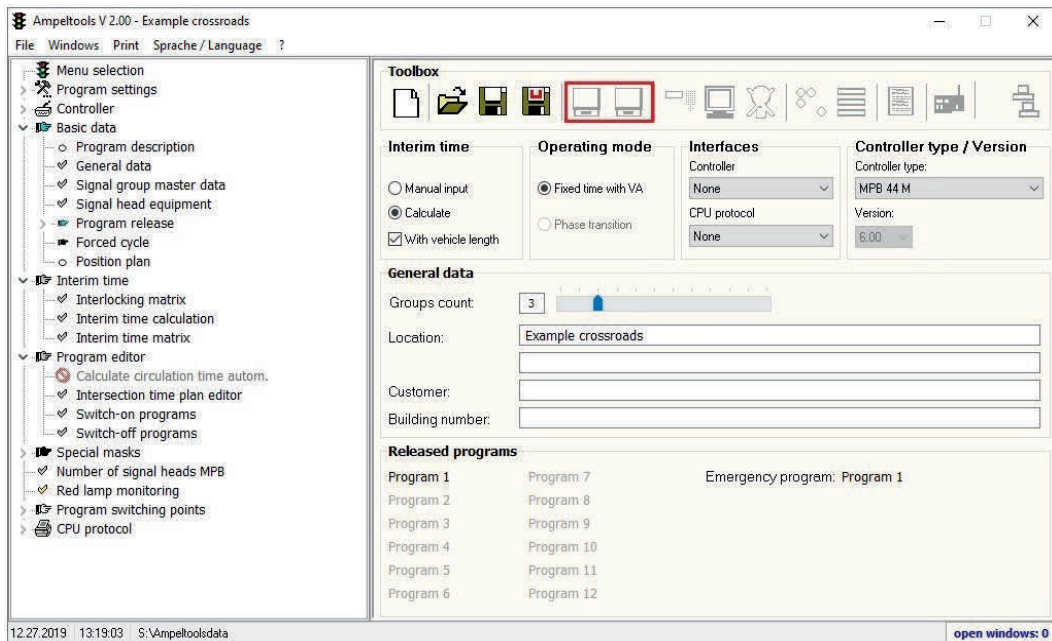

Select the corresponding setting for data reception at 12 groups interface

Press the corresponding button to start data transfer.

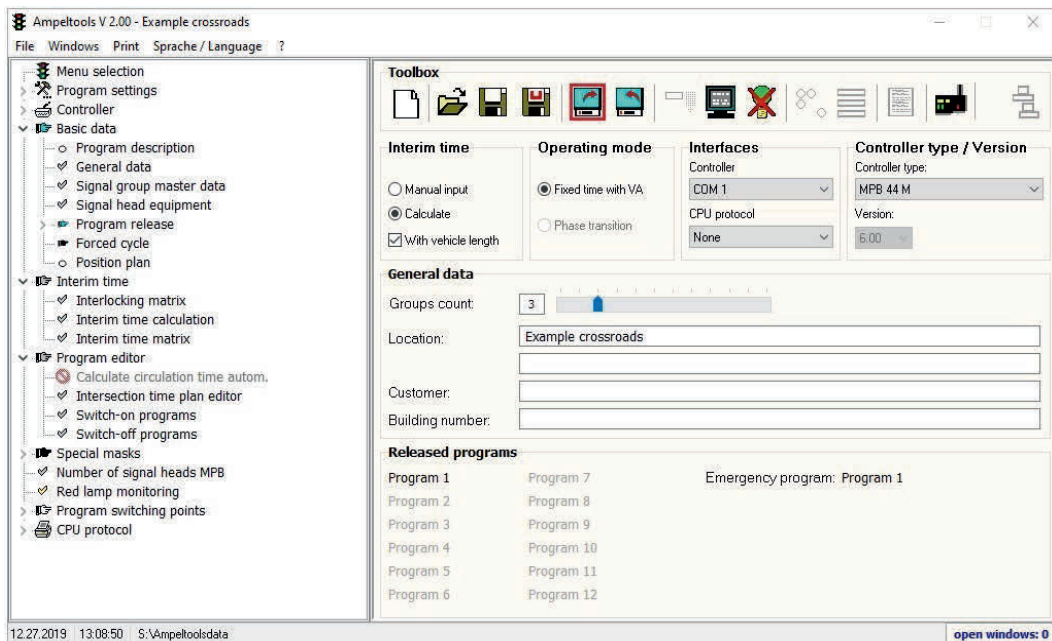

The data transfer window opens.

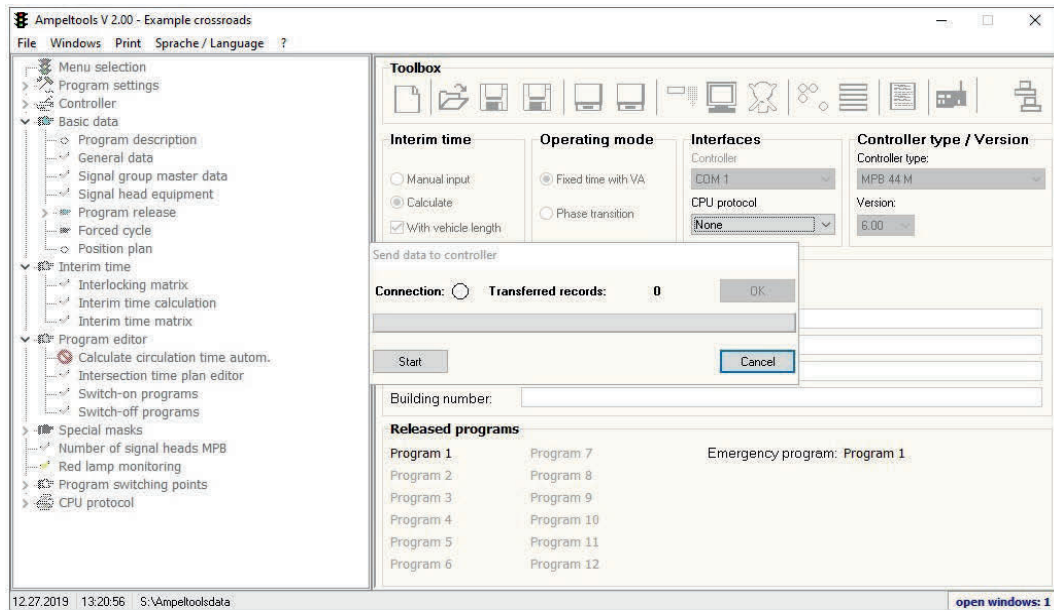

Press **Start** for data transfer to begin.

A progress bar appears while data transfer is active. If you receive an error message instead, please check the connection (controller type, PC lead, COM port, 12 groups interface switched on / correct setting).

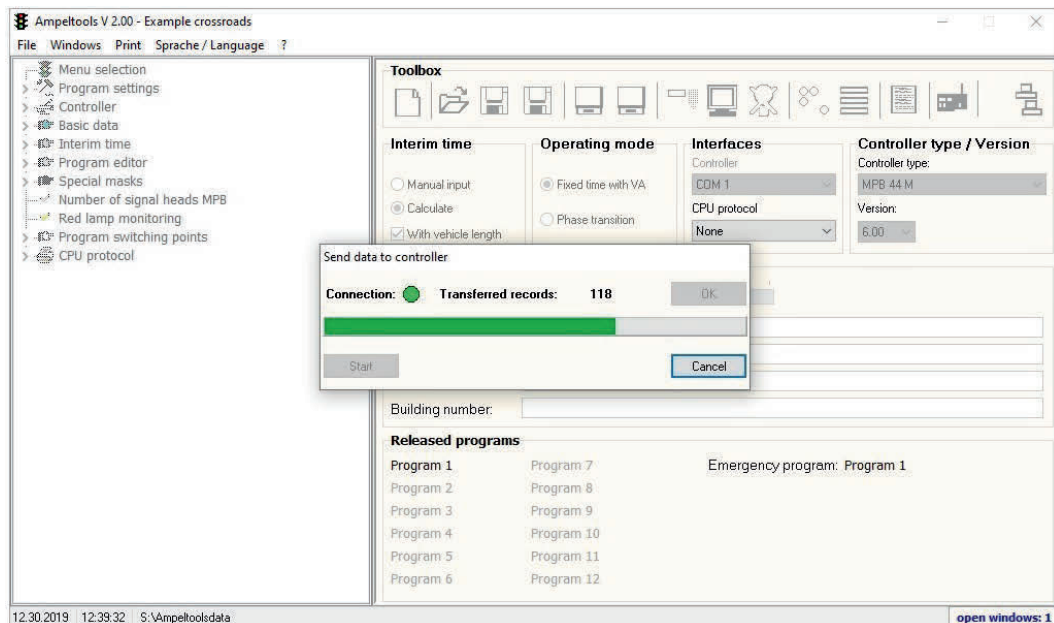

OK is enabled again once data transfer has been completed. Press to close the data transfer window.

See 4.2.5 for a detailed description of the 12 groups interface manual.

Step 20:

Load saved data

Click on **Load data** to load a saved file.

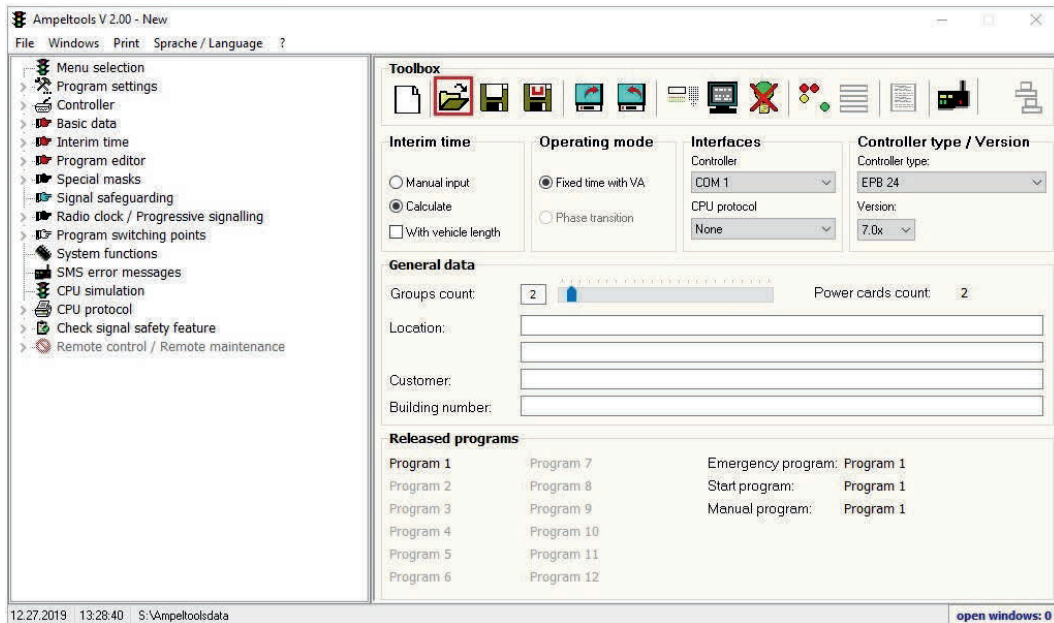

The dialogue box opens and you can select the required file.

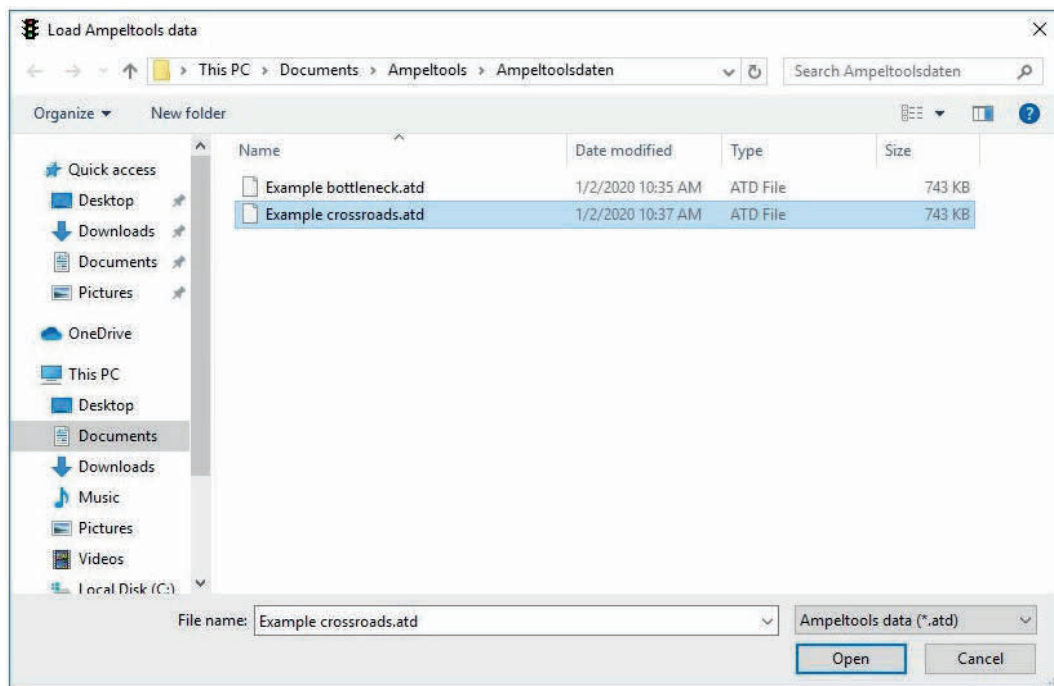

Click on **Open** to start loading the required data; a progress bar appears.

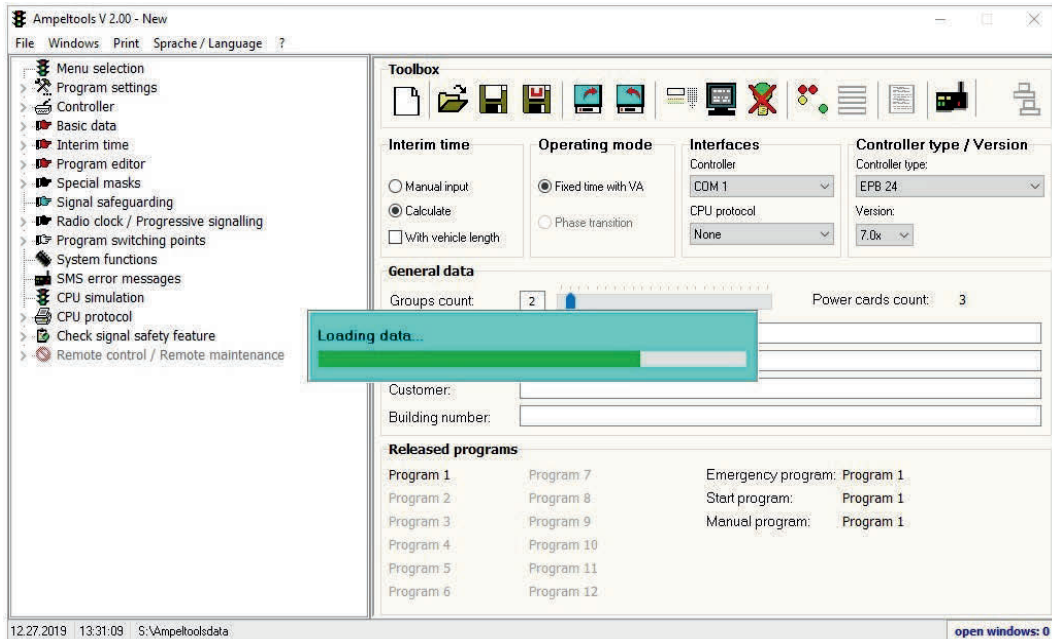

When the data have been loaded, the file name appears in the main window. The loaded program can now be edited or amended. See 4.2.2 for a detailed description.

Step 21:
Create map

To create a map, please use a corresponding drawing program. You can use the integrated drawing module if you only want to create a map that is not to scape. See 6.1.9 for a detailed description.

Step 22:
Create new program

Select **New** to create a new program. Please note that it is possible for all currently existing data or changes to be rejected. Please save these data first. You may possibly see a query whether the existing data should now be saved.

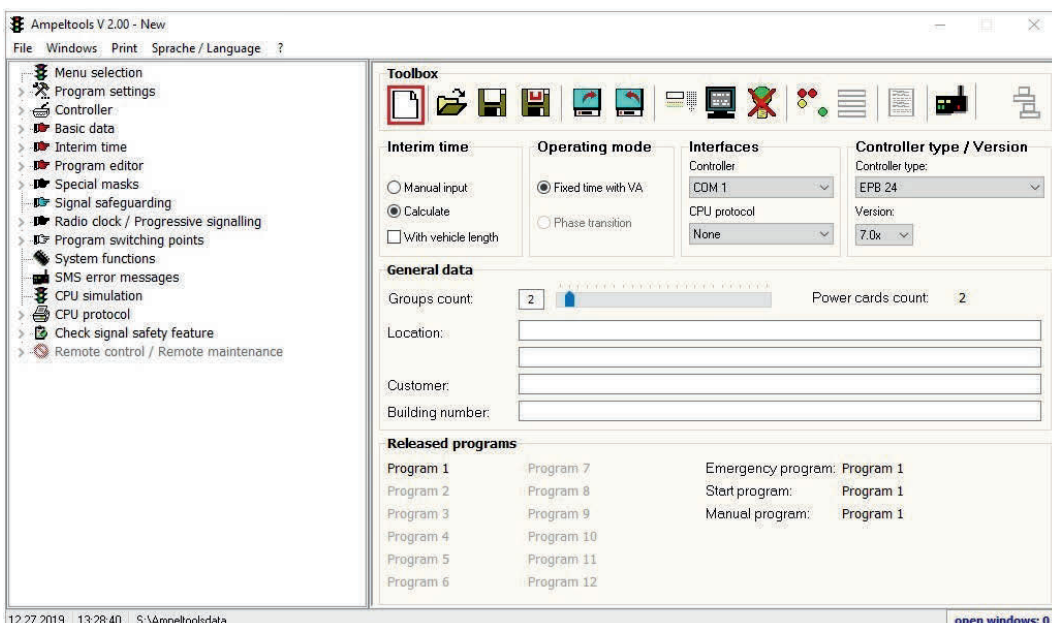

11.3 Calculation example for entering a crossroads system

A crossroads system is entered in the same way as the T-junction system, see 13.2. Depending on the number of required signal groups, adjust the entries in the corresponding entry masks for the corresponding number of signal groups.

11.4 Calculation example for entering a pedestrian traffic light system

Step 1:

Start Ampeltools. Select the required controller type and version in the main window. Fill in the details for the specific construction site in **General data**.

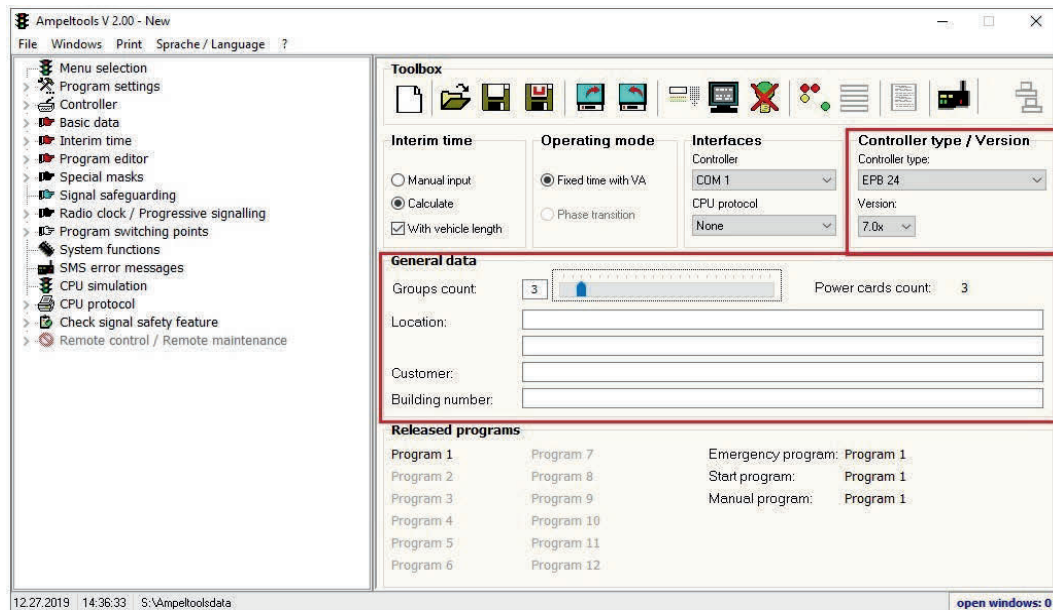

Change the number of groups in **Number of groups** to 3. Confirm whether vehicle lengths should be used for calculation with **Yes** and confirm with **OK**.

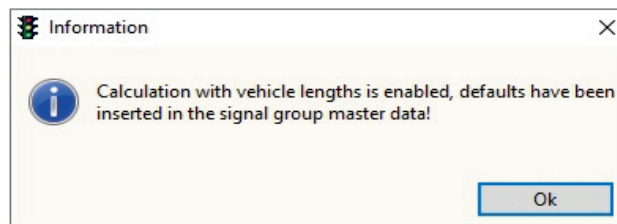
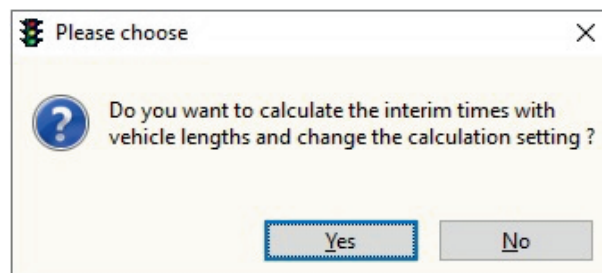

Note:

According to RiLSA, vehicle lengths must be included in calculations of interim times for crossing traffic flows. If you do not want this, confirm with **No**.

Step 2:
Open **General data**.

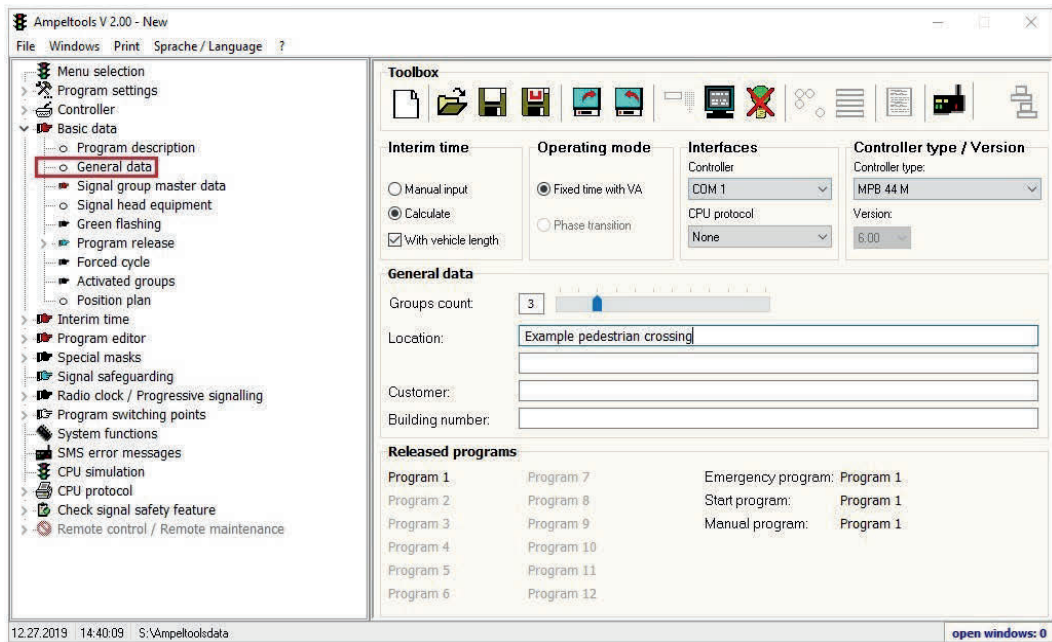

Fill in the details for the specific construction site in the input boxes.

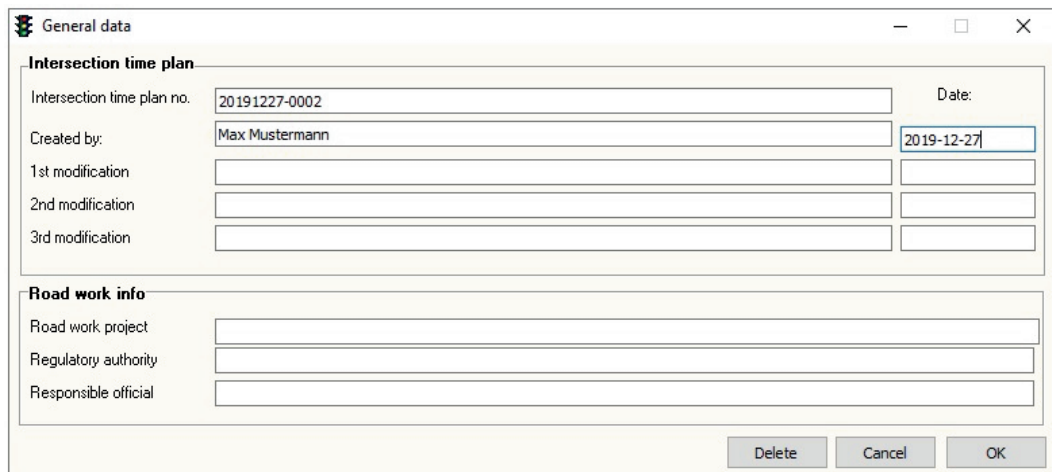

See 6.1.2 for a detailed description.

Step 3: Open Signal group master data

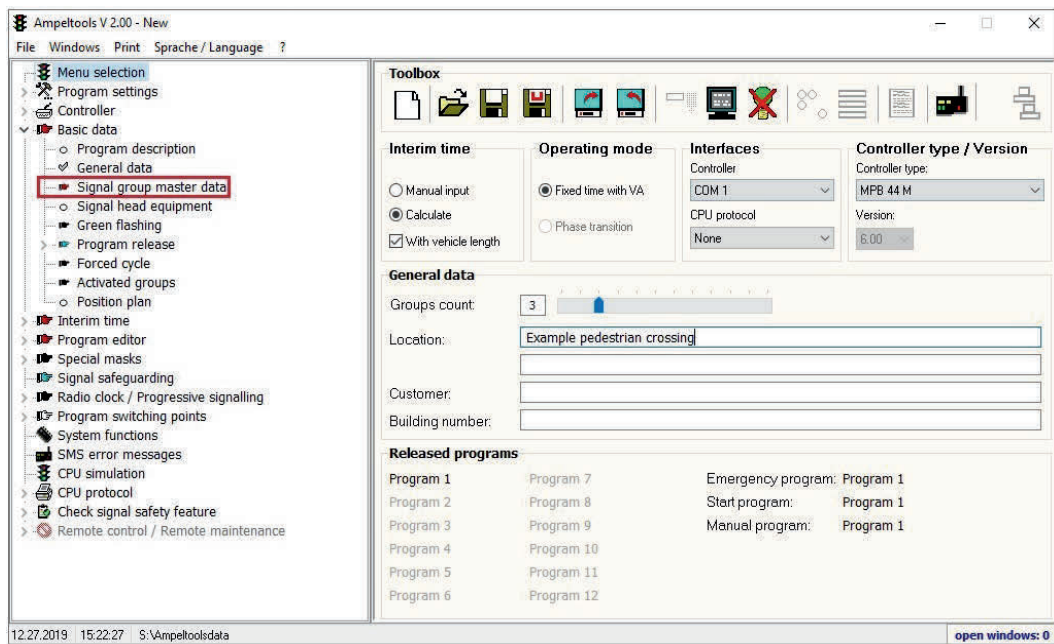

Enter the signal group name, red-yellow, yellow, minimum release times and calculation parameters for every signal group.
 The details should be entered according to the RiLSA or as required by the responsible authority.
 Do not tick **Flashing** for the vehicle groups (according to RiLSA 2015 there is no flashing for pedestrian systems) and tick **Request** for the pedestrian group.
 If there should be fixed switching of the pedestrian group in the cycle, do not tick **Request**.

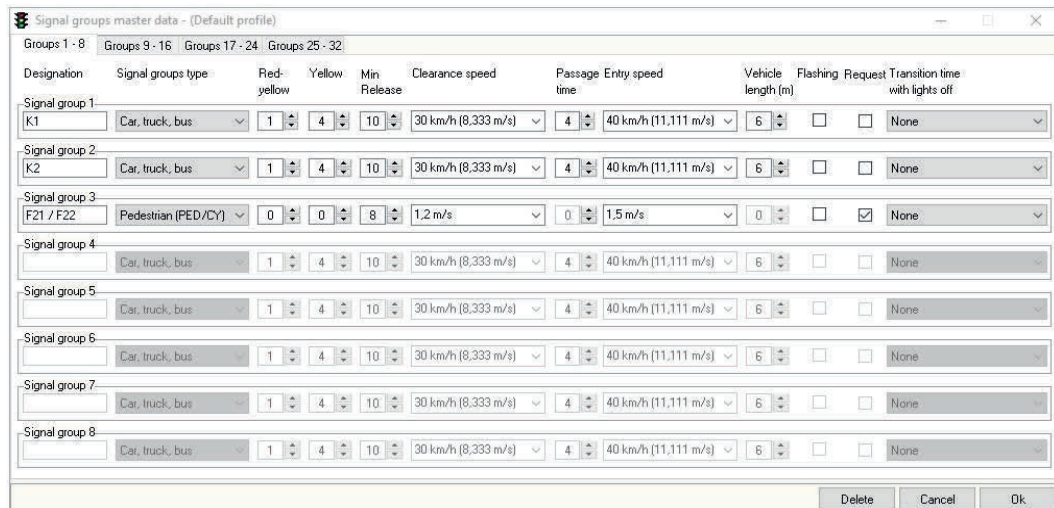

See 6.1.3 for a detailed description.

As soon as **Request** has been ticked for a signal group, the following mask opens automatically. The **Forced cycle** function is configured here. As a rule, the **Forced cycle** is disabled for pedestrian systems.

Program		Program	
1	<input checked="" type="checkbox"/> Activated every 5 minutes	7	<input checked="" type="checkbox"/> Activated every 5 minutes
2	<input checked="" type="checkbox"/> Activated every 5 minutes	8	<input checked="" type="checkbox"/> Activated every 5 minutes
3	<input checked="" type="checkbox"/> Activated every 5 minutes	9	<input checked="" type="checkbox"/> Activated every 5 minutes
4	<input checked="" type="checkbox"/> Activated every 5 minutes	10	<input checked="" type="checkbox"/> Activated every 5 minutes
5	<input checked="" type="checkbox"/> Activated every 5 minutes	11	<input checked="" type="checkbox"/> Activated every 5 minutes
6	<input checked="" type="checkbox"/> Activated every 5 minutes	12	<input checked="" type="checkbox"/> Activated every 5 minutes

Buttons: Delete, Cancel, Ok

See 6.1.7 for a detailed description.

Step 4: Open Signal head equipment

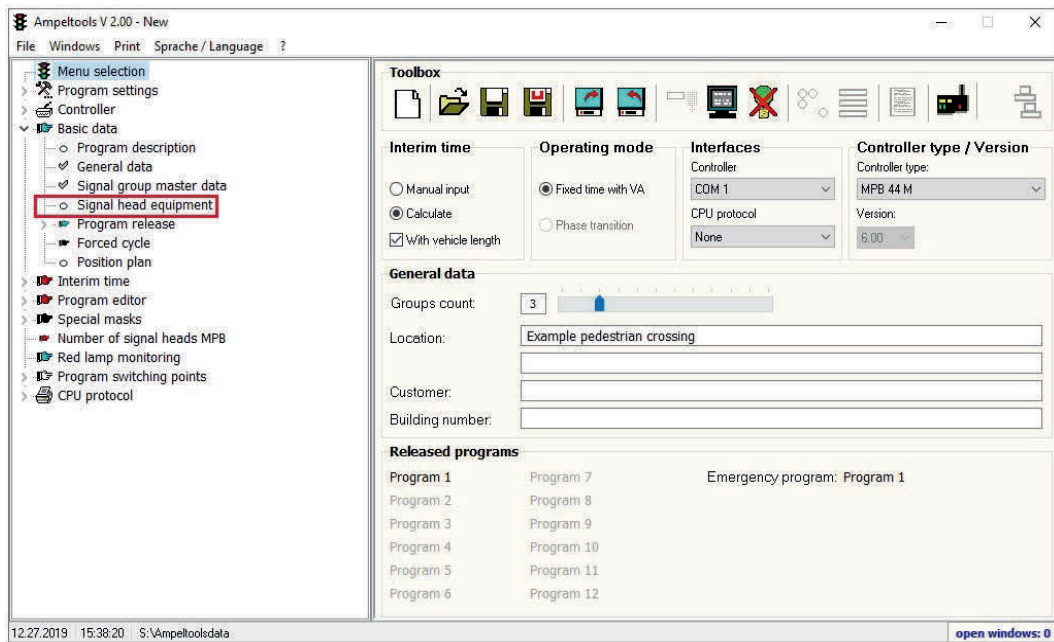

Select the respective equipment for every signal group.

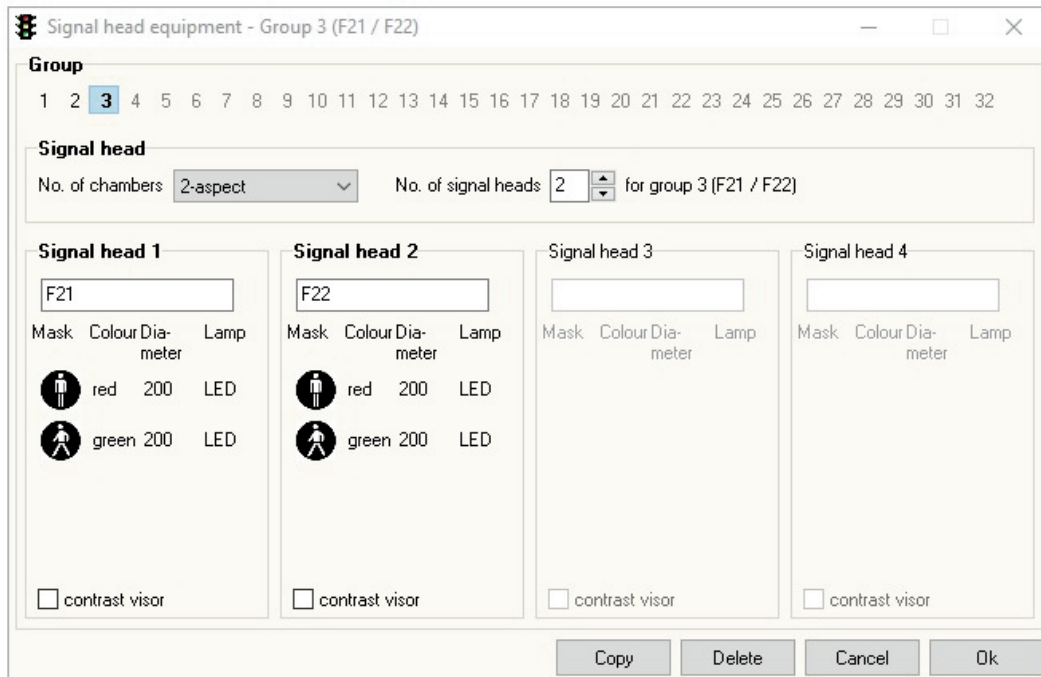

See 6.1.4 for a detailed description.

Step 5: Open Interlocking matrix

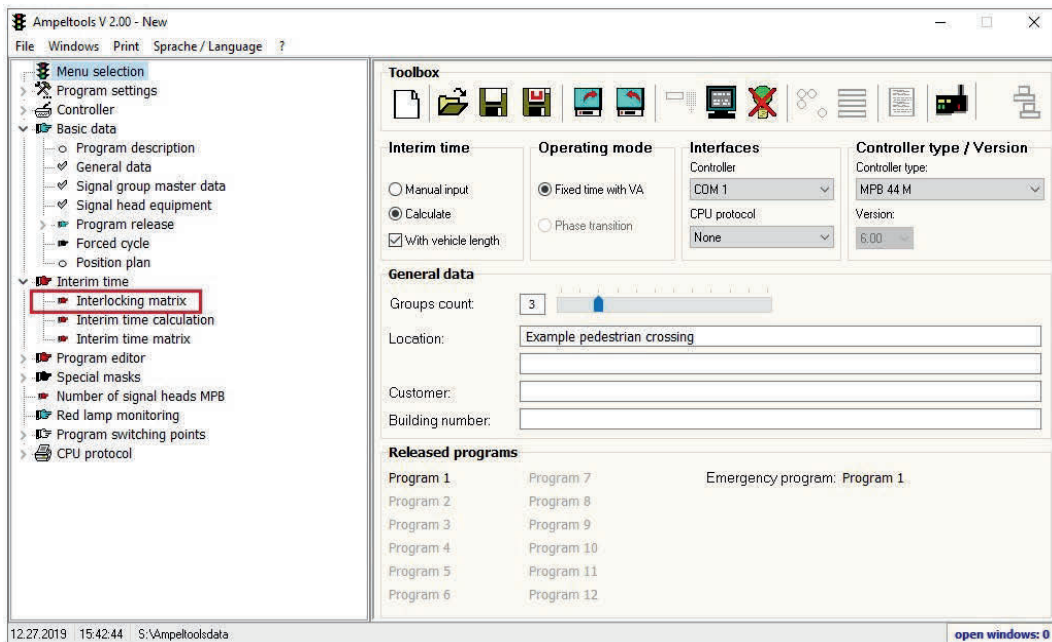

Do a double click with the left mouse button on those signal groups that are hostile to each other. The interim times are then calculated in each case.

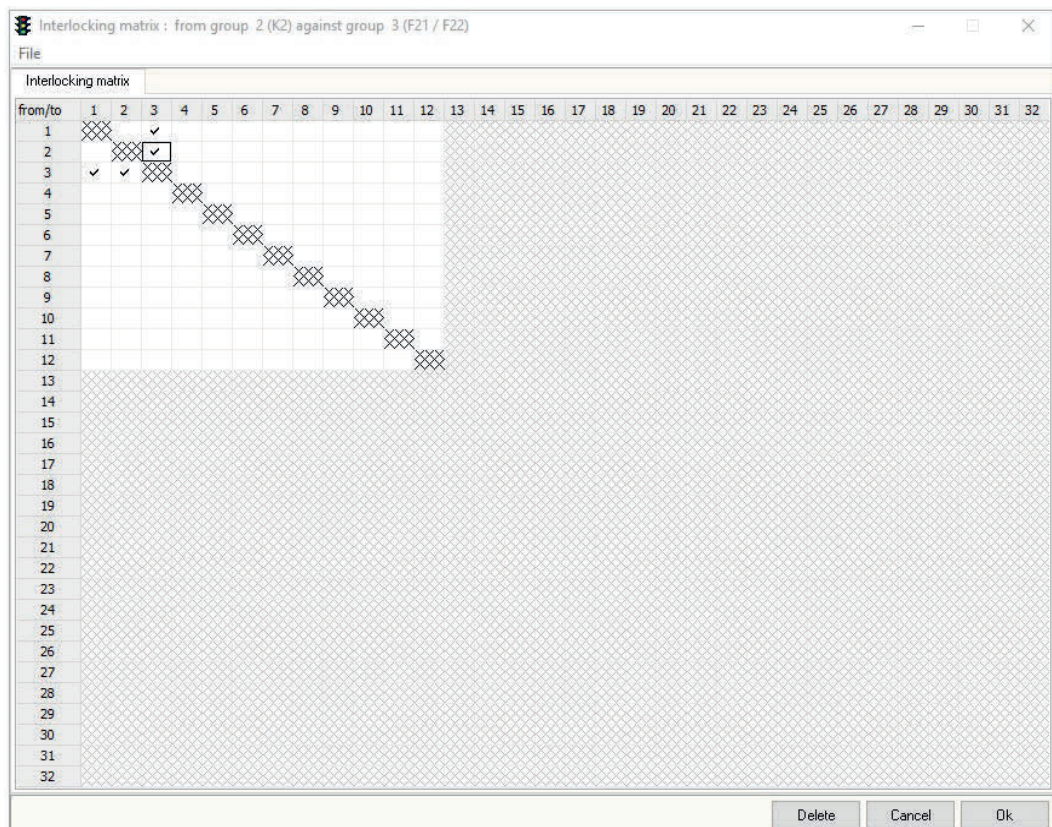

See 6.2.1 for a detailed description.

If data in this mask have been changed, a query appears when you close the mask whether the calculation mask should be opened. Please confirm with **OK**.

Step 6:

If **Interim time calculation** has not opened automatically, open it now manually.

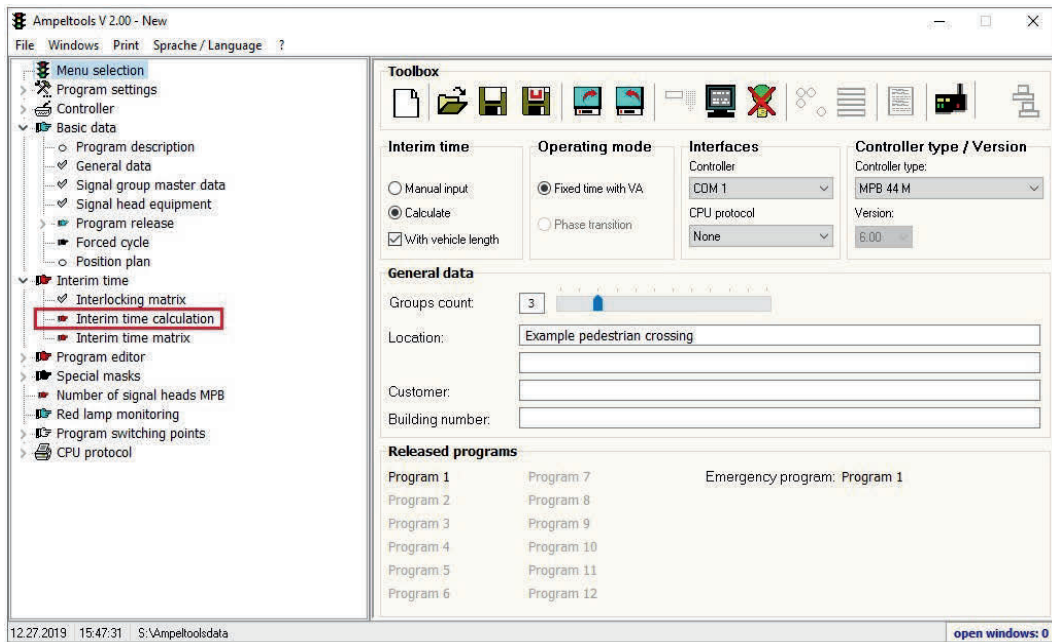

Enter the necessary data for interim time calculation for each clearance.

The calculation parameters are preset from the signal group master data, but can be adapted for every clearance.

Interim time calculation according to RiLSA

Signal device designation					Clearance time (tr)				Entry time			Tü	Interim time		
No.	End Green	Lane ID (C)	Start Green	Lane ID (E)	Crossing distance in meters	Vehicle length in meters	Clearance distance in meters	Clearance speed	Time in sec.	Entry distance in meters	Entry speed	Time in sec.	Crossing time in secs.	Tz calculated in secs.	Tz selected in secs.
1	K1		F21 / F22		6,00	6	12,00	30 km/h	1,440	0,00	1,5 m/s	0,000	4	5,440	6
2	K2		F21 / F22		6,00	6	12,00	30 km/h	1,440	0,00	1,5 m/s	0,000	4	5,440	6
3	F21 / F22		K1		12,00	0	12,00	1,2 m/s	10,000	0,00	40 km/h	0,000	0	10,000	10
4	F21 / F22		K2		12,00	0	12,00	1,2 m/s	10,000	0,00	40 km/h	0,000	0	10,000	10

Buttons: Delete, Cancel, OK

See 6.2.2 for a detailed description.

If closed with **OK**, the interim time matrix is produced automatically.

Step 7: Open Interim time matrix

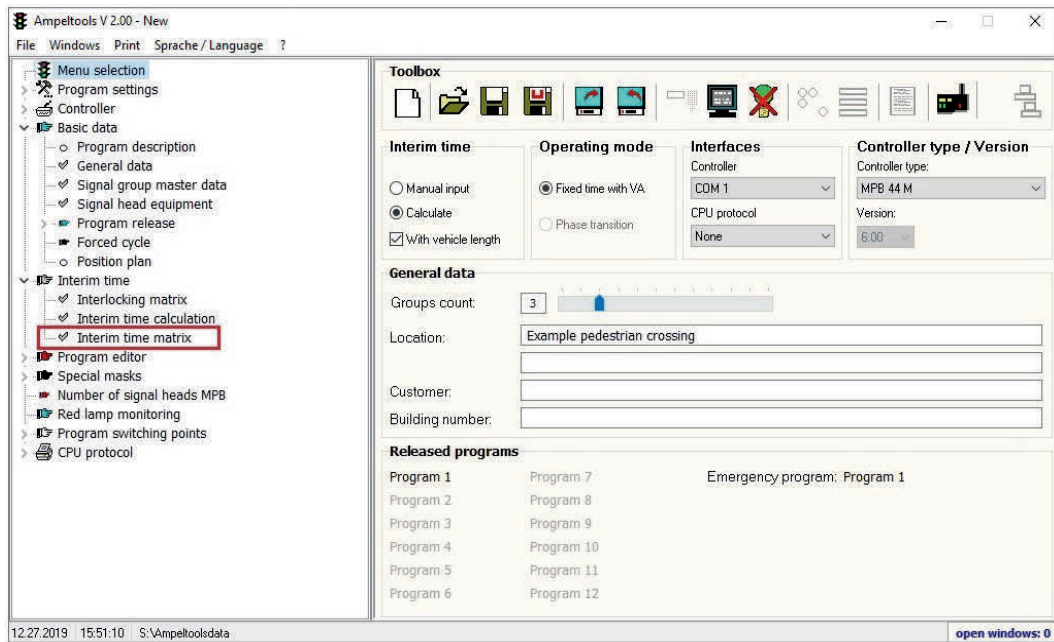

Here you can check the values taken from the interim time calculation. It is not possible to change them here.

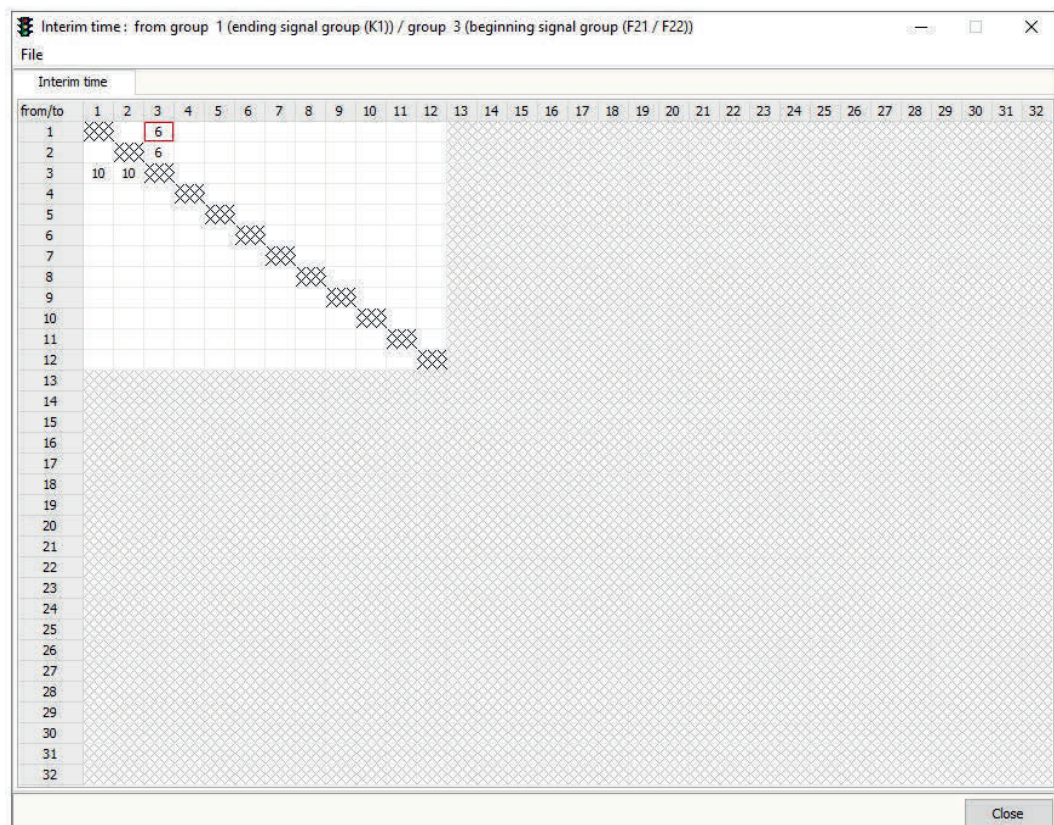

See 6.2.2 for a detailed description.

Step 8: Open Intersection time plan editor

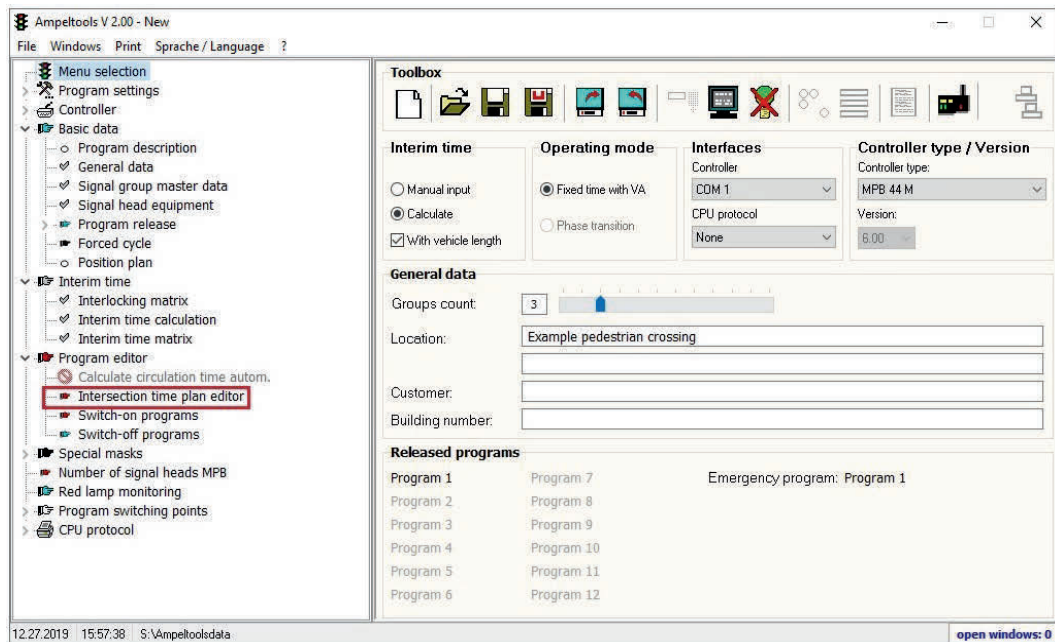

Step 9: Intersection time plan editor

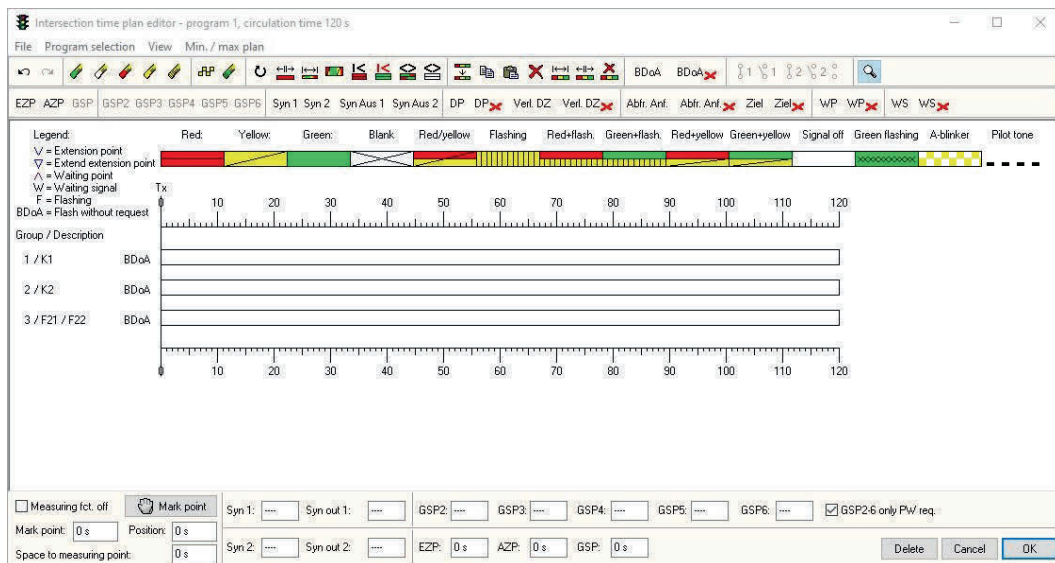

Create the minimum intersection time plan manually (see 6.3.4.1).

Please note a minimum holding time of 20 to 30 seconds for the road signal groups so that road traffic does not come to a complete halt with a permanent pedestrian request.

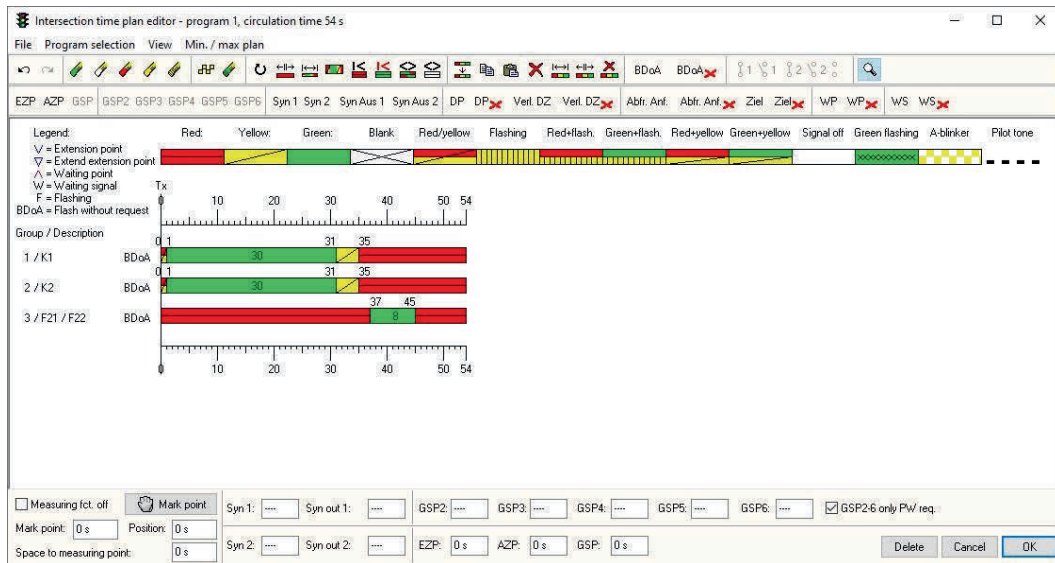

See 6.3.3 / 6.3.4 for a detailed description.

Step 10:

Select **Insert extension point** in the tool bar.

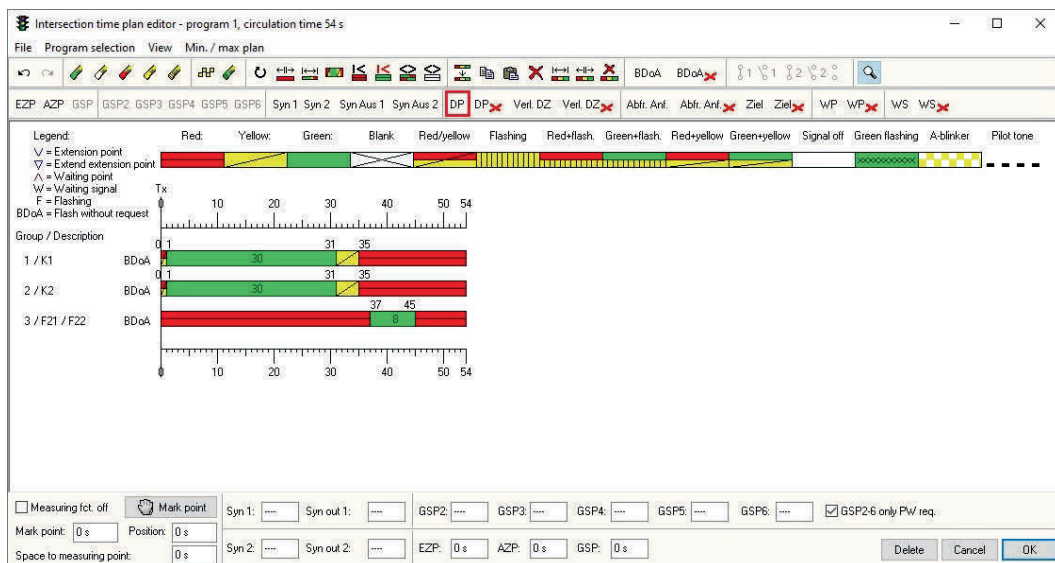

Position the extension point in the last-but-one green second of the first road signal group.

In the following entry window, enter 1 for **Extension time** and 3 for **Time gap**.

The screenshot shows the 'Intersection time plan editor' window. At the top, it displays 'Intersection time plan editor - program 1, Circulation time (min) 54 s / circulation time (max) 55 s'. Below the menu bar, there are various icons and a toolbar. The main area contains a legend and a signal timing diagram. A dialog box titled 'Extension group 1' is open, showing 'Extension time' set to 1 and 'Time gap' set to 3. The background diagram shows a signal cycle with a notch at 30 seconds for group 1.

Close with **OK**. The extension point is shown as a notch.
It should look like this:

The screenshot shows the 'Intersection time plan editor' window after the extension point has been added. The signal timing diagram now shows a notch at 30 seconds for group 1, which is highlighted with a red circle. The background diagram shows a signal cycle with a notch at 30 seconds for group 1.

Step 11:
Select **Extend extension point** in the tool bar.

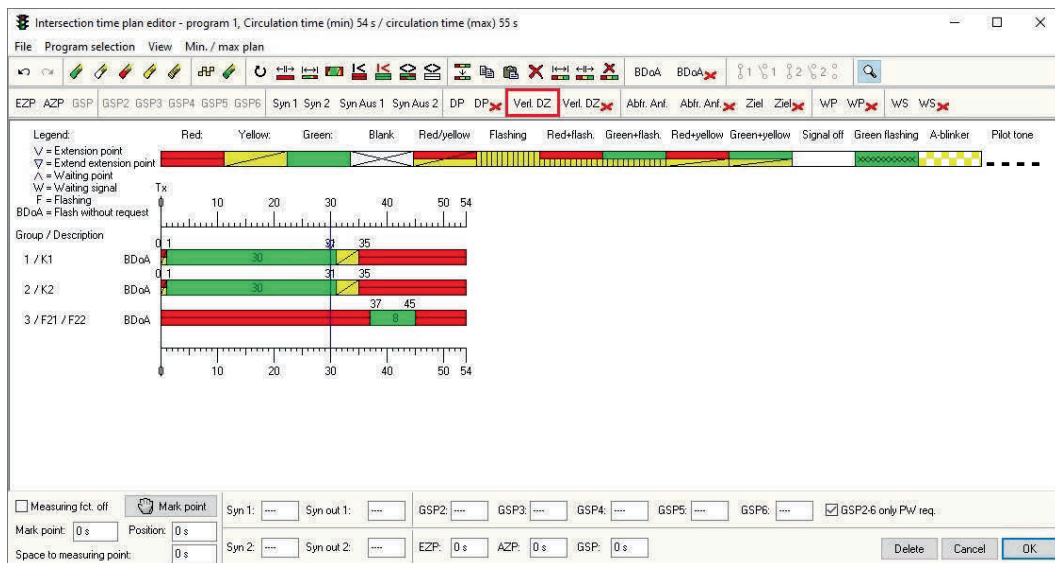

When the function is switched on, click on the existing extension point of signal group 1. This extension point is then shown closed at the top.

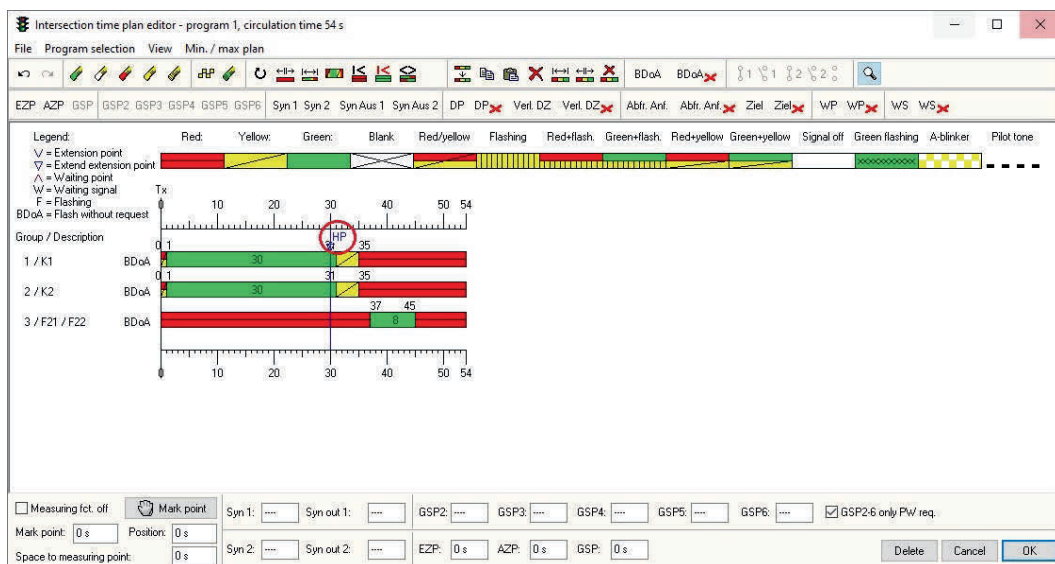

The effect of the functions in step 10 and 11 is that the road signal groups remain at green until a pedestrian request comes.
Leave these two steps out for a fixed cycle.

See 6.3.6.5 for a detailed description

Step 12:
 Select **Query request** in the tool bar.

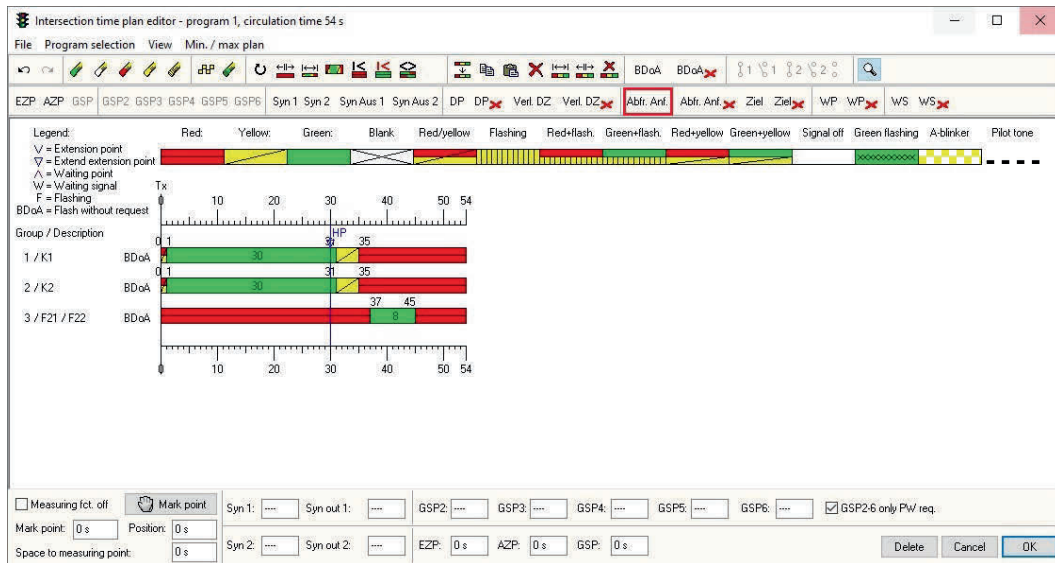

Set the query point one second before green begins in the pedestrian group with a **Q**.

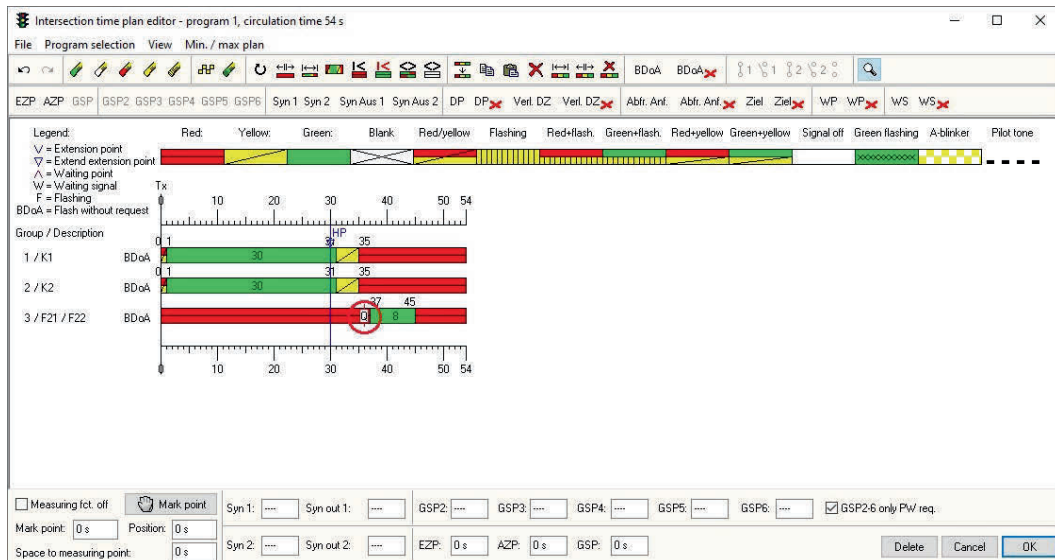

See 6.3.6.3 for a detailed description

Leave this step out for a fixed cycle.

Step 13:
Insert ON time
Click on EZP

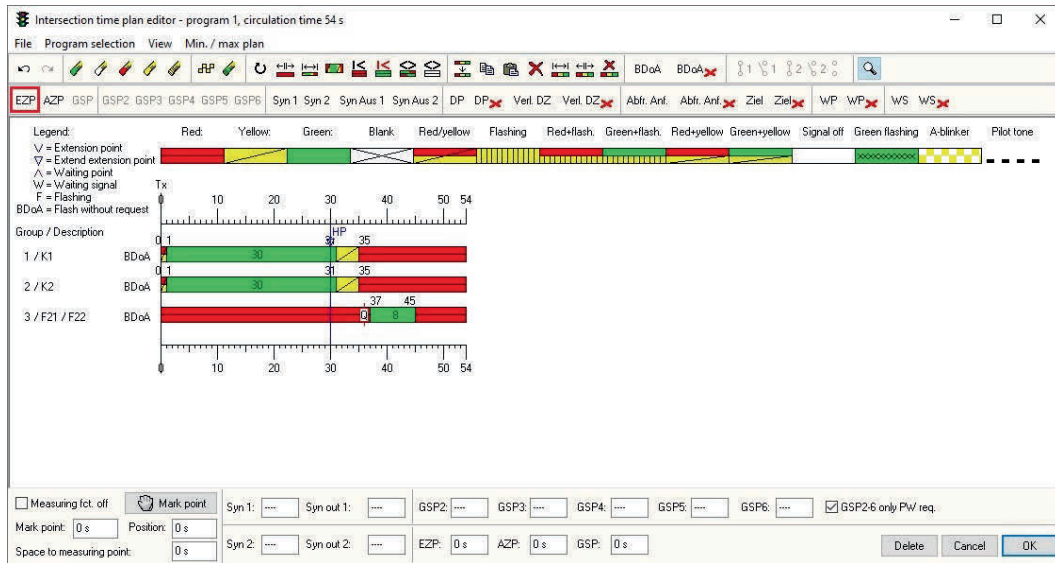

Mark the required ON time by clicking the mouse in the required second of the cycle. As a rule, in pedestrian traffic light systems this is always in the main direction green; second 15 in our example.
 The EZP adjusted in this way is then shown below in the intersection time plan editor.

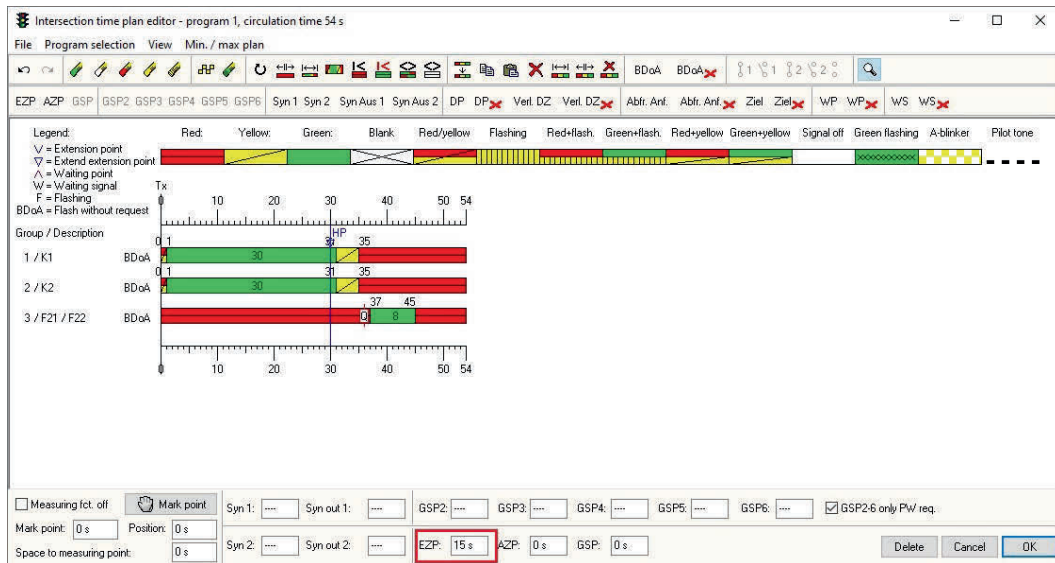

See 6.3.4.8 for a detailed description

Step 14:
Insert OFF time
Click on AZP

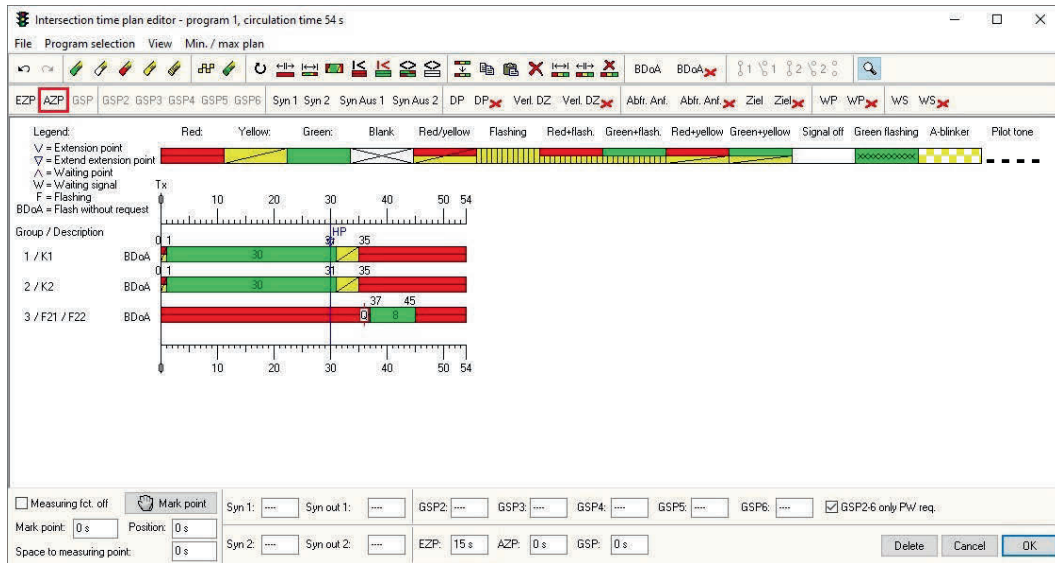

Mark the required OFF time by clicking the mouse in the required second of the cycle. As a rule, in pedestrian traffic light systems this is always in the main direction green; second 15 in our example. The AZP adjusted in this way is then shown below in the intersection time plan editor.

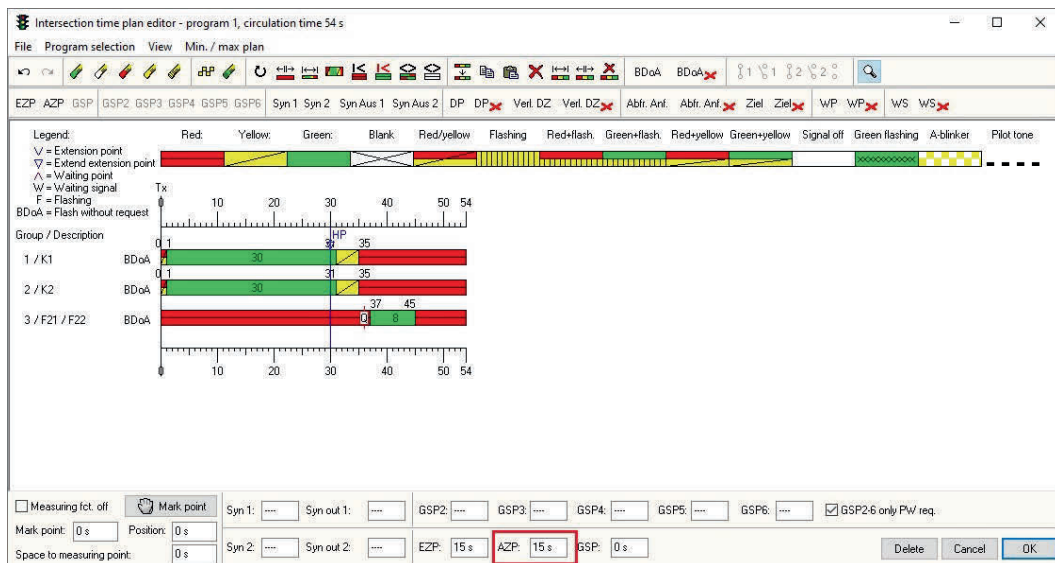

See 6.3.4.9 for a detailed description

For controller type MPB4xxx, a message about checking signal safeguarding appears on closing the mask.

Here you can check the preset red lamp monitoring function, adjust if necessary and close with **OK**.

Prg./Grp.	1	2	3	4	5	6	7	8	9	10	11	12	13	14	15	16	17	18	19	20	21	22	23	24
P1	✓	✓	✓																					
P2																								
P3																								
P4																								
P5																								
P6																								

See 6.6.4 for a detailed description.

Note:

If you are using a controller type EPB 12 / 24 / 48, the signal safeguarding mask does not open automatically and has to be selected manually.
See step 18.

Step 15: Open Switch-on programs

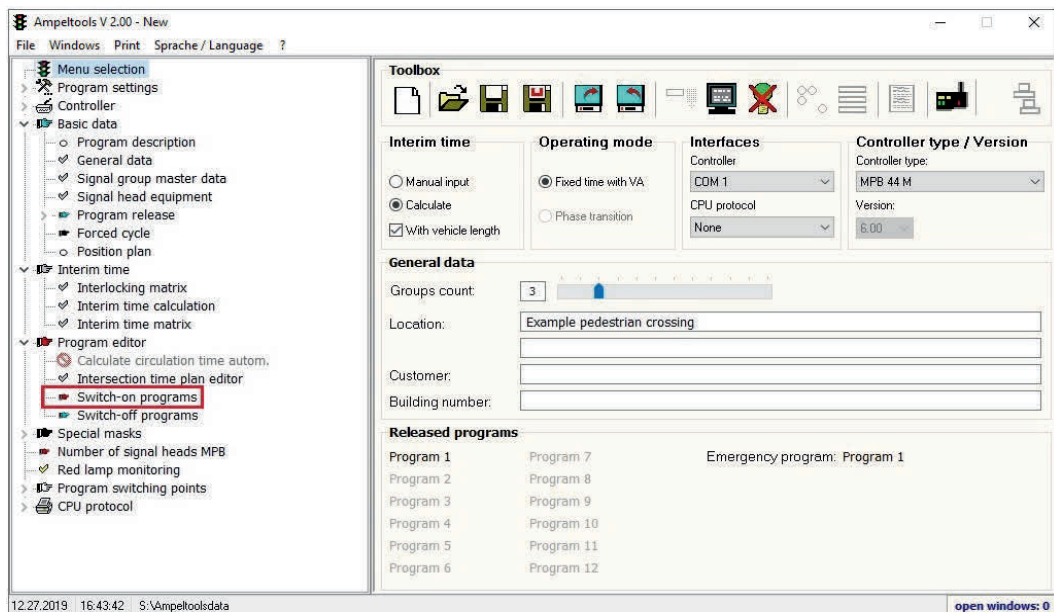

Enter the value shown as **Longest interim time in matrix** as step time for step 1

Enter step time **10** for step 2.

Nothing is entered for step 3.

These defaults correspond to a switch-on program according to the recommendation of RiLSA 2015.

However, if the responsible authority specifies another switch-on program, please adjust the switch-on program and ON point accordingly.

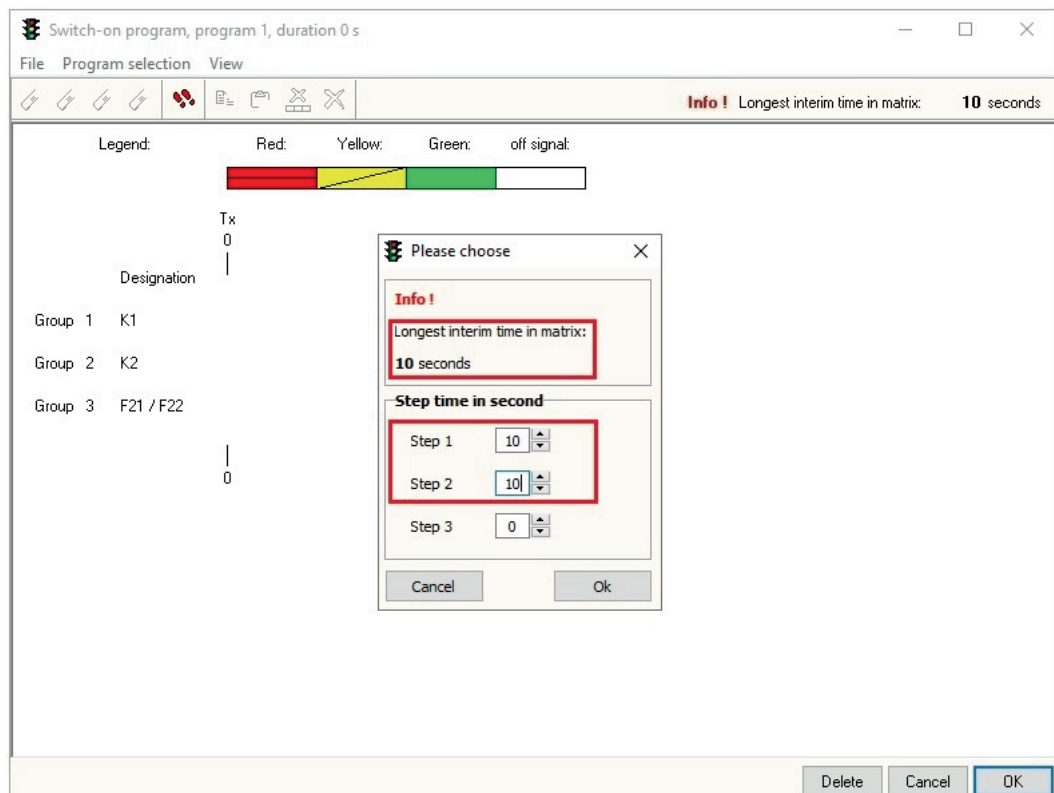

Confirm with **OK** to open the switch-on program editor. This has two areas according to the step time, separated by a dividing line.

The first 15 seconds from the ON time of the signal program are shown in the right area.

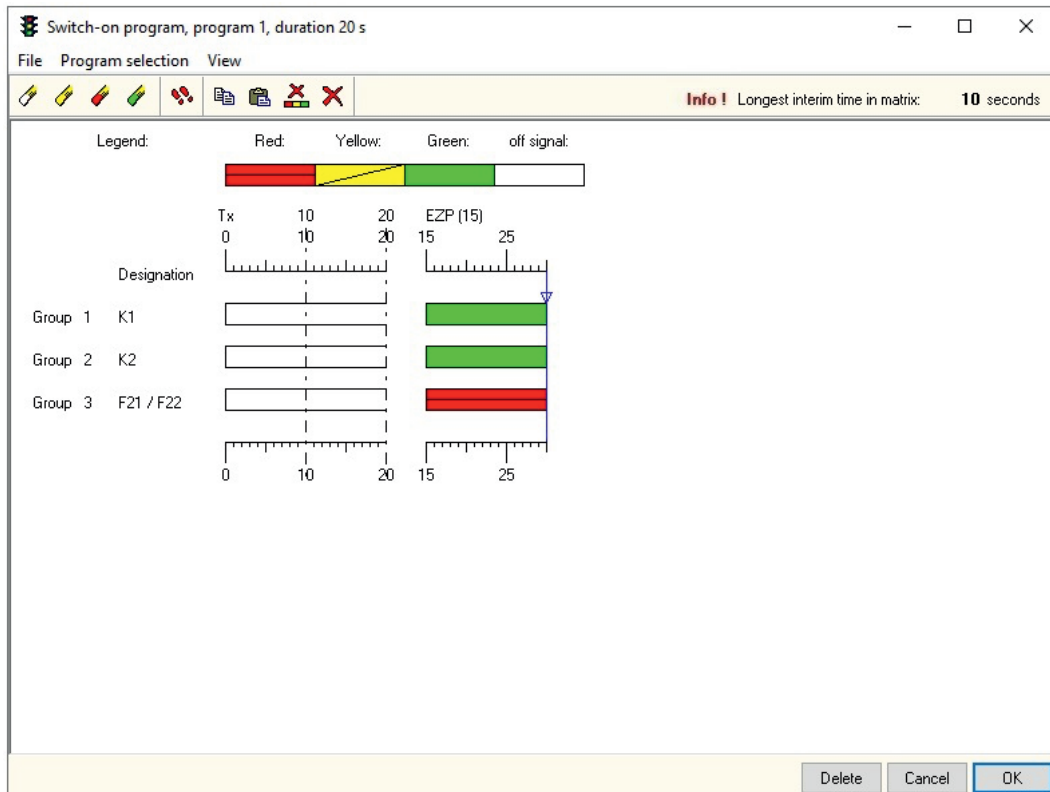

Select the red paintbrush with the left mouse button and click in both step markings for the pedestrian group one after the other. They change colour to red. Then select the green paintbrush and click in the second step marking for both road signal groups one after the other. They change colour to green.

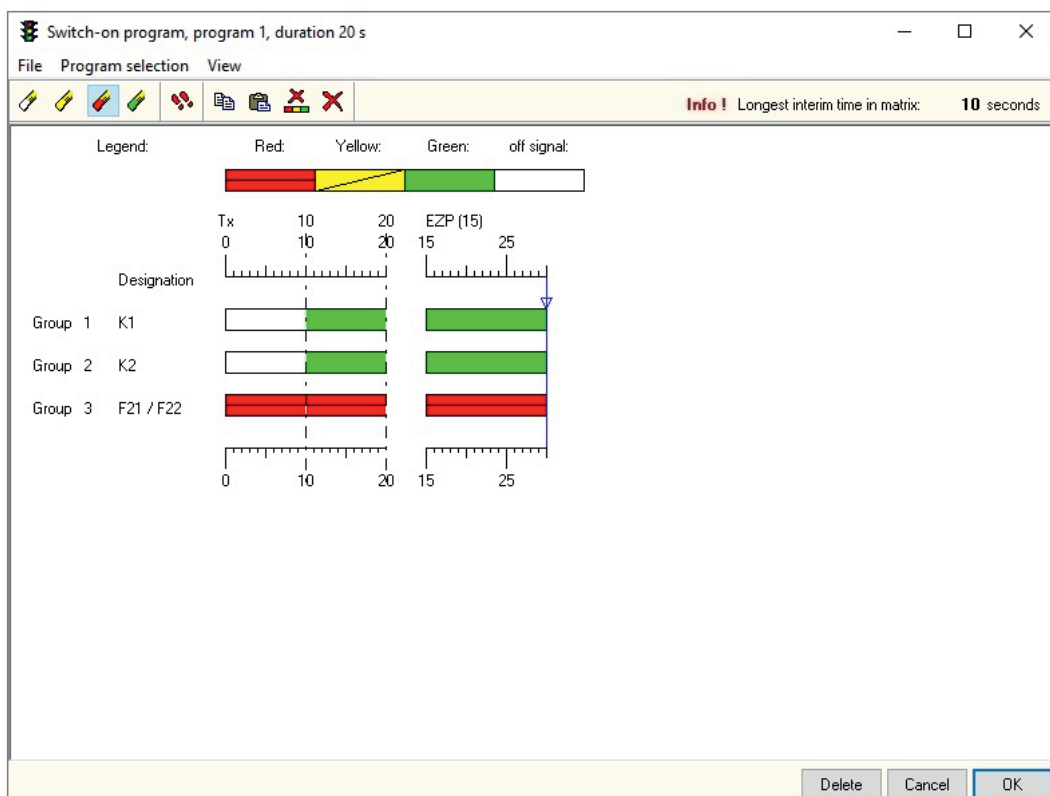

After creating the switch-on program, this (left area) should move on seamlessly to the ON point of the signal program (right area)
See 6.3.8 / 6.3.8.4 for a detailed description.

If you are using a controller type EPB 12 / 24 / 48, the switch-on program is created graphically (like the intersection time plan editor).

See 6.3.8.3 for a detailed description

Step 16: Open Switch-off programs

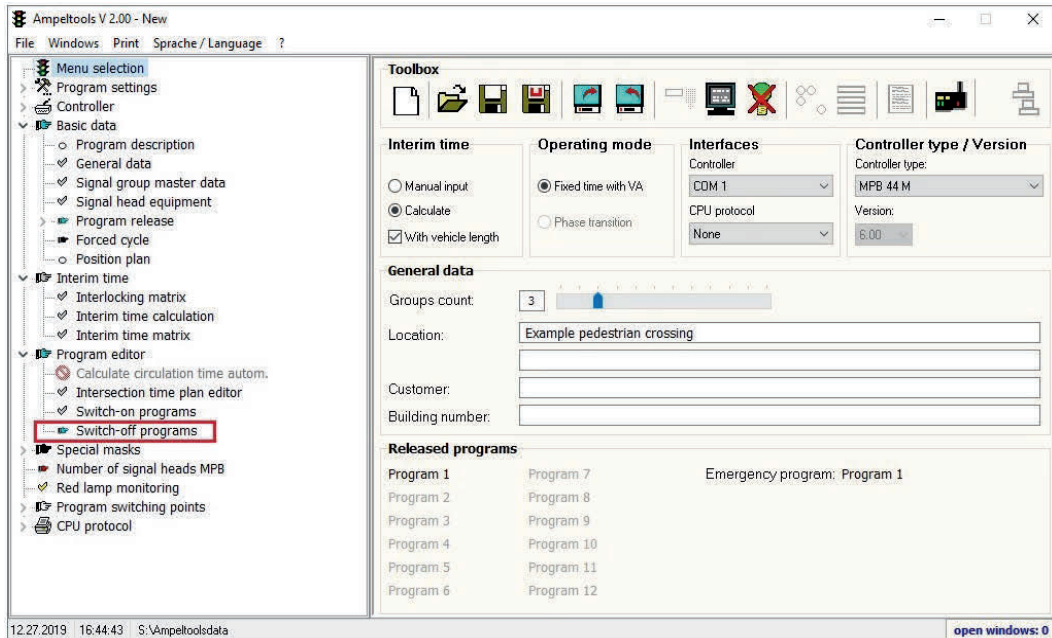

Enter step time **10** for step 1. For step 2, please enter the value shown as **Longest interim time in matrix**.

Nothing is entered for step 3.

These defaults correspond to a switch-off program according to the recommendation of RiLSA 2015.

However, if the responsible authority specifies another switch-off program, please adjust the switch-off program and ON point accordingly.

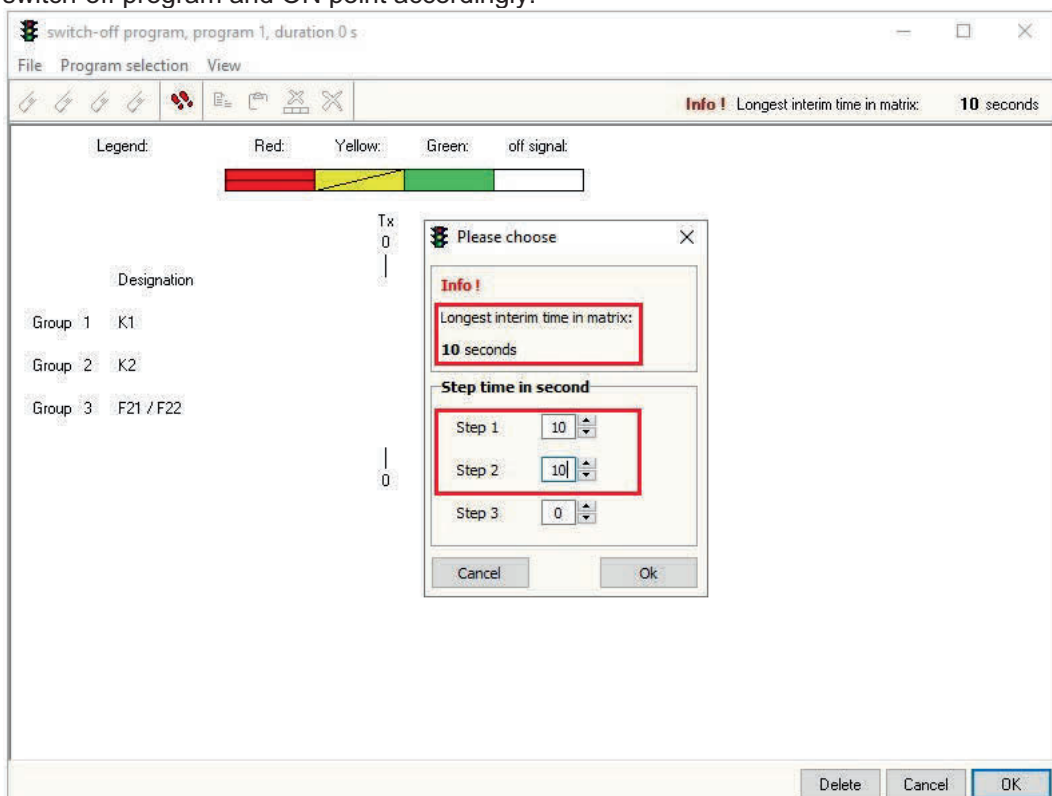

Confirm with **OK** to open the switch-off program editor.

The last 15 seconds from the OFF time of the signal program are shown in the left area.

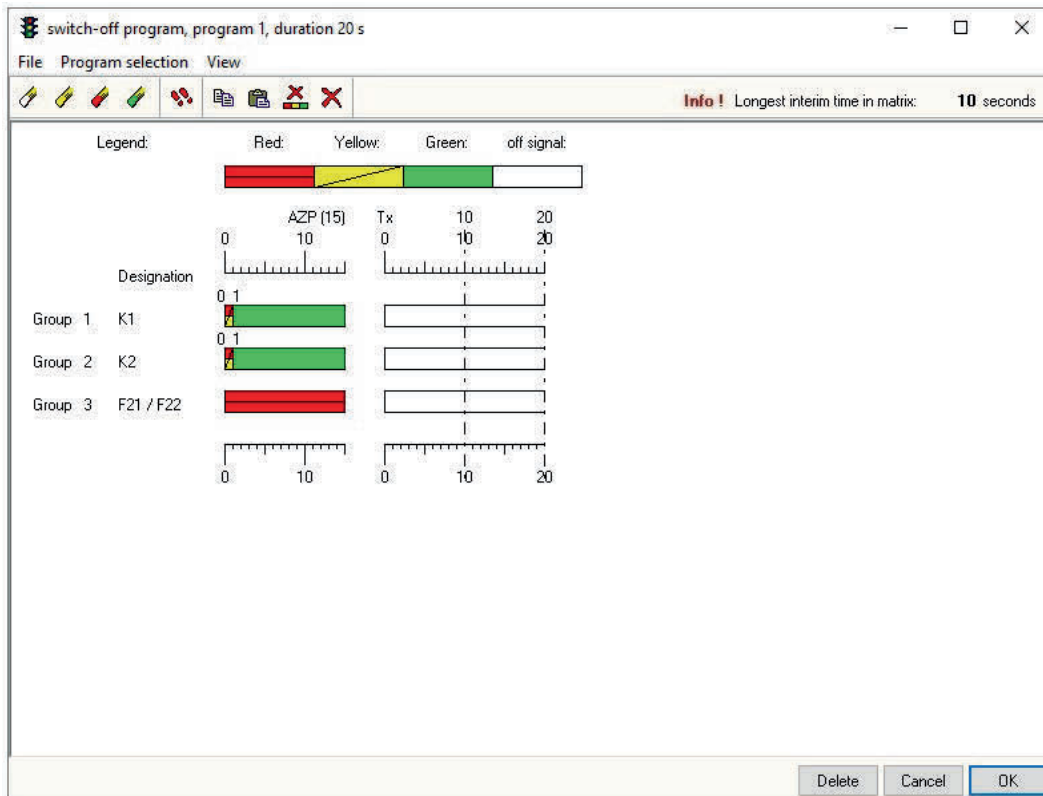

Select the red paintbrush with the left mouse button and click in both step markings for the pedestrian group one after the other. They change colour to red. Then select the green paintbrush and click in the first step marking for both road signal groups. They change colour to green.

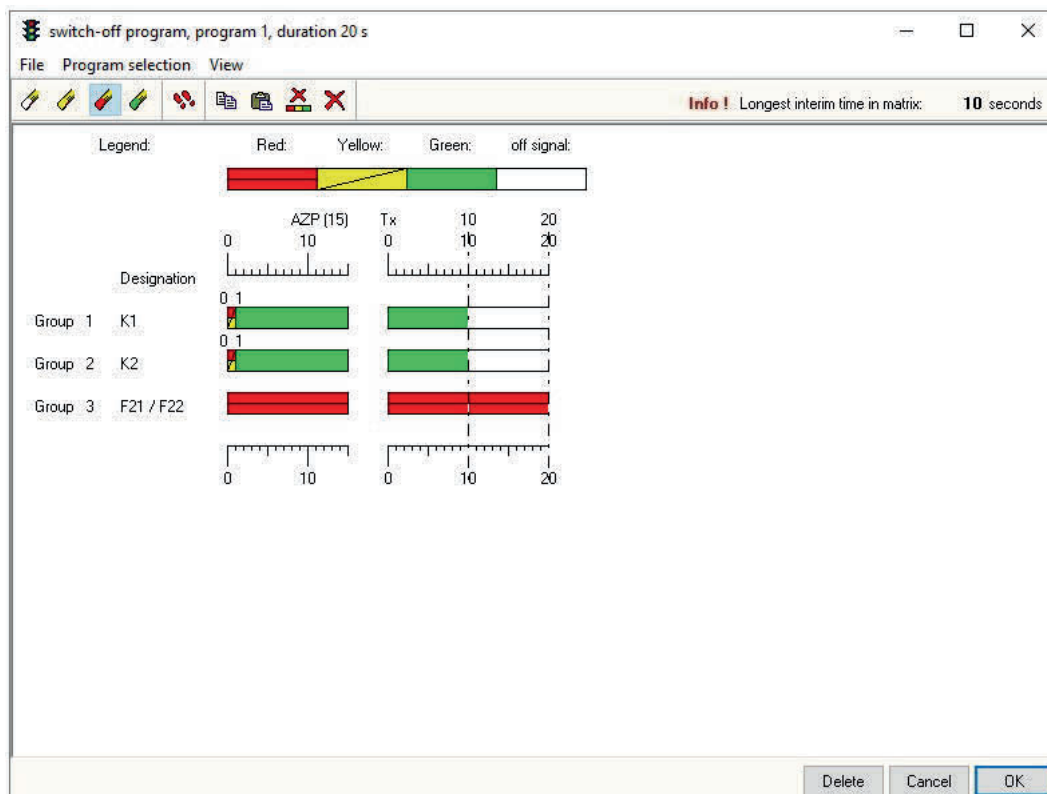

After creating the switch-off program (right area), this should move on seamlessly to the signal program (left area).

If you are using a controller type EPB 12 / 24 / 48, the switch-on program is created graphically (like the intersection time plan editor).

See 6.3.9 for a detailed description.

Step 17:
Open Number of signal heads MPB

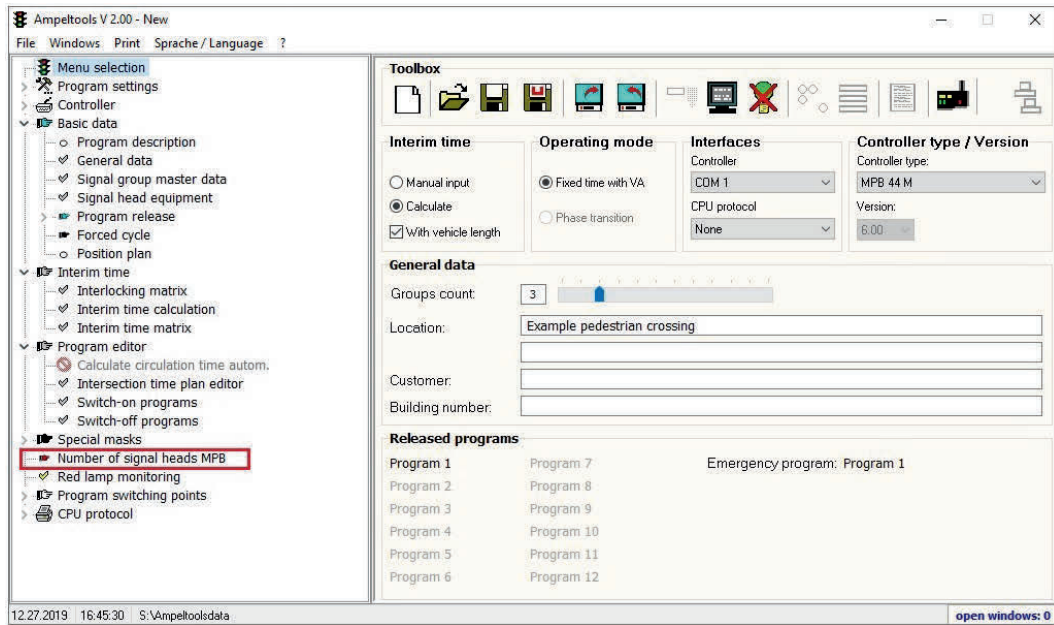

Here you can enter the number of signal heads with controller in each signal group.



See 6.5 for a detailed description.

Step 18:

Open "Signal safeguarding"

– only necessary for controller type EPB 12 / 24 / 48, otherwise continue with step 19.

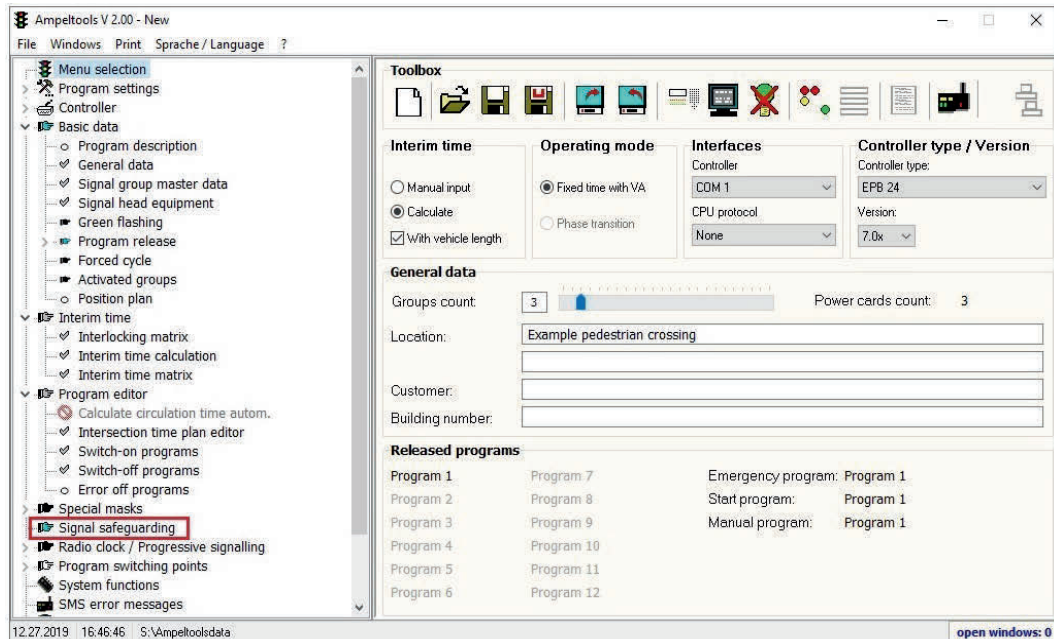

Here you can configure signal safeguarding for every signal group.

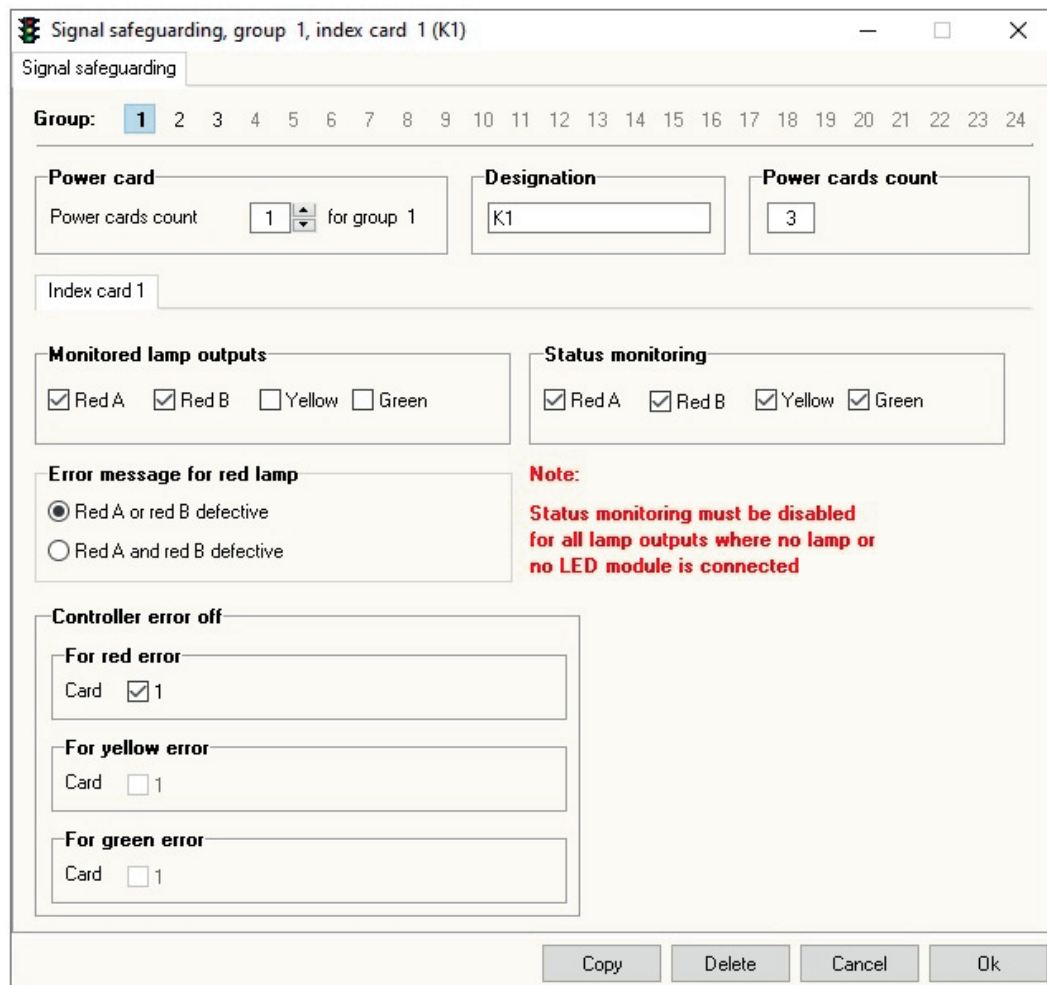

See 6.6.2 for a detailed description.

Step 19:
Save existing data
To save existing data, click on **Save data**.

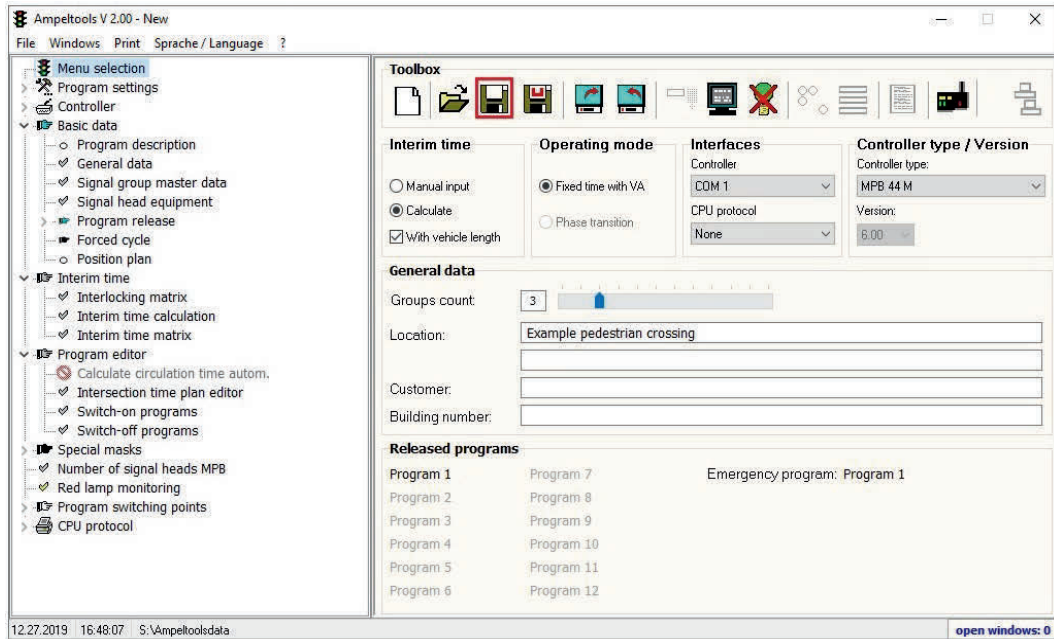

Please enter a file name for saving the program.

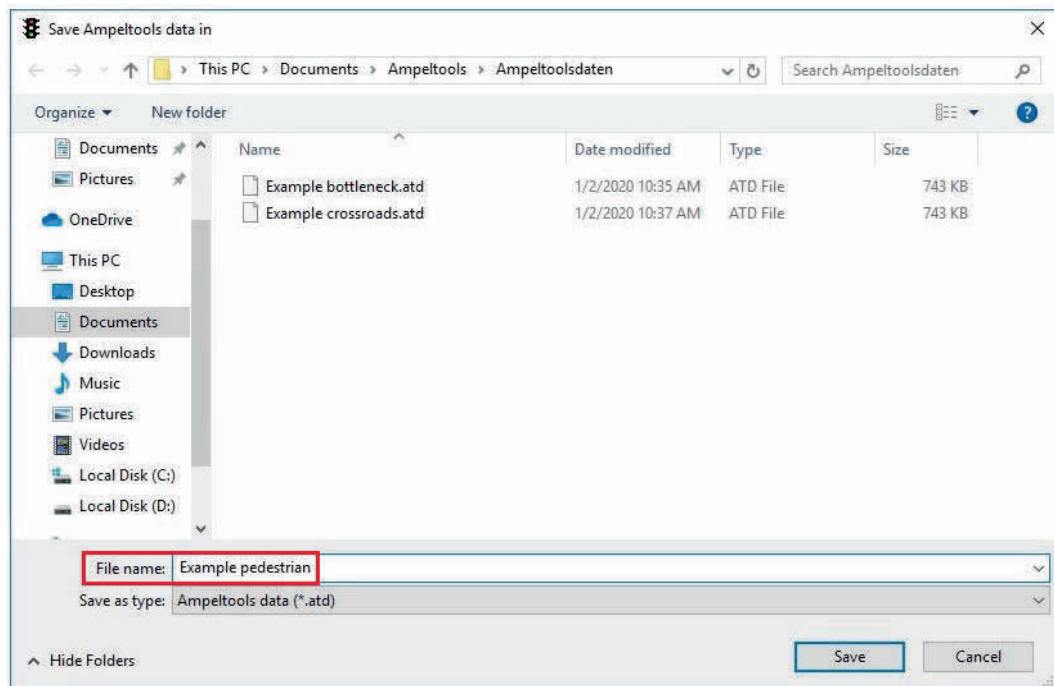

Confirm with **Save**.

The data will be saved accordingly with a corresponding progress bar.

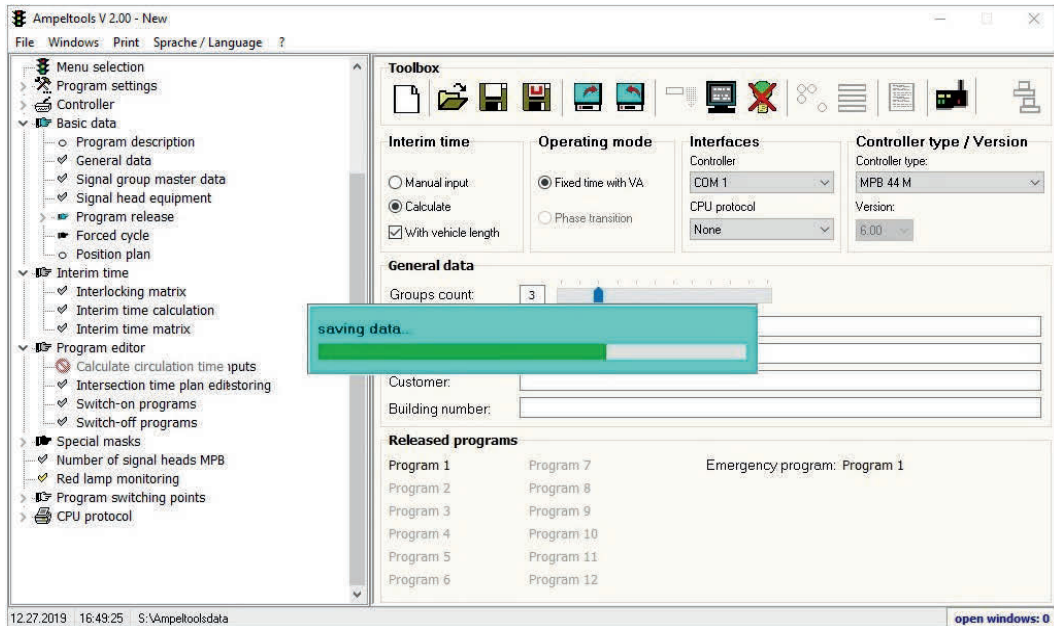

When the data have been saved, the file name appears in the main window.

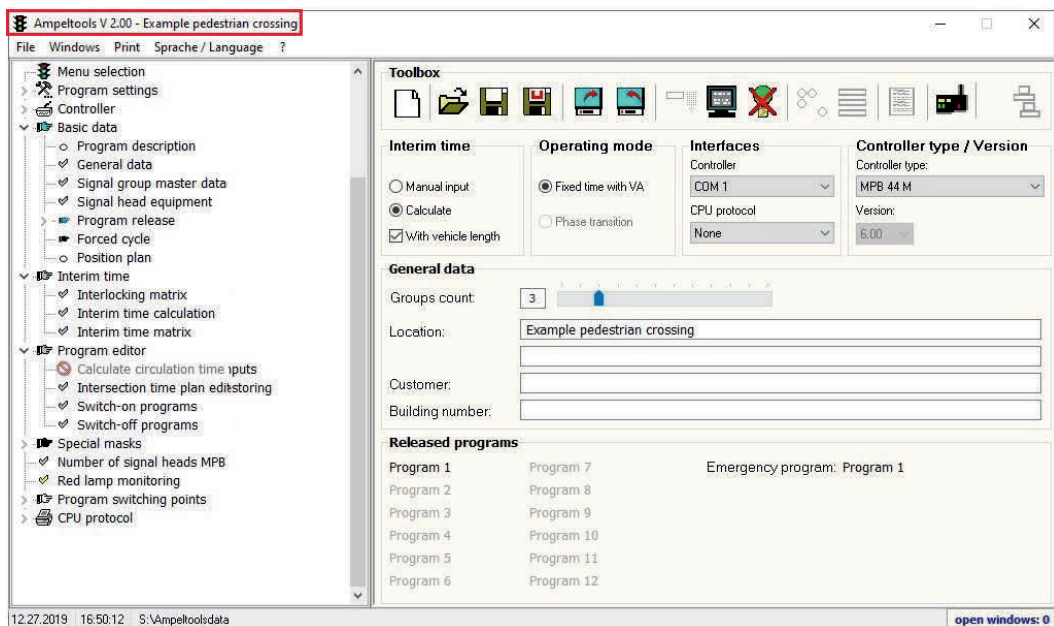

See 4.2.2 / 4.2.3 for a detailed description.

Step 20:

Print existing data

To print existing data, select the required function in the print menu or use **Print all**.

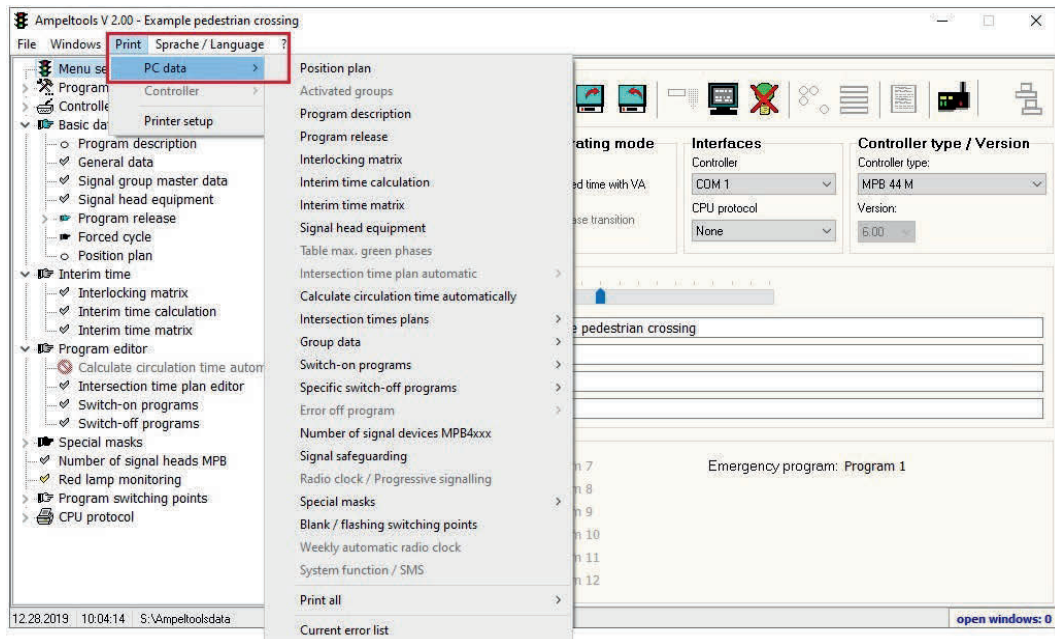

See 4.4.3 / 4.4.3.1.5 for a detailed description.

Step 21:

Data transfer to 12 groups interface

Select the corresponding serial interface for data transfer. If you use a USB serial converter, it should be plugged in before you start Ampeltools. Connect the USB serial converter with the corresponding PC lead and the 12 groups interface.

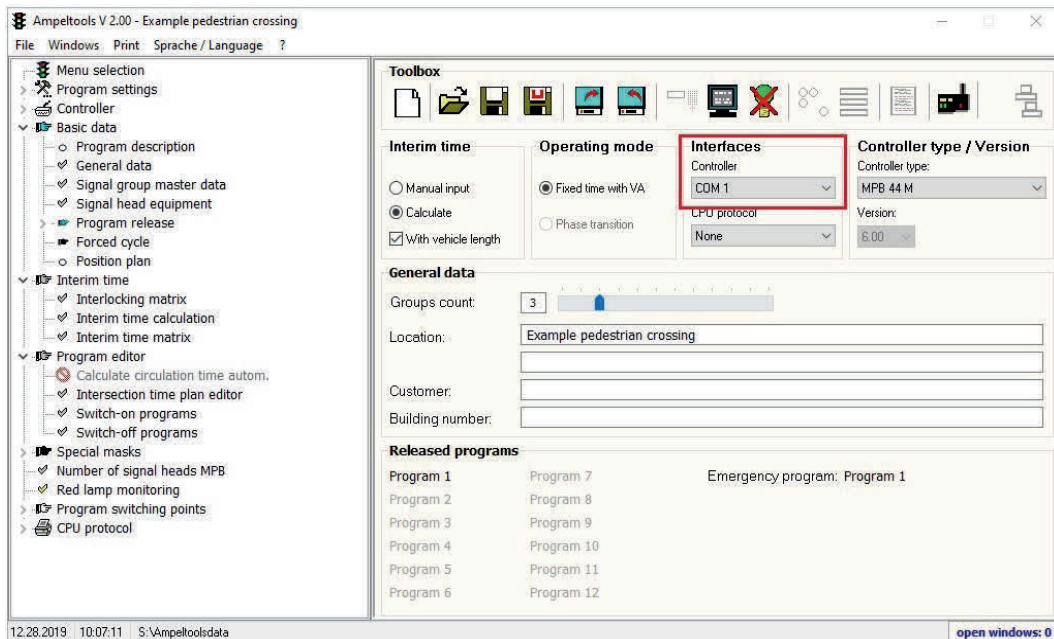

If no interface is selected, all data transfer functions are disabled.

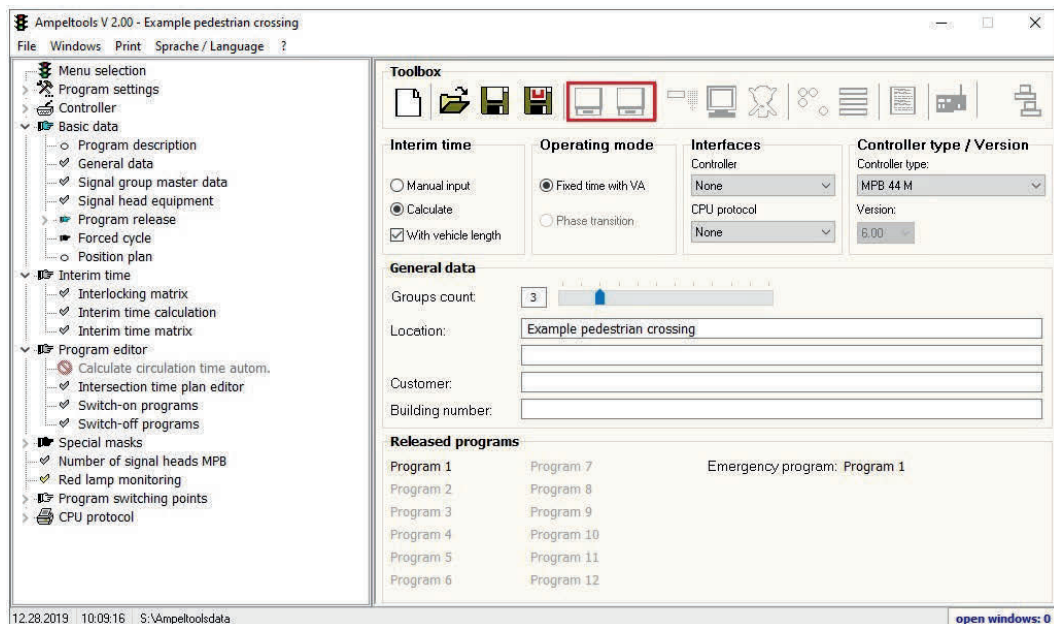

Select the corresponding setting for data reception at 12 groups interface

Press the corresponding button to start data transfer.

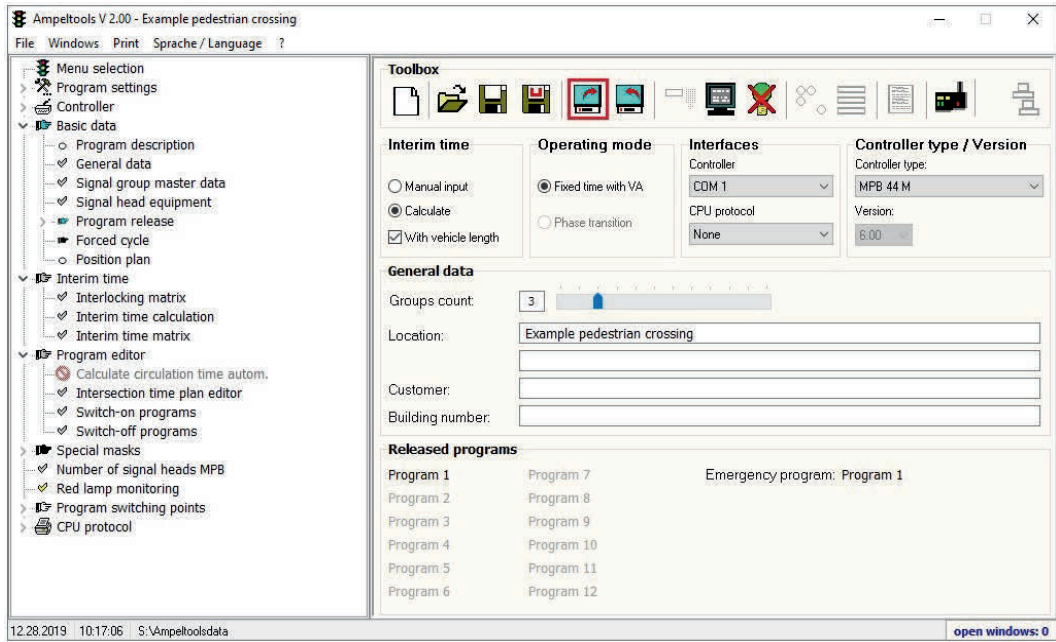

The data transfer window opens.

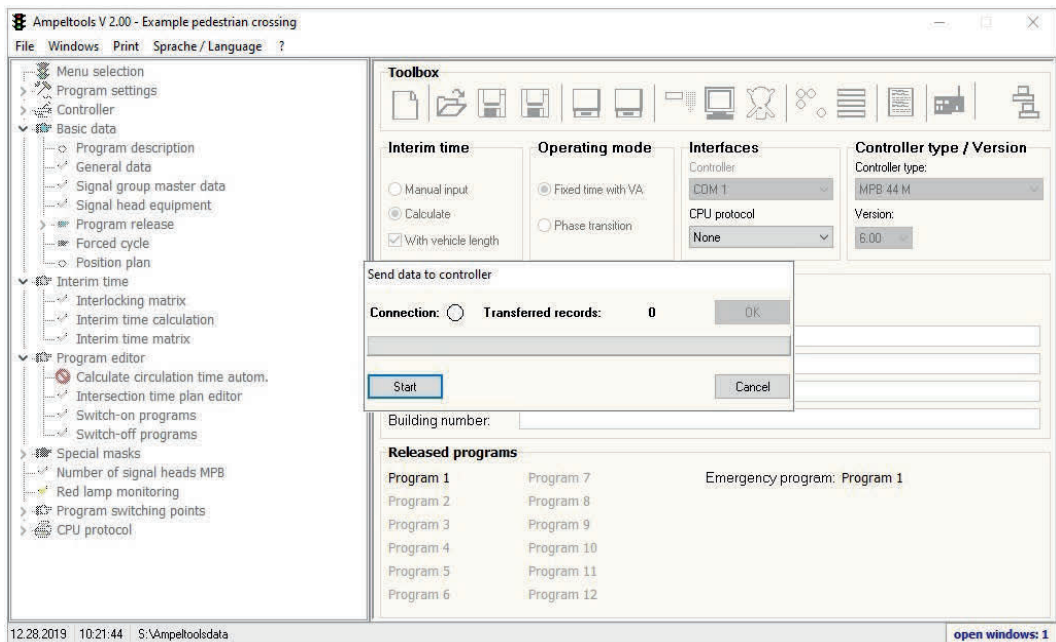

Press **Start** for data transfer to begin.

A progress bar appears while data transfer is active. If you receive an error message instead, please check the connection (controller type, PC lead, COM port, 12 groups interface switched on / correct setting).

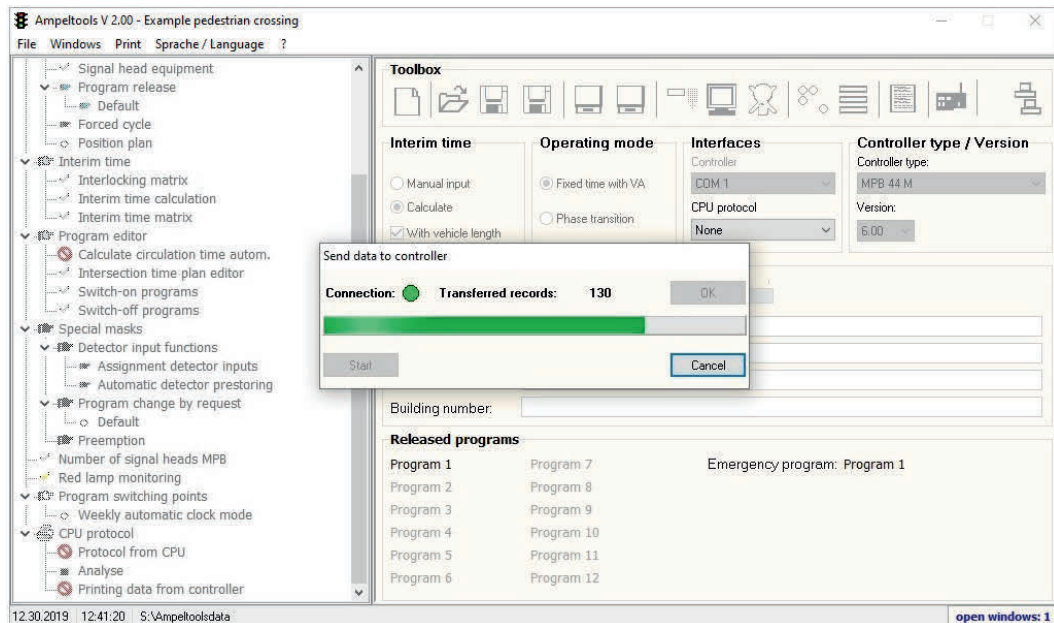

OK is enabled again once data transfer has been completed. Press to close the data transfer window.

See 4.2.5 for a detailed description of the 12 groups interface manual.

Step 22:

Load saved data

Click on **Load data** to load a saved file.

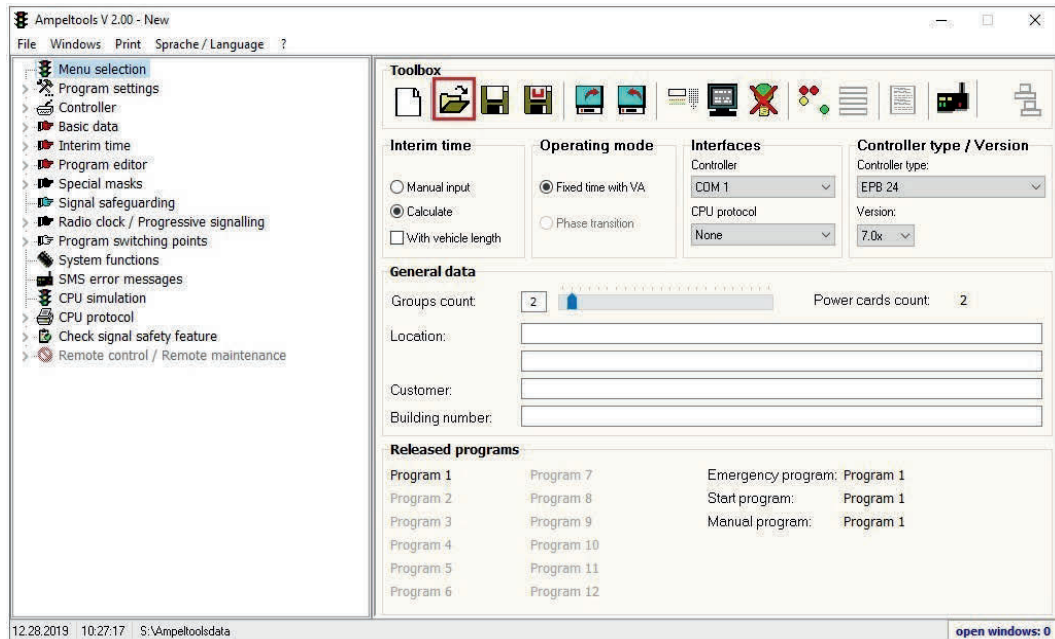

The dialogue box opens and you can select the required file.

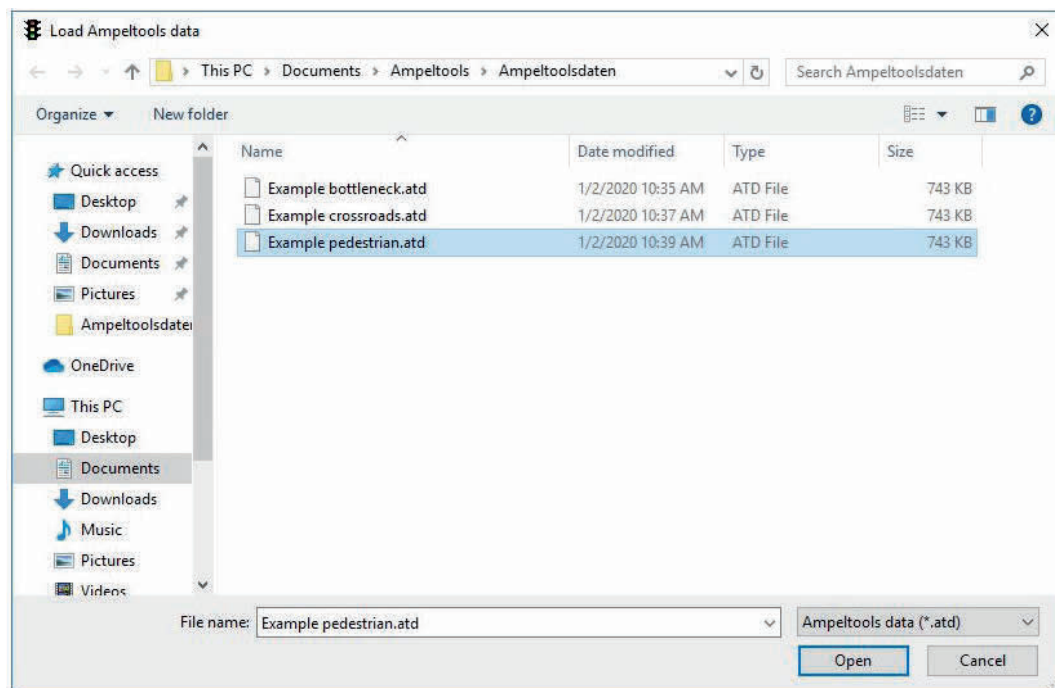

Click on **Open** to start loading the required data; a progress bar appears.

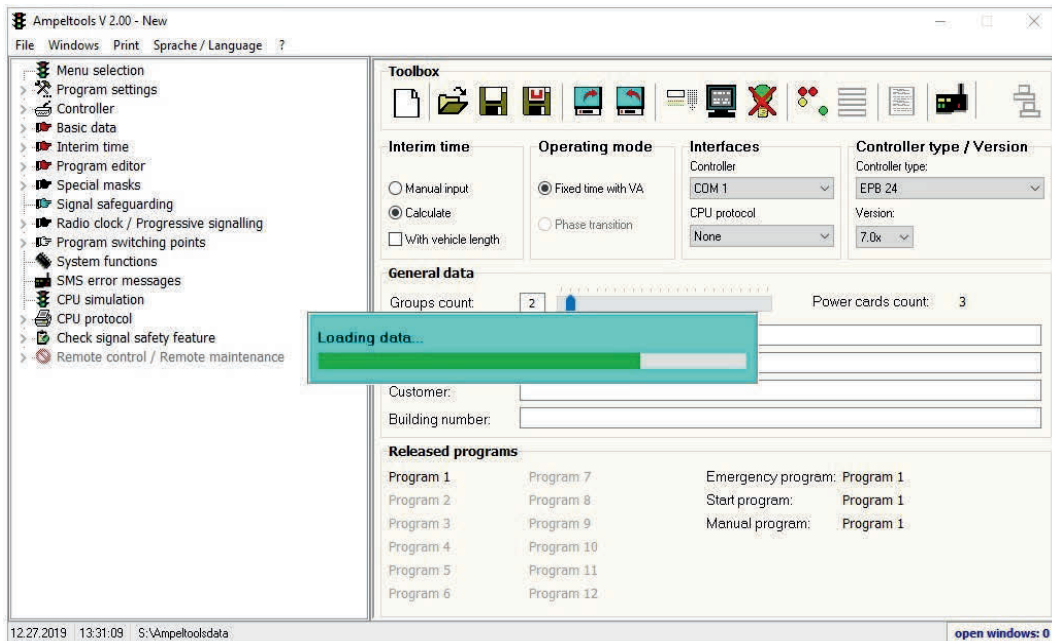

When the data have been loaded, the file name appears in the main window.
The loaded program can now be edited or amended.
See 4.2.2 for a detailed description.

Step 23:
Create map

To create a map, please use a corresponding drawing program.
You can use the integrated drawing module if you only want to create a map that is not to scape.

See 6.1.9 for a detailed description.

Step 24:
Create new program

Select **New** to create a new program.
Please note that it is possible for all currently existing data or changes to be rejected. Please save these data first. You may possibly see a query whether the existing data should now be saved.

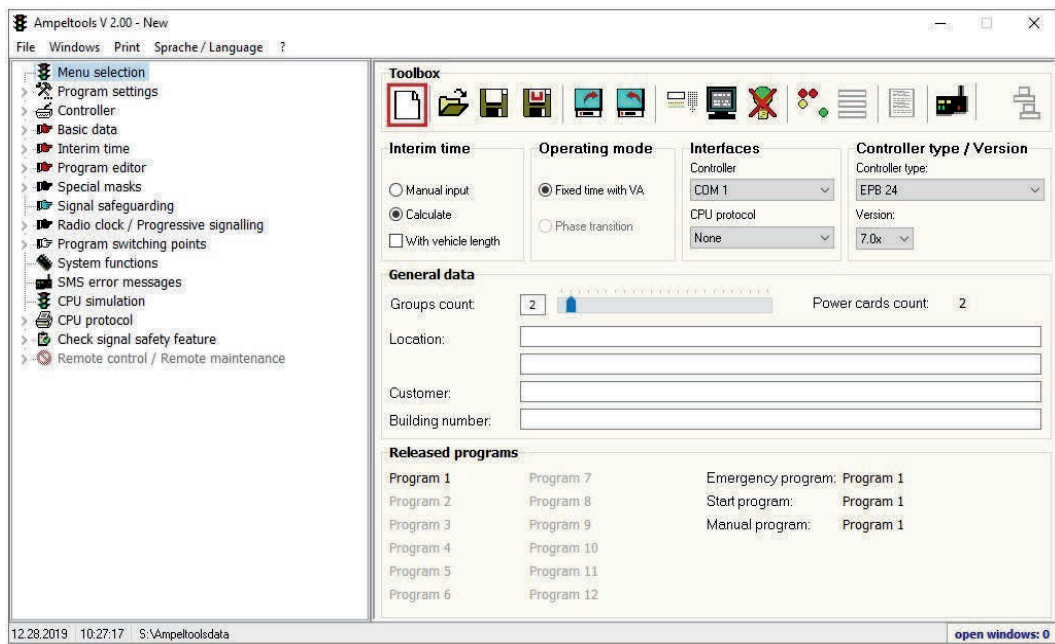

Peter Berghaus GmbH

Herrenhöhe 6 · 51515 Kürten

Telefon +49 2207 9677-0

berghaus-verkehrstechnik.de